

NewTek TriCaster Family

TRICASTER™ - TRICASTER PRO™ - TRICASTER STUDIO™ - TRICASTER BROADCAST™



Table of Contents

TABLE OF CONTENTS	2
1 SOFTWARE LICENSE AND LIMITED WARRANTY	2
2 INTRODUCTION	8
2.1 Meet the Family	8
2.1.1 TriCaster	8
2.1.2 TriCaster PRO	10
2.1.3 TriCaster STUDIO	11
2.1.4 TriCaster BROADCAST	12
2.2 Keeping Tabs (Manual Conventions)	13
3 QUICK START GUIDE	16
3.1 What's included	16
3.1.1 Back Connections	16
3.1.2 Windows Activation	17
3.1.3 Front Connections	18
3.2 Intro to Live Production	18
3.2.1 LIVE Operating Modes	19
3.2.2 The LIVE Production tab	22
3.2.3 Input Setup and Switching	22
3.2.4 External	24
3.2.5 DDR (& Picture)	27
3.2.6 Text and Titles	30
3.2.7 Color Backgrounds	32
3.2.8 LiveMatte	33
3.2.9 Audio	37
3.2.10 Internet Streaming	39
3.3 Capture Media	39

3.4	Edit Media	43
3.4.1	Storyboard.....	44
3.4.2	Timeline.....	45
3.4.3	Controls	46
3.5	Edit Text	50
4	LIVE PRODUCTION	52
4.1	Monitoring	52
4.1.1	Tricaster (3-Camera).....	53
4.1.2	3-Cam ISO Mode (PRO, STUDIO & BROADCAST).....	56
4.1.3	6-Camera Mode (STUDIO, BROADCAST).....	58
4.2	Live Control	60
4.2.1	The Switcher and T-Bar.....	61
4.2.2	The Transition Bank.....	62
4.2.3	Overlay	63
4.3	Setup and Audio Section	66
4.3.1	DDR (and Picture).....	66
4.4	Text	72
4.5	Color Background	75
4.6	Input Setup	76
4.6.1	Input Selection.....	77
4.6.2	Proc Amp	77
4.7	LiveMatte	79
4.8	LiveSet	83
4.8.1	Utilities – MATTE OPTIONS.....	83
4.8.2	Other Utilities.....	84
4.8.3	LiveSet Power!	85
4.8.4	More Liveset	87
4.9	External	88

4.9.1	Using iVGA	88
4.9.2	Using LiveText	92
4.9.3	External Source	92
4.9.4	iVGA Overlay	94
4.9.5	Output to VGA	95
4.9.6	Resolution	95
4.9.7	VGA Keying	95
4.10	Record or Stream	97
4.10.1	Record Options	98
4.10.2	Live Streaming.....	99
4.11	Audio Mixer	101
4.11.1	Basic Audio Controls.....	101
4.11.2	Monitoring and Master Control	103
4.11.3	Audio Simple.....	103
4.11.4	Advanced	103
4.11.5	Audio Setup	104
4.12	Configure Panel (BROADCAST)	105
4.12.1	Video Signal	106
4.12.2	Genlock.....	106
5	CAPTURE MEDIA.....	108
5.1	Capture Details.....	109
5.2	DV Camera Control.....	110
5.3	Captured Files	111
5.3.1	Importing Files and Archiving Data	112
6	EDIT MEDIA	114
6.1	Two Editors in One!.....	114
6.1.1	The Monitor	114
6.1.2	The Media Bin	116

6.2	The Editor – Overview	120
6.2.1	Control Panel	120
6.2.2	Edit Pane View Options	123
6.3	The Storyboard	124
6.3.1	Adding Clips to the Storyboard	124
6.3.2	Trimming Clips	124
6.3.3	Storyboard Ripple.....	126
6.3.4	Inserting a Transition.....	126
6.3.5	Storyboard Play Options.....	127
6.4	The Timeline	128
6.4.1	The Edit Line	129
6.4.2	Adding Clips to the Timeline	129
6.4.3	Inherit.....	130
6.4.4	Zooming and Scrolling	130
6.4.5	Trimming clips.....	131
6.4.6	Timeline Snapping.....	131
6.4.7	Markers	132
6.4.8	Drag Copying.....	134
6.4.9	Timeline Transitions	135
6.4.10	Filters and Fades	138
6.4.11	Titles.....	139
6.4.12	Audio	155
6.4.13	Master Color	156
6.4.14	White Balance	156
6.4.15	Color Correction — RGB/YUV	158
6.5	Tool Shed	159
7	EDIT TEXT	166
7.1	Interface Layout	167
7.2	Project Page Management	167
7.2.1	The Pages Panel	167
7.2.2	Project	169
7.3	The Tool Panel	170

7.3.1	Text and Drawing	170
7.3.2	Alignment	174
7.4	The Motion Panel.....	175
7.4.1	Speed Control	176
7.4.2	End Behavior.....	176
7.5	Control Panel Tabs	176
7.5.1	View.....	177
7.5.2	Text and Drawing	178
7.5.3	The Color Tab.....	181
7.5.4	The Style Tab.....	184
7.5.5	The Filebin	185
7.5.6	The Layers Tab	186
7.6	Options and Keyboard Control	187
8	LIVEMATTE, LIVESET, LIVE ACTION!	188
8.1	LiveMatte.....	188
8.1.1	Practical Staging for LiveMatte	189
8.2	LiveSet	191
8.2.1	Easy as 1-2-3	192
8.2.2	Multi-Cam LiveSet	194
8.2.3	Creating Your Own LiveSets.....	194
9	ADMINISTRATION.....	196
9.1	The Administration Panel.....	196
9.1.1	Reset Configurations	197
9.1.2	Defragment Hard-Drive	198
9.1.3	Check for Add-Ons	198
9.1.4	Software Update.....	198
9.1.5	Technical Support.....	199
9.1.6	Launch TriCaster.....	199
9.1.7	Configure TriCaster	199

9.2	System Restore	200
9.2.1	Limiting User Access.....	201
9.2.2	TriCaster File Extensions.....	201
9.2.3	Default Folders.....	201
10	STREAMING, NETWORKING AND THE INTERNET.....	204
10.1	Streaming Strategies	204
10.1.1	On Demand, or Live?.....	204
10.1.2	Streaming Protocols	206
10.1.3	Streaming Media Providers	208
10.1.4	Other Resources.....	209
10.2	TriCaster Streaming.....	209
10.2.1	Pull Profiles	210
10.2.2	Push Profiles	212
10.3	Production and Capture Considerations	213
10.4	Configuration and Troubleshooting.....	214
10.4.1	Testing your stream.....	214
11	A FEW WORDS ON PERFORMANCE	222
11.1.1	Resource Considerations	222
11.1.2	IMAG and Latency.....	223
12	APPENDIX A —SIGNAL FLOW	226
12.1	TriCaster.....	226
12.2	TriCaster PRO	227
12.3	TriCaster STUDIO.....	228
12.4	TriCaster BROADCAST	229
13	APPENDIX B – KEYBOARD SHORTCUTS.....	230

13.1	Live Production	230
13.1.1	Switcher.....	230
13.1.2	DDR & Picture	231
13.1.3	VGA Output.....	232
13.2	Capture Media	233
13.2.1	Capture.....	233
13.3	Edit Media.....	234
13.3.1	Capture.....	234
13.3.2	Play.....	234
13.3.3	Drag and Drop.....	235
13.3.4	In/Out Points.....	236
13.3.5	Misc.....	237
13.3.6	Timeline Tools.....	237
13.4	Edit Text.....	238
13.5	General	242
13.5.1	Clipboard.....	242
13.5.2	Files/Filebin.....	242
14	INDEX.....	246
15	CREDITS.....	250

1 SOFTWARE LICENSE AND LIMITED WARRANTY

PLEASE READ CAREFULLY BEFORE INSTALLING AND/OR USING THIS SOFTWARE. BY INSTALLING AND/OR USING THIS SOFTWARE, YOU AGREE TO BECOME BOUND BY THE TERMS OF THIS LICENSE. IF YOU DO NOT AGREE TO THE TERMS OF THIS LICENSE, RETURN THIS PACKAGE TO THE PLACE WHERE YOU OBTAINED IT WITHIN 15 DAYS OF PURCHASE FOR A FULL REFUND.

1. Grant of License

The enclosed computer program(s) (the "Software") is licensed, not sold, to you by NewTek, Inc. (NEWTEK) for use only under the terms of this License, and NEWTEK reserves any rights not expressly granted to you. You own the disk(s) on which the Software is recorded or fixed, but the Software and all copyright rights therein, foreign and domestic, is owned by NEWTEK or its suppliers and is protected by United States copyright laws and international treaty provisions.

The copyright restrictions of this license extend to any further updates, software patches, or bug fixes made available to you by NEWTEK, whether distributed by floppy disc, CD ROM, DVD ROM or in an electronic format via BBS, ftp, email, etc.

This License allows you to use one copy of the Software on a single computer at a time. To "use" the Software means that the Software is either loaded in the temporary memory (i.e., RAM) of a computer, or installed on the permanent memory of a computer (i.e., hard disk, CD ROM, DVD ROM, etc.).

You may use at one time as many copies of the Software as you have licenses for. You may install the Software on a common storage device shared by multiple computers, provided that if you have more computers having access to the common storage device than the number of licensed copies of the Software, you must have some software mechanism which locks out any concurrent user in excess of the number of licensed copies of the Software (an additional license is not needed for the one copy of Software stored on the common storage device accessed by multiple computers).

You may make one copy of the Software in machine readable form solely for backup purposes. The Software is protected by copyright law. As an express condition of this License, you must reproduce on the backup copy the NEWTEK copyright notice in the following format "(c) 1990 - 2008 NEWTEK"

You may permanently transfer all your rights under this License to another party by providing such party all copies of the Software licensed under this License together with a copy of this License and all written materials accompanying the Software, provided that the other party reads and agrees to accept the terms and conditions of this License.

2. Restrictions

The Software contains trade secrets in its human perceivable form and, to protect them, YOU MAY NOT REVERSE ENGINEER, DECOMPILE, DISASSEMBLE, OTHERWISE REDUCE THE SOFTWARE TO ANY HUMAN PERCEIVABLE FORM. YOU MAY NOT MODIFY, ADAPT, TRANSLATE, RENT, LEASE, LOAN, RESELL FOR PROFIT, OR CREATE ANY MODIFICATIONS OR OTHER DERIVATIVE WORKS BASED UPON THE SOFTWARE OR ANY PART THEREOF.

3. Termination

This License is effective until terminated. This License will terminate immediately without notice from NEWTEK or judicial resolution if you fail to comply with any provision of this License. Upon such termination you must destroy the Software, all accompanying written materials and all copies thereof. You may also terminate this License at any time by destroying the Software, all accompanying written materials and all copies thereof.

4. Export Law Assurances

You agree that neither the Software nor any direct product thereof is being or will be shipped, transferred or re-exported, directly or indirectly, into any country prohibited by the United States Export Administration Act and the regulations thereunder or will be used for any purpose prohibited by the Act.

5. Limited Warranty and Disclaimer, Limitation of Remedies and Damages.

YOU ACKNOWLEDGE THAT THE SOFTWARE MAY NOT SATISFY ALL YOUR REQUIREMENTS OR BE FREE FROM DEFECTS. NEWTEK WARRANTS THE MEDIA ON WHICH THE SOFTWARE IS RECORDED TO BE FREE FROM DEFECTS IN MATERIALS AND WORKMANSHIP UNDER NORMAL USE FOR 90 DAYS FROM PURCHASE, BUT THE SOFTWARE AND ACCOMPANYING WRITTEN MATERIALS ARE LICENSED "AS IS." ALL IMPLIED WARRANTIES AND CONDITIONS (INCLUDING ANY IMPLIED WARRANTY OF MERCHANTABILITY OR FITNESS FOR A PARTICULAR PURPOSE) ARE DISCLAIMED. YOUR EXCLUSIVE REMEDY FOR BREACH OF WARRANTY WILL BE THE REPLACEMENT OF THE MEDIA OR REFUND OF THE PURCHASE PRICE. IN NO EVENT WILL NEWTEK OR ITS DEVELOPERS, DIRECTORS, OFFICERS, EMPLOYEES OR AFFILIATES BE LIABLE TO YOU FOR ANY CONSEQUENTIAL, INCIDENTAL OR INDIRECT DAMAGES (INCLUDING DAMAGES FOR LOSS OF BUSINESS PROFITS, BUSINESS INTERRUPTION, LOSS OF BUSINESS INFORMATION, AND THE LIKE), WHETHER FORESEEABLE OR UNFORESEEABLE, ARISING OUT OF THE USE OR INABILITY TO USE THE SOFTWARE OR ACCOMPANYING WRITTEN MATERIALS, REGARDLESS OF THE BASIS OF THE CLAIM AND EVEN IF NEWTEK OR AN AUTHORIZED NEWTEK REPRESENTATIVE HAS BEEN ADVISED OF THE POSSIBILITY OF SUCH DAMAGES.

The above limitations will not apply in case of personal injury only where and to the extent that applicable law requires such liability. Because some jurisdictions do not allow the exclusion or limitation of implied warranties or liability for consequential or incidental damages, the above limitations may not apply to you.

6. General

This License will be construed under the laws of the State of Texas, except for that body of law dealing with conflicts of law. If any provision of this License shall be held by a court of competent jurisdiction to be contrary to law, that provision will be enforced to the maximum extent permissible and the remaining provisions of this License will remain in full force and effect.

7. Trademarks

TriCaster, TriCaster PRO, TriCaster Pro FX, TriCaster STUDIO, TriCaster PRO, SpeedEDIT, LiveText, LiveControl, 3Play, VT, VT[3], VT[4], VT[5], Video Toaster, Toaster, Inspire 3D, 3D Arsenal and Aura are trademarks of NEWTEK. LightWave and LightWave 3D are registered trademarks of NEWTEK. All other brand names, product names, or trademarks belong to their respective holders.

8. MPEG-2, MPEG-4

Use of this product commercially, including the distribution of content media, may require additional licenses from MPEG sources, depending on your usage.

ANY USE OF THIS PRODUCT OTHER THAN CONSUMER PERSONAL USE IN ANY MANNER THAT COMPLIES WITH THE MPEG-2 STANDARD FOR ENCODING VIDEO INFORMATION FOR PACKAGED MEDIA IS EXPRESSLY PROHIBITED WITHOUT A LICENSE UNDER APPLICABLE PATENTS IN THE MPEG-2 PATENT PORTFOLIO, WHICH LICENSE IS AVAILABLE FROM MPEG LA, L.L.C., 250 STEELE STREET, SUITE 300, DENVER, COLORADO 80206.

THIS PRODUCT IS LICENSED UNDER THE MPEG-4 VISUAL PATENT PORTFOLIO LICENSE FOR THE PERSONAL AND NON-COMMERCIAL USE OF A CONSUMER FOR (i) ENCODING VIDEO IN COMPLIANCE WITH THE MPEG-4 VISUAL STANDARD ("MPEG-4 VIDEO") AND/OR (ii) DECODING MPEG-4 VIDEO THAT WAS ENCODED BY A CONSUMER ENGAGED IN A PERSONAL AND NON-COMMERCIAL ACTIVITY AND/OR WAS OBTAINED FROM A VIDEO PROVIDER LICENSED BY MPEG LA TO PROVIDE MPEG-4 VIDEO. NO LICENSE IS GRANTED OR SHALL BE IMPLIED FOR ANY OTHER USE. ADDITIONAL INFORMATION INCLUDING THAT RELATING TO PROMOTIONAL, INTERNAL AND COMMERCIAL USES AND LICENSING MAY BE OBTAINED FROM MPEG LA, LLC. SEE [HTTP://WWW.MPEGLA.COM](http://www.mpegla.com).

9. Other MPEG – No warranty

Your use of this product to distribute CD's, streaming video, or other media, or certain other commercial uses, may require additional licensing from other appropriate MPEG licensing sources, and no warranty is made otherwise.

10. US Government Restricted Provision

If this Software was acquired by or on behalf of a unit or agency of the United States Government this provision applies. This Software:

- (a) Was developed at private expense, and no part of it was developed with government funds,
- (b) Is a trade secret of NEWTEK for all purposes of the Freedom of Information Act,

(c) Is "commercial computer software" subject to limited utilization as provided in the contract between the vendor and the government entity, and

(d) In all respects is proprietary data belonging solely to NEWTEK.

For units of the Department of Defense (DoD), this Software is sold only with "Restricted Rights" as that term is defined in the DoD Supplement to the Federal Acquisition Regulations, 52.227-7013 (c) (1) (ii).

Use, duplication or disclosure is subject to restrictions as set forth in subdivision (c) (l) (ii) of the Rights in Technical Data and Computer Software clause at 52.227-7013. Manufacturer: NEWTEK, 5131 Beckwith Boulevard, San Antonio, TX 78249.

If this Software was acquired under a GSA Schedule, the US Government has agreed to refrain from changing or removing any insignia or lettering from the software or the accompanying written materials that are provided or from producing copies of manuals or disks (except one copy for backup purposes) and:

(e) Title to and ownership of this Software and documentation and any reproductions thereof shall remain with NEWTEK,

(f) Use of this Software and documentation shall be limited to the facility for which it is required, and,

(g) If use of the Software is discontinued to the installation specified in the purchase/delivery order and the US Government desires to use it at another location, it may do so by giving prior written notice to NEWTEK, specifying the type of computer and new location site. US Governmental personnel using this Software, other than under a DoD contract or GSA Schedule, are hereby on notice that use of this Software is subject to restrictions which are the same as or similar to those specified.

NewTek Inc. Limited Hardware Warranty

This warranty covers only the hardware portion of the TriCaster Product delivered ("Product") and extends to the original purchaser only. Software is licensed to you, not sold, under a separate license agreement, above, that has its own warranty terms.

NewTek warrants that for a period of 1 year from the date of your original purchase of our computer/video product (hardware), it shall be free from defects in material and workmanship. If a defect is determined to be covered by this warranty as determined by NewTek, NewTek will correct it, and may do so using new or remanufactured components.

NewTek's Liability and Limitations. NewTek's obligations are only as expressly stated herein. NewTek is not liable for loss or damage for inconvenience or interruption of service, loss of business, data or anticipatory profits, or consequential, incidental or punitive damages resulting from the use (or operation) of any of the products purchase

by you. NewTek's liability is limited solely to the repair or replacement of the defective product. NewTek is under no obligation or responsibility to enhance or update the product. This warranty does not cover damage or malfunctions resulting from improper handling, accident, misuse, abuse, neglect, electrical surges, failure of electrical power, use with other products not manufactured or approved by NewTek, installation or removal charges or damages, damage while in transit for repair, repair attempted by any unauthorized person, or any other reason not due to defects in materials and workmanship. This warranty is also void if any applicable serial number has been altered, defaced, or removed.

The hardware and software in this product are designed to work in conjunction with each other. Any termination of the Software License, including use of the software, or any portion of the software, not in conjunction with the hardware provided in the same computer, will void all warranties and any technical support service otherwise available.

To Obtain Warranty Service. To obtain free repair under this warranty, contact NewTek Technical Support for confirmation, receive a Returned Materials Authorization (RMA), and deliver the product along with proof of ownership (such as the original invoice, or a photocopy) to NewTek. You will be responsible for any costs associated with the delivery to and from our service center.

Other Legal Disclosures. The above warranty is exclusive and in lieu of all other warranties, expresses or implied (other than those warranties implied by state law). All applicable state statutory implied warranties, including, but not limited to implied warranties of merchantability or fitness for a particular purpose, shall be limited to a period of 1 year from the date of your original purchase. No warranties, either express or implied, will apply after this period.

Because so many states have different laws that are ever-changing, and because we have no desire to conflict with these laws, then any term of this warranty that is prohibited by applicable law shall not apply. Some states do not allow limitations on how long an implied warranty lasts or the exclusion of warranties or of incidental or consequential damages, so the above limitations or exclusions may not apply to you. This warranty gives you specific legal rights, and you may have other rights which vary from state to state.

2 INTRODUCTION

Welcome to the world of portable live production! With any member of the NewTek TriCaster lineup, you can produce live video programs from diverse sources - including multiple cameras, recorded digital video, PowerPoint, live web pages, high-resolution imagery and much more! Better still, your presentation can be simultaneously distributed to projector, video and the Internet.

Creating live network style television can be very costly, normally requiring very expensive equipment and a large crew. TriCaster changes all that. In one small, lightweight, portable system (small enough to fit in a backpack) you have all the tools required to create, broadcast, web stream and project your show. Select models even include live virtual sets (LiveSet™) to give you full 'network-class' production capabilities!

TriCaster is the standard in "portable live production" because it is the most complete, reliable and efficient system available for live production and web streaming. TriCaster's small footprint makes it possible to broadcast from literally anywhere and only requires one person to make it work. No matter what your live broadcast goals are, there is a TriCaster perfect for you.

2.1 MEET THE FAMILY

The TriCaster family tree presently has four branches – TriCaster, TriCaster PRO, TriCaster STUDIO, and TriCaster BROADCAST. As in most families, many characteristics are common, while others serve to differentiate the different members.

Let's take a quick look at the family album, and then we'll explain how this manual is organized.

2.1.1 TRICASTER



TriCaster is a portable production system. At just under 10-pounds and the size of a shoe box you can take TriCaster anywhere. Plug it in, hook up 3 camcorders, and live mix your camera sources with video from the Digital Disk Recorder (DDR, or 'virtual VCR') using cut and fade transitions or any one of the 200+ video effects that come with the system. Your production can be complete and polished with opening titles, closing credits and graphics to identify your participants and locations.

- Quickly and flexibly connect and switch between three live composite or S-Video cameras
- Camera Auto-Calibration

- Support for standard 4:3 or widescreen 16:9 formats
- RCA video connectors for hook-up to any camera
- Audio connectors for professional audio mixing
- Record full-screen video using a multi-platform compatible format, or archive your Internet stream
- Enjoy the flexibility of simultaneous output to broadcast, projector and live web stream for both in-house and remote audiences
- LiveMatte™ realtime keying technology
- Template-based titling system makes creating powerful graphics and titles quick and easy
- With NewTek's iVGA™, any PC or Mac on the same network as TriCaster can be added as an input for your TriCaster live production
- Full integrated character generator; create custom titles, motion graphics, scrolls and crawls
- 200+ different effects allow you to transition from one camera or source to another with style
- Integrated DDR allows you to playback pre-recorded video in your live presentation
- Built-in audio mixer allows you to effectively blend microphones, musical score and other sound elements
- Picture player allows you to include photos and still images in your production
- Simultaneously record while archiving your web stream
- Windows Media™ (incl. VC-1) streaming
- Built-in video editing lets you prepare video segments in advance for replay during your live production – now includes support working with HD video files in SD edit projects
- Import and export file format support extended to include MPEG and QuickTime for greater versatility in program delivery
- XGA, SXGA, QSXGA and higher resolution Projector support

Video Input	3 Y/C 3 Composite (RCA)	Audio Input	2 Unbalanced Mic Inputs (phone) 1 Stereo Line In (RCA)
Video Output	1 Y/C 1 Composite (RCA)	Audio Output	1 Unbalanced Line Out (Phone) Stereo Headphone Out
Video Ingest	1 x 4-pin IEEE 1394 1 x 6-pin IEEE 1394	iVGA™ Input	1 Ethernet Network Connection Supports 1 iVGA source
Video Preview Monitoring	3 ISO monitors	DDR Playback (with alpha)	1 Video DDR 1 Picture (Still Store)

2.1.2 TRICASTER PRO



TriCaster PRO provides professional flexibility, adding the ability to mix component (YUV), composite and S-Video camera sources, balanced XLR audio connectors, using professional audio and video connectors, adding increased storage and more.

LiveSet virtual set technology allows you to achieve the look of a sophisticated studio setting within a very small studio space without the need for external equipment. To the many powerful base TriCaster features listed previously, TriCaster PRO adds the following:

- Professional class component (YUV) video input/output
- Professional BNC video connectors provide increased durability and reliability for your camera hook-ups (connect Y/C sources using either 4-pin or dual BNC connectors)
- Balanced XLR or phone jack audio connectors for professional audio mixing
- Over 20 hours of video storage
- Large Preview monitor (in addition to 3 dedicated ISO monitors)
- DDR (with alpha) can be assigned to the DSK (Downstream Keyer) for animated overlays
- Picture player has advanced playback controls like DDR (including Cue)
- Expanded iVGA™ support - up to three Mac and PC's on the same network with your TriCaster can be selected as inputs for your TriCaster live production
- Effects Row on Switcher
- Record Effects Source or Live Program
- Independent LiveMatte™ keyer settings for each switcher source
- LiveSet virtual set technology
- Lock titles or graphics to designated sources
- Flash™ streaming
- Image Enhancement controls for VGA output (to projector)

Video Input	3 Y/C 3 Composite (BNC) 3 Component (BNC)	Audio Input	2 Balanced Mic/Line Inputs (XLR or Phone) 1 Stereo Line In (RCA)
Video Output	1 Y/C 1 Composite (BNC)1	Audio Output	2 Balanced Line Out (Phone) 1 Stereo Headphone Out

	Component (BNC)		
Video Ingest	1 x 4-pin IEEE 1394 1 x 6-pin IEEE 1394	Pro Audio Options	Mic/Line Impedance Switchable Phantom Power
Video Preview Monitoring	3 ISO monitors	iVGA™ Input	1 Ethernet Network Connection Supports 3 available iVGA sources
Signal Monitoring	Waveform Monitor Vectorscope	DDR Playback (with alpha)	1 Video DDR 1 Picture (Still Store)
Recording	Record Effects or Live Output		

2.1.3 TRICASTER STUDIO



TriCaster STUDIO is a live production *workhorse*. Switch between six cameras, use LiveMatte™ real-time chromakeying, live titling, audio mixing, live video streaming and more. In TriCaster STUDIO you have all of the power of a broadcast control room in one simple to use broadcast appliance.

As with TriCaster PRO, the LiveSet™ virtual set technology in TriCaster STUDIO allows you to achieve the look of a sophisticated studio setting within a very small studio space without the need for external equipment.

Here's how TriCaster STUDIO extends the power of the TriCaster family:

- Three additional component, composite or S-Video cameras (for a total of six) permit full camera coverage of events
- A second cue-able DDR (with alpha channel support) extends and eases integrating of clips and graphics into your live productions
- Assign either DDR to downstream key for scrolls, crawls and motion lower-thirds
- Dual operating modes: choose six-camera mode sharing a larger preview monitor, or three camera mode, each with its own dedicated preview monitor
- Four balanced XLR or phone jack audio connectors for professional audio mixing

Video Input	6 Y/C 6 Composite (BNC) 6 Component (BNC)	Audio Input	4 Balanced Mic/Line Inputs (XLR or phone)
Video Output	2 Y/C (mini-DIN or BNC) 2 Composite (BNC) 2 Component (BNC)	Audio Output	2 Balanced Line Outs (phone) 2 Unbalanced Line Outs (RCA) 1 Stereo Headphone Out
Video Ingest	1 x 4-pin IEEE 1394 1 x 6-pin IEEE 1394	Pro Audio Options	Mic/Line Impedance Switchable Phantom Power
Video Preview Monitoring	3 ISO monitors OR Single large preview in 6 cam mode	iVGA™ Input	1 Ethernet Network Connection Supports 3 available iVGA sources
Signal Monitoring	Waveform Monitor Vectorscope	DDR Playback (with alpha)	2 Video DDRs
Tally	6 Tally Light Connections	Recording	Record Effects or Live Output

2.1.4 TRICASTER BROADCAST



TriCaster BROADCAST is a live production *workhorse*. Switch between six cameras, use LiveMatte™ real-time chromakeying, live titling, audio mixing, live video streaming and more. In TriCaster BROADCAST you have all of the power of a network control room in one simple to use broadcast appliance.

- State of the art SDI (Serial Digital Interface) video input/output
- SDI (capture) and AES audio

- Advanced Preferences panel

Video Input	6 Y/C (BNC) 6 Composite (BNC) 6 Component (BNC) 6 SDI (BNC)	Audio Input	4 Balanced Mic/Line (XLR or phone) 1 AES/EBU Digital Audio Embedded Audio (SDI)
Video Output (Program)	1 Y/C (BNC) 1 Composite (BNC) 1 Component (BNC) 1 SDI (BNC)	Audio Output	2 Balanced Line Outs (phone) 2 Unbalanced Line Outs (RCA) 1 Stereo Headphone Out 1 AES/EBU Digital Audio Embedded Audio (SDI)
Video Output (Preview)	1 Y/C (BNC) 1 Composite (BNC) 1 Component (BNC) 1 SDI (BNC)	Tally	6 Tally Light Connections
Video Ingest	1 x 4-pin IEEE 1394 1 x 6-pin IEEE 1394	Pro Audio Options	Mic/Line Impedance Switchable Phantom Power
Video Preview Monitoring	3 ISO monitors – OR – Single large preview in 6 cam mode	iVGA™ Input	1 Ethernet Network Connection Supports 3 available iVGA sources
Signal Monitoring	Waveform Monitor Vectorscope	DDR Playback (with alpha)	2 Video DDRs
Recording	Record Effects or Live Output		

2.2 KEEPING TABS (MANUAL CONVENTIONS)

The various TriCaster family members have many common attributes, but as we go along we will encounter differences of course. One or more models may provide an extra feature that extends beyond the point under immediate discussion; or the display shown along with the text may vary slightly from the model you have.

We'll provide assistance along the way, so you'll know which features and functions are relevant to your own TriCaster and production environment:

Sidebar: At times, you may notice a nearby sidebar highlighting distinctions briefly.

Captions: Image captions may identify differences between models (in some cases - when differences don't really bear on the point illustrated - a single representative screenshot may be used.)

Cross References: When a more in-depth explanation for a feature is provided elsewhere in the manual, we'll add a cross reference to the relevant section. In some cases, major features (such as LiveSet™) warrant entire chapters of their own, and we'll draw your attention to that too.



LET'S JUMP IN NOW - FIRST GETTING YOU CONNECTED, AND THEN EXPLORING THE MOST IMPORTANT FEATURES OF YOUR NEW TRICASTER!

3 QUICK START GUIDE

This chapter will help you quickly understand important features common to all TriCaster models: LIVE Production, Capture Media, Edit Media, Edit Text, Internet Streaming, importing video and pictures. Many features and controls are explained in much more depth in the subsequent chapters, but this Quick Start section will have you producing your own live broadcast in no time. Let's get started!



Figure 1

At upper-right on TriCaster's screen is a digital clock. This is great for timing Live Production or Capture sessions, tracking 'billable hours', or just impressing your friends with your mastery of time. Mainly though, TriCaster is just so engaging, creative and productive that you'll lose track of time! Come up for air once in awhile, walk the dog, eat and be merry!

3.1 WHAT'S INCLUDED

The following components are included with your TriCaster: Manual, Registration Card, A/C Power cord, Keyboard, Mouse, DVI-to-DB15 (VGA) adapter, network crossover cable, S-Video Cable, TriCaster Utilities for PC Network Sharing and Content Sharing CD.

TriCaster PRO, STUDIO, and BROADCAST models also include BNC to Composite adapters (3 for PRO, 6 for STUDIO and BROADCAST). TriCaster BROADCAST (only) includes a DVI-to-HDMI Cable.

(NewTek offers an optional hardware control surface (LiveControl) and other related peripherals and software. See the NewTek website (<http://www.newtek.com>) for more information.)

3.1.1 BACK CONNECTIONS

Let's begin by removing TriCaster from the box, and connecting the supplied keyboard and mouse to your own monitor / projector.

- Write down the 25-digit Windows product key on the bottom of TriCaster. On first power-up, as we'll need to enter that next.
- Connect one end of the supplied power cable to an outlet, and plug into TriCaster's power supply.
- Connect the keyboard and mouse.
- Connect your computer monitor to the DB15 VGA connector.
 - Connect a projector to the DVI-I digital interface before powering up (optional.)
- Connect the local area network (LAN) RJ-45 connector. (To hook up a computer or laptop directly to the TriCaster, make sure to use a special *crossover type* network cable.) At this point, your TriCaster is ready for operation! You may now activate it, by pressing the large power button on its face to initialize the system.

3.1.2 WINDOWS ACTIVATION

(Your dealer may have performed this operation for you as part of his pre-delivery service.)

When you see the 'Welcome to Windows' screen, click Next at lower right, choose your time zone, accept the license agreement, enter your 25-digit key, decline automatic updates by clicking "not right now" and give your TriCaster a distinct computer name for networking.

You can either authorize your Windows installation by network or telephone. The Internet method is fastest by clicking Obtain IP and DNS automatically.

Agree to activate Windows. This activation is permanent, and you won't see these screens again. Registration with Microsoft is optional.

Lastly, you need to assign a name to the administrator account. You may type your name, company, or TriCaster. Click Finish, and you system will re-start.

After restarting and accepting NewTek's TriCaster user agreement, the interface will load automatically.



TriCaster PRO, STUDIO and BROADCAST support both balanced and unbalanced inputs, in either 1/4 inch or XLR.

3.1.3 FRONT CONNECTIONS

TriCaster has full audio support for your presentation. Plug in the presenter's microphone into one of the 1/4-inch phono Mic inputs on the front. (Depending on your model and type of microphone or cable, this may require an adapter.)

It is recommended that you use high-quality shielded cables to minimize hum or noise on the microphone input. If you need to manage audio from an external audio mixer, connect it to the Line In connections.

Connect several cameras to the front of your TriCaster, using suitable connectors for the type of camera. (Please refer to your camera operations manual on either component, composite or S-Video output.)

To send your video output to an external video tape recorder or DVD recorder, connect the appropriate video *outputs* to the deck or DVD device.

If your audio needs to be distributed, you can send a line-level stereo signal from the front connectors to an outboard audio mixer. To monitor audio during the presentation, plug your headphones into the headphone jack.

Congratulations! In just a few minutes, you have powered TriCaster and are now ready for live production, Internet streaming or video editing. Please remember to go to www.newtek.com and register your TriCaster to download any available bonus content and be notified of new features.

3.2 INTRO TO LIVE PRODUCTION

Consider the TriCaster your 'multi-dimensional nexus' in one compact and easily portable case. Seamlessly blend multiple live cameras, audio, digital video, images and titles -- stream your program on the Internet, video monitors, computer screens, projection devices, or all of the foregoing at once! The following will help acquaint you with Live Production mode.



Figure 2 – TriCaster STUDIO

3.2.1 LIVE OPERATING MODES



TriCaster STUDIO and BROADCAST models (only) provide two optional configurations for live production. (TriCaster and TriCaster PRO have fairly similar 3-camera layouts, discussed later.)

According to your personal need or preference, you can choose either **3-Camera** or **6-Camera** mode. These models show an added feature on the TriCaster **Administration** desktop shown at right.

A number of useful options and utilities are located here for convenient access. At lower right in this panel is the large rectangular primary configuration link.

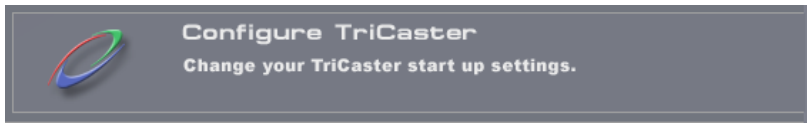
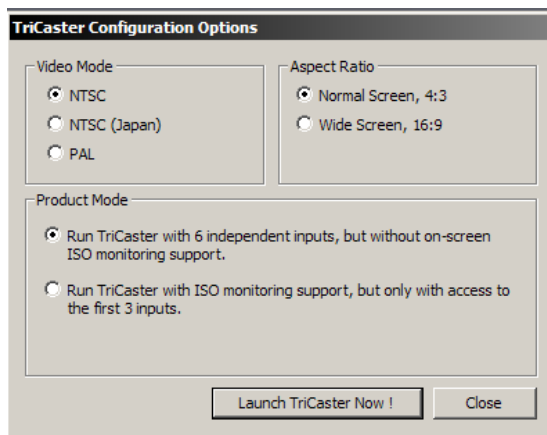

Figure 3

Click this to open the **TriCaster Configuration Options** dialog shown in Figure 4.



Your selections determine the configuration your TriCaster adopts the next time you launch it (using the nearby **Relaunch TriCaster** link on the Administration desktop.)

The upper section of the panel allows you to choose between 4:3 and 16:9 image aspect ratios (selected models may offer two video standard options, NTSC or PAL.) Just beneath this you will see the Mode section.

Figure 4 – TriCaster STUDIO, International version

Your options here are as follows:

3.2.1.1 6-CAMERA MODE

In the 6-Camera mode, all six analog video input connections located on the front panel of the TriCaster STUDIO or BROADCAST system are active and available for use. In this configuration, the upper left-hand third of the LIVE Output screen is occupied by a quad display showing the video sources assigned to a DDR, an External source, and a full-time Waveform Vectorscope.



Figure 5

To the right, large LIVE Output and Preview monitors show the video sources currently assigned on the Switcher's Live and Preview rows. You can sample the video feed from any of the six inputs by selecting them one at a time on the Preview row. However, if you do not need to use more than 3 live video sources, you may find the 3-Camera mode very useful!

3.2.1.2 3-CAMERA MODE

In this mode, only the first three of the TriCaster's analog video Inputs are active. This option is ideal for the common 'three camera' studio setup, and provides one unique advantage.



Figure 6

Each of the three inputs is *permanently* assigned to a small ISO display in the monitoring section of the LIVE Production screen. As seen above, each of the first three monitors in the upper row consistently shows its respective source.

This option is great for portability, relieving you of the bulk (and expense) of using physical monitors to give independent ISO views. (If full-time monitoring of more than three sources is vital, an external monitoring solution will be required.)

NOTE: In this configuration, the optional Waveform/Vectorscope displays in the LIVE Production monitoring section are transplanted to a drop-down menu beneath the large Preview monitor.

A further benefit -- as discussed later (Section 4.1.2.1), in 3-Camera mode the ISO monitors are interactive, allowing you to live switch with greater confidence.

3.2.2 THE LIVE PRODUCTION TAB



Figure 7

The LIVE Production panel has its own tab at the top of the screen. Thea/v stream that you designate as Live in this panel (by clicking its button in the Live row of the Switcher) is TriCaster's output.

It supplies the program sent to any of the output systems mentioned above.

3.2.3 INPUT SETUP AND SWITCHING

1. Connect a camera to **Input 1** on TriCaster's front panel, using the appropriately labeled connector(s) for your camera and cable type

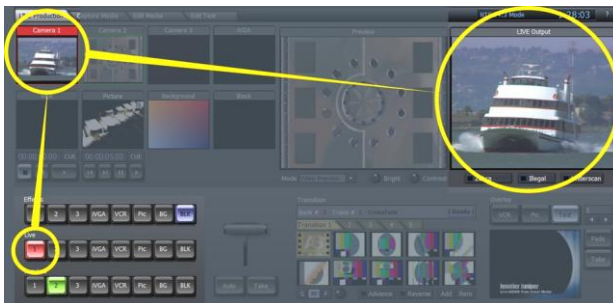

Figure 8 - (6-Camera mode depicted,)

TriCaster models vary, so you may have several or all of the following connection types available:

- ❖ Composite
- ❖ S-Video
- ❖ Component
- ❖ SDI

- Click the **Input Setup** tab, and make sure that the desired input **Type** is selected for your camera type (a blue LED in the interface illuminates to confirm your choice.)

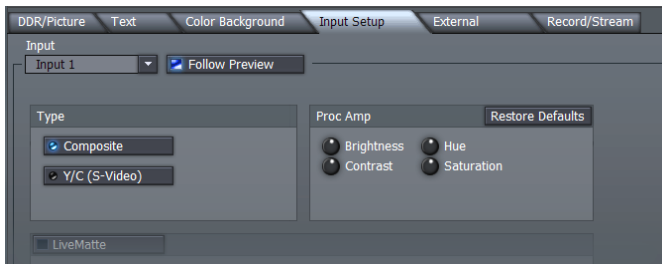

Figure 9 - (Input Setup: TriCaster)



Figure 10 – Input Setup (TriCaster PRO, STUDIO, BROADCAST depicted)

- Make **Input 1** live, by clicking on the **Switcher** button labeled '1' on the second row - **Live**. The button turns red, and the video source appears on the **LIVE Output** monitor. This indicates it is available to connected video display devices and/or the Internet, and optionally for recording to disk, too.



Figure 11 - (Switcher Effects row on selected models only)

- Click the down-triangle beside the **Input** field, select **Input 2**, setting up a second video source assigned to this position (you can use another camera or a VCR or DVD player as the source.)

Left click Input 2 on the **Preview** row.

5. Click **Auto**, and you will see Input 1 fade out (over one second) and be replaced with Input 2. Click **Take** instead if you want the change to occur instantly.

*Note: you can manually control **the transition**, too, by grabbing the T-bar with the left mouse button and dragging it downward.*



Figure 12

You should already have several **Transitions** loaded. You can activate a transition (switching from the source on the Live row to the one in the Preview row) in several ways: double-click the transition in the Transitions pane; click on the transition to select it and then click the Auto button, or simply tap the keyboard Space bar.

3.2.4 EXTERNAL



Figure 13

For a presenter to add **PowerPoint**, web pages, and other content from the display of different computer system, or text or graphics from NewTek's LiveText™ - running on another computer on the network, click the **External** tab.

3.2.4.1 IVGA CLIENTS

1. For a Microsoft Windows® client, copy the **iVGA** program from the TriCaster iVGA folder (inside C:\TriCaster) to the sending computer.

For OS X client systems, copy the file iVGA.dmg.zip file from the same folder to the Mac. Unzip it by double-clicking it; mount the disk image (.dmg file) in the same manner, then drag the iVGA program icon into Applications.

(See Section 4.9.1, Using iVGA for more detail)

2. Connect your TriCaster to the client computer via the local network. (For computer-to-computer connections, use the supplied crossover cable to connect directly to TriCaster.)

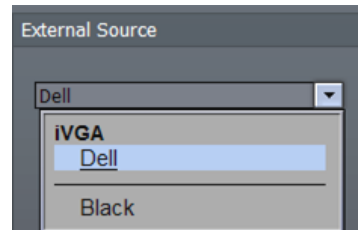

Figure 14 - TriCaster iVGA

3. Double-click the iVGA icon on the second computer.

After agreeing to the NewTek license, and a moment or two for the network connection to be established, the name of the remote computer is added (along with “Black” and any other networked systems with iVGA running on them) in the iVGA client list of the **External Source** menu of your TriCaster.

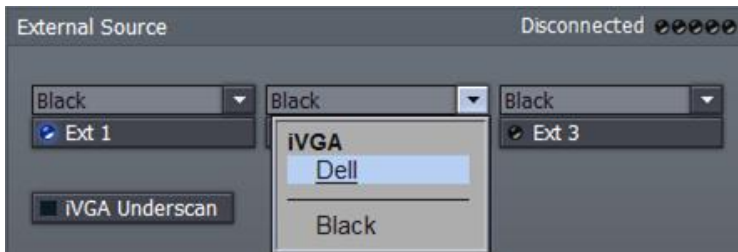

Figure 15 - STUDIO, PRO and PRO offer triple External Source selectors

When in operation, iVGA places a red-green-blue ‘TV monitor’ icon near the bottom of the screen on the client system. For a Windows’ system, the icon is placed in the task tray; on Macintosh

systems the TriCaster 'swirl' is placed in the dock. This indicates this computer's display is ready to send to TriCaster.



Figure 16 – iVGA source on LIVE Output

Select the second computer by name, and you will see the designated screen from the remote computer displayed in the VGA monitor.

Click **Ext** on the **Preview** row and it is ready to transition to Live.

3.2.4.2 LIVETEXT™

NewTek's LiveText™ application offers features that are very similar to TriCaster's **Edit Text** (see Section 3.5 and Chapter 7, Edit Text), but installs separately on a compatible Microsoft Windows® computer.

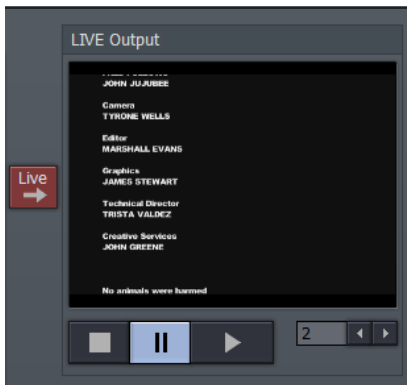

Figure 17

A workstation with LiveText installed effectively constitutes a dedicated CG and Title solution for TriCaster presentations. (This is a wonderful addition for those times when you could really use another pair of hands.)

When running on the network connected computer, LiveSet will be listed in the External Source menu, similar to an iVGA source (but in the **Applications** group.)



Figure 18

When enabled, the current LiveText page will be available as the **Ext** source for assignment on TriCaster's Switcher or in its **Overlay** panel.

For more information on installing and using this great tool, please refer to the LiveText manual.

3.2.5 DDR (& PICTURE)

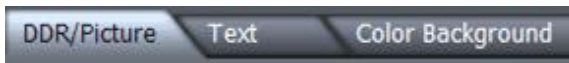

Figure 19 - TriCaster and TriCaster PRO



Figure 20 - STUDIO and PRO

Video is a great way to improve a presentation, so let's add some clips. Click the **DDR** tab (in the row below the **Switcher**), and click the **Add** button.



1. Navigate to the D:\Media folder, and add 4 or 5 videos from the folder D:\Media\Clips.

Figure 21

2. Make sure that **List** mode and **Loop** mode are selected in the DDR Playback Mode section
3. Under the **DDR** preview monitor at above-left on the TriCaster desktop, click **Play** (the triangular button) to run your clips. Again, you can choose **DDR** on the Switcher's **Preview** row and transition to the video when you want it.



Figure 22



Figure 23 - Playback controls vary slightly between models

There is an even more powerful way to play these clips: **Cue** mode. Cue allows you to transition to a video clip as it begins to play, and transition back as it completes.

4. Click Stop on the DDR control (if a clip is playing.) Turn **Selection** on and **Loop** off in the DDR panel

5. Select **DDR** on the Switcher's **Preview Row**.

6. Click the Pause button under the DDR window, and then press Cue (three buttons, Cue, Pause and Play will light up.) Your DDR is now armed for precisely timed playback.
7. Press Enter to trigger a Take and you'll see the video clip begin playing at once. Press Enter again, and the clip pauses where it is, and returns to Preview position.
8. With DDR selected on the Preview row, change its behavior from List to **Selection** mode. (This will unlock Cue, so you'll need to click **Pause** again under the DDR window.)

Pressing Enter on the keyboard now will play the clip, as before -- but the DDR will Auto transition back to Preview just before the clip reaches the end. You don't need to do the switch manually.

Better yet, the next video in line in DRR is automatically cued and ready to roll.

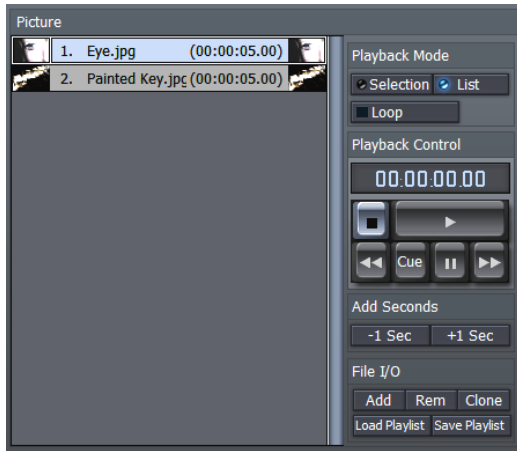

Figure 24 - PRO Picture module

TriCaster and TriCaster PRO's **DDR/Picture** tab also features a **Picture** player. You can use this to display still image files.



Figure 25 - Hotlist link

Load 5 or 6 images from the D:\Media\Pictures\ folder by clicking its **Add** button. When the Select Files requester opens, click on the **Hotlist** button labeled "Pictures" at the bottom. Control-click several of these (to multi-select them), and then click Add in the lower right corner of the requester.

You are now armed with a combination of on-demand still and video playback. Pictures are auto-sized for playback.



The PRO model Picture player has additional Playback Mode controls:

Set a duration for the image (the default is 5 seconds, or modify it using the +/- 1 second buttons.)

Loop determines whether playback loops or stops at the end. The Cue button works like its DDR counterpart described earlier.

3.2.6 TEXT AND TITLES

What about titles? TriCaster provides powerful titling and CG tools, including quick and easy title templates. Click next on the **Text** tab, and we'll quickly add a title page.

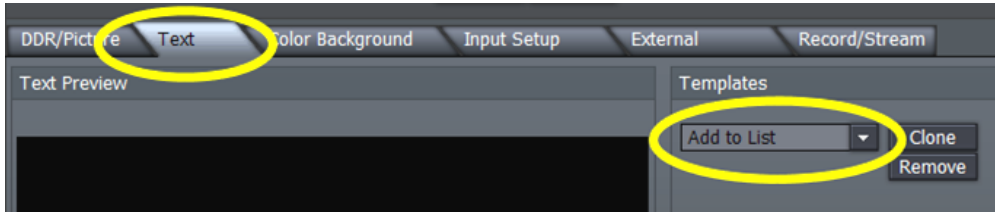

Figure 26

1. Click the drop-down triangle beside **Add to List** (see Section 4.4.1.1) to reveal a menu listing a huge number of professionally prepared templates.

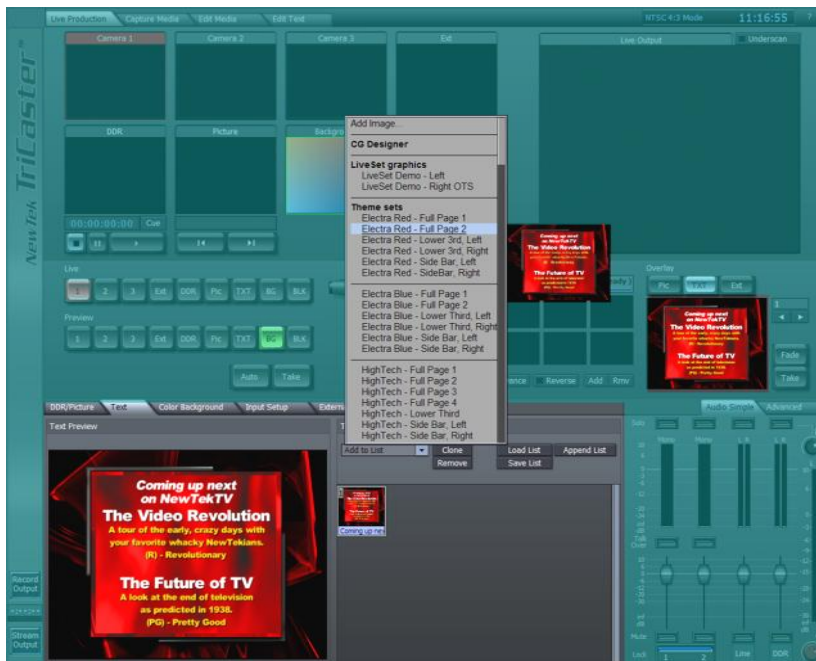

Figure 27

2. Click on a lower-third title, such as the one shown above. A thumbnail for the page is added to the playlist panel below.



Figure 28 – TriCaster Overlay panel

Now click the **Clone** button to duplicate the entry, and then click directly on the second thumbnail. This activates the duplicate template visible in the title editing pane at left.

In the editing pane, clicking on any text will pop up a text-entry field. Click inside it to replace the current text with something new. Then, press Enter to complete the change.

On the line beneath it, continue to modify the headings. You can add more template pages and tweak them if you wish.

Now to cue up the title page:

3. Click the **Text** button in the **Overlay** control area (located to the right of the **Transition** banks (Figure 28.)
4. Then double-click one of the page thumbnails you modified. The page appears in the small **Overlay** preview panel, permitting you to verify your choice of the title page before actually activating the overlay.

Use the **Fade** and **Take** buttons under the **Overlay** window to display the selected overlay (in this case a Text page) on top of your Live source.

3.2.7 COLOR BACKGROUNDS

TriCaster also includes a Color Background generator.

Include these backgrounds in your presentation by clicking the **BG** button at the extreme right of the **Switcher** rows.

The backgrounds generated can be used behind **Overlay** pages, as a background for LiveMatte effects or other purposes.

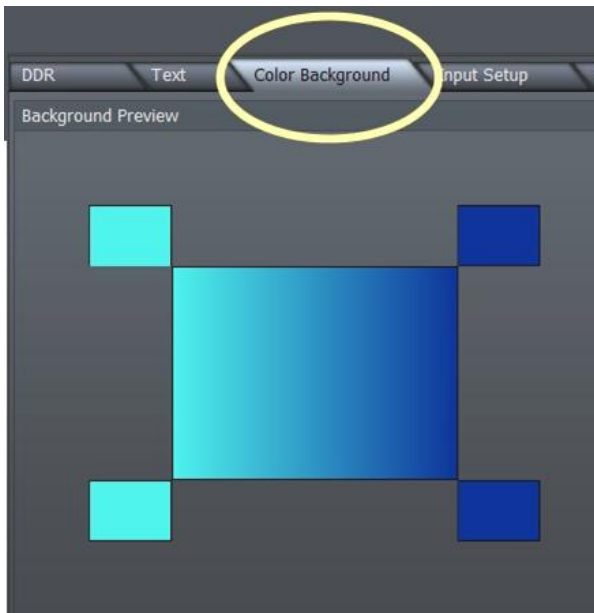

Figure 30



Figure 29

The **Color Background** tab has three sections -- the **Background Preview, Mode** and **Presets** panes. (The Horizontal *mode* is shown above - two colors are blended from left to right across the display.)

When you left-click on any of the four outer square patches bounding the Preview pane, the **Pick Color** window appears. Using it, you can assign a color numerically - or by clicking directly on its palette pane.

Hint: to match a specific color in your imagery, right-click on the square instead, then hold the button down as you drag to the point you wish to pick the color from (the square will update as you drag the pointer around the screen, showing the color under the pointer at any moment – release the button to make your selection.)

The **Preset** section allows you to easily recall frequently used background combinations. Set up the Preview pane to taste, then Click **Store** followed by a Preset button to assign it.

3.2.8 LIVEMATTE

TriCaster's **LiveMatte** keying system removes a specified color range – the 'key' color – and a tolerance factor on either side of it from one video or image source, replacing it with material from another source.

The best known application for chromakeying is seen during TV weather broadcasts: In the studio, the presenter stands in front of a green screen. The green (key) color is replaced with computer graphics by the chromakey system.

TriCaster's LiveMatte provides a very high quality yet easy to use keying system.

To begin our exploration of LiveMatte's basic operations, we will select some suitable source material. (You may not be all set up with a greenscreen studio, so NewTek has supplied some Demo clips for this purpose, already installed on your TriCaster!)

1. In the DDR tab, remove any clips you previously added, then **Add** the video clip D:\ Media\Clips\ DemoContent\Cam-XCloseUp.avi

(Jump to the 'Clips' folder by clicking its Hotlist button at the bottom of the 'Select Files ...' panel.)

2. Turn on **Selection** and **Loop**, and click the **Play** button (either in the DDR panel or under the DDR preview monitor above left.)



Selected TriCaster models feature an extra row at the top of the Switcher labeled "Effects."

LiveMatte effects are applied slightly differently on these models, as noted in a separate sub-heading coming up later in this section...

3. With the video playing, select the **DDR** on the Switcher's **Preview** row. (This allows you to judge your LiveMatte settings without your audience seeing.)
4. Click the main **Color Background tab**, and choose a nice gradient background.

3.2.8.1 LIVEMATTE AND THE SWITCHER



Figure 31 – standard TriCaster

The Switcher in the standard TriCaster has two rows - **Live** and **Preview**. When a LiveMatte enabled source is selected on the Live row, imagery from the Preview row source shows through wherever the key color is removed.



Figure 32 – PRO, and STUDIO / BROADCAST in three-cam ISO mode

Other TriCaster models (PRO, STUDIO and BROADCAST) sport a third Switcher row labeled **Effects**. The source on the Effects row provides the background imagery used to replace the LiveMatte key color on these models.



Figure 33 – STUDIO and BROADCAST in six-cam mode

To create a LiveMatte effect showing the Color Background you’ve arranged behind the demo clip in your DDR, follow the steps below (that correspond to *your* TriCaster):

TRICASTER

1. Select the BG button on the Switcher’s Live row. This marks it as the backdrop source for LiveMatte.
2. Select the DDR button (for the DDR with your demo clip in it) on the Switcher’s Live row. This marks it as the foreground source for LiveMatte.
3. Click Input Setup Enable the **Follow Preview** switch

PRO, STUDIO, AND BROADCAST

1. Select the **BG** button in the Switcher’s **Effects** row. This marks it as the backdrop source for LiveMatte.
2. Select the **DDR** button in the Switcher’s **Preview** row.





4. Enable the main **LiveMatte** switch

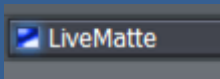

5. Click the **Pick Color** button, and keep the mouse button depressed.
6. Drag the **eye dropper** (cursor) up to the **Live** preview monitor. Release the button over the background green color, assigning it to the 'key color' swatch.
7. Adjust the **Tolerance** value until all the green pixels are transparent, allowing the Color Background to show through.



(In modes with a dedicated Preview monitor, you can tweak LiveMatte before displaying the result to your audience.)

3. Click **Input Setup**

4. Enable the main **LiveMatte** switch

Enable the **Follow Preview** switch

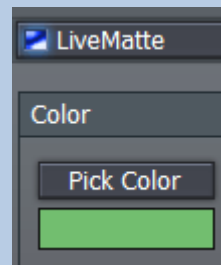

5. Click the **Pick Color** button, and keep the mouse button depressed.
6. Drag the eye dropper (cursor) up to the **DDR** Preview monitor. Release the button over the background green color, assigning it to the 'key color' swatch.
7. Adjust the **Tolerance** value until all the green pixels are transparent, allowing the Color Background to show through.
8. Click the Switcher's **Take** button (or press the Enter key) to send the LiveMatte enabled source from the **Preview** row to **Live** output.

You should immediately see your onscreen talent displayed above the colored background you created.

Hint: LiveMatte settings also play an important part in connection with NewTek's LiveSet™ technology! Please refer to Chapter 8 (LiveMatte, LiveSet, Live Action!) for more detail on this astonishingly powerful part of your system.

Again, TriCaster models with the third Switcher row (**Effects**) make it a snap to set up the effect (foreground on Preview, and background on Effects) unseen by a live audience – then switch to the combined LiveMatte effect directly from a third source.

Naturally, as befits the name, LiveMatte works wonderfully with live sources as well! We'll discuss other more advanced LiveMatte settings later on in the manual.

3.2.9 AUDIO

TriCaster's live audio mixer is a very simple way to integrate presentation audio.

Connecting microphones and/or audio inputs to the system is easy, as external connectors are clearly labeled to avoid confusion.

The LIVE Audio Mixers of the various members of the TriCaster family bear several common features.

For example, the **Audio Simple** tab provides volume sliders and **VU** meters for each input (including the DDR.)



Figure 34 - Audio Simple tab (TriCaster)



The **Audio Advanced** tab gives access to individual equalization controls for each input.

As well, a red **Master Audio** knob at lower right (with a master VU meter directly above) is always visible.



Figure 35 - Advanced tab (TriCaster)

Selected models have a third tabbed panel in the audio Mixer – **Setup**.

The controls in the Setup tab are the audio equivalent of the video section Input Setup panel.

They permit you to assign **Microphone** or **Line** level impedance to certain inputs, or a custom gain setting, as well as toggling **Phantom Power**.



Figure 36 - Setup tab (STUDIO)

3.2.10 INTERNET STREAMING



Sending your output to the world can be as easy as connecting TriCaster system to the Internet (or intranet), and pressing the **Stream Output** button on the lower left corner of LIVE Production.

Figure 37

*TriCaster offers two different streaming modes -- **Push** and **Pull**. Push streaming is generally the most convenient, and can be easily arranged with your streaming provider.*

A number of optional settings for configuring the streaming output are located in the panel that is displayed when you click on the Record/Stream tab (near the center of the main LIVE Production screen.)

These controls and options, along with various other factors you may wish to consider (especially if your plans involve broadcasting to a large audience) are discussed further in Section 4.10, Record or Stream and in Chapter 10, entitled Streaming, Networking and the Internet for more detail (this chapter will help you integrate your TriCaster into environments involving various external hardware components.)

3.3 CAPTURE MEDIA

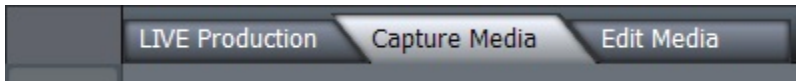

Figure 38

The **Capture Media** tab is used to acquire (standard definition) video and audio from cameras, decks, and other sources.

Note: TriCaster programs and utilities are installed on the C: drive, while your media folders are on the D:\ partition (this is where you will capture your video clips, audio files and pictures.)

The Capture Media screen is divided into four sections: **DV Camera Control**, **Capture Control** beneath that, **Capture Details** to the right, and the **Captured Files bin** across the bottom. If you connect a camera or deck to TriCaster using IEEE 1394 (known as FireWire^(TM), or often simply "DV") you have the benefit of capturing audio and video across one cable and the added advantage of device control for play, pause, fast forward, etc.

Let's capture a bit of video now:

Using a suitable FireWire cable (not supplied), connect your DV camera or deck to a 4 or 6-pin FireWire connection on the TriCaster (the front connector is marked with the FireWire symbol, resembling a stylized "Y").



Figure 39 - TriCaster STUDIO

After a moment or two for your system to recognize the new device, the **DV Camera Control** pane acknowledges the connection with a confirmation message, and displays the time code position of the tape at upper right. The transport controls beneath the timecode activate, and you can now fast-forward, rewind, play and pause on screen.

NOTE: For analog video captures, you must connect a composite, S-Video or component-video cable to one of the TriCaster inputs.

Likewise, connect audio cables to the corresponding Line input connector. Then activate the proper input (composite, S-Video or component) in the Capture Details panel

Manually controlling your camera or deck, use the Capture controls as described here.

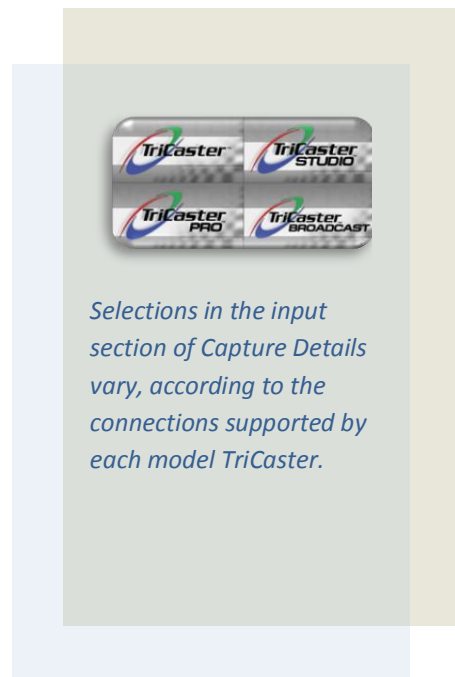

Selections in the input section of Capture Details vary, according to the connections supported by each model TriCaster.

Ensure that the blue LED-style indicator next to DV is illuminated in the Input (source) selection in the **Capture Details** pane.

It is recommended that you save projects in their own folders, and TriCaster has buttons in the **Hotlist** area along the bottom of the Media Bin that make it easy to quickly jump to where you need to go.

Let's begin by navigating to the D:\ drive - click the 'TriCaster' tag in the **Captured Files** window, and then *double-click* on the D: drive in the window.

Now, let's make a new folder for this test capture. Right-click in a blank section of the **Captured Files** window; then click inside the popup name dialog that appears under the mouse pointer. Type in a folder name (such as "Test Captures"), and press Enter on the keyboard.

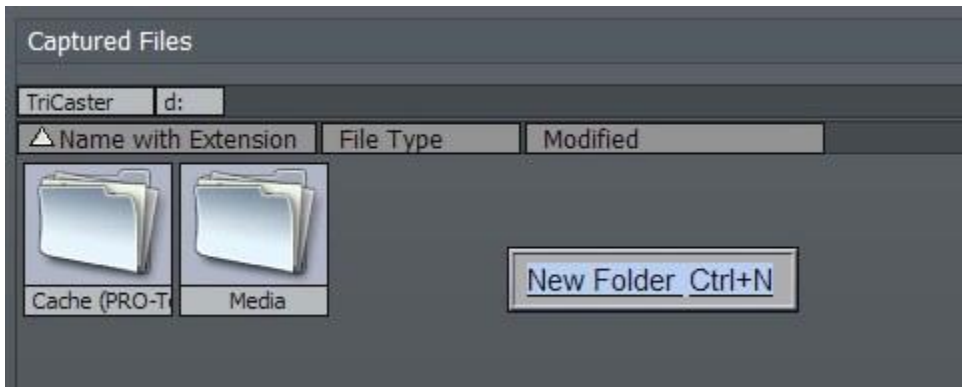

Figure 40

The new folder appears highlighted in the media window. Double-click it to enter. We want to quickly return to this location for live and editing sessions, so click on the small [+] sign at the lower left corner of the file pane. This creates a new button at the bottom of the window, labeled D:\Test Captures.

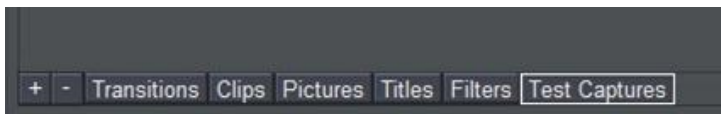

Figure 41

Let's shorten that a bit. Right-click on this button and choose **Rename Tab**. Then remove the "D:\\" so it just reads "Test Captures."

HINT: We recommend you organize your projects and captures in primary folders this way, with subfolders for video, audio and pictures. That way, everything remains centralized for easy access, removal, and archiving when the project is completed.

Roll the tape to the point you wish to capture, and press **Capture**. You'll see the display incrementing how long this clip is in minutes, seconds and frames. As you press **Stop Capture**, the clip will appear in the Captured Files folder at the bottom.



The [||] button will **Pause** your capture, and the **Picture** button will grab a still image from moving video, and store it as a JPEG file.

HINT: TriCaster offers instant clip playback from the Captured Media window by double-clicking the clip. (The clip will run in the Capture preview window, as well as on the Live output stream.)

As you capture, note the audio levels and adjust the incoming volume to maintain the signal below 0 dB.

Figure 42

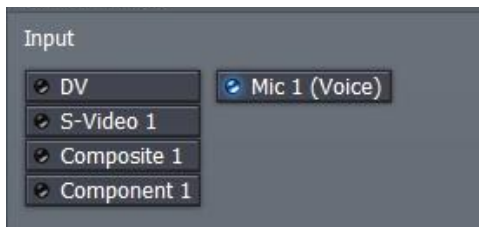

Try to keep audio as close to 0dB as possible *without* going over (audio peaks hovering in the -6 to -3dB area are good (of course, audio via IEEE1394 is transferred at its original levels.)

If you wish to record narration, select **Mic 1 (Voice)**.

Figure 43

The Capture Preview monitor switches to a waveform view (Figure 44), and then you can use the capture controls as described above.

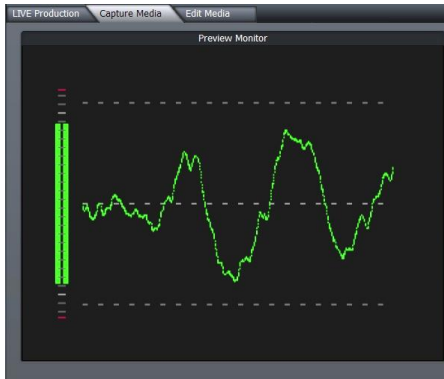

Figure 44

As you record clips the **Hard Drive Space Available** gauge will show how many gigabytes or megabytes you have free.

HINT: To import picture or audio files, you can transfer them to TriCaster in any of several methods: USB or FireWire flash thumb drive or external hard drive, or via the local network.

3.4 EDIT MEDIA

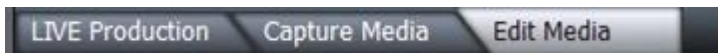

Figure 45

The **Edit Media** tab enables you to create practically any video project you can imagine -- from simple, 'cuts-only' projects to longer and more elaborate presentations with titles, multiple video layers, high-end transitions, slow motion effects and numerous other digital video effects.

The edit screen is divided into three main sections:

- Playback controls and the primary Edit Project Monitor in the upper left quadrant
- The tabbed upper right section providing file access and advanced editing functions
- Across the bottom, the edit workspace, where you assemble your project using either the **Storyboard** or **Timeline** view



HINT: There are benefits to both Storyboard and Timeline views -- each is explored in greater depth in the editing chapter of this manual.

For now, let's build a simple project and then explore some of the things we can do to spice it up.

In the **Edit Media** tab, click on the **Media Bin** - in the upper right part of the screen. This is where we locate files we want to work with. At the bottom of the bin window, click on the **Clips** button in the **Hotlist** (to jump to the folder D:\Media\Clips)

3.4.1 STORYBOARD

At the top of the edit workspace, click the **Storyboard** tab. The Storyboard is a simplified view of all your project assets in sequential order. Hold down the **Ctrl** key and click on 5 or 6 clips in the Media bin pane, then drag the selected group into the Storyboard window.



Figure 46

Clip adjustment is quite easy in the **Storyboard**. To adjust the beginning of the first clip in our new project, place the cursor over the left half of the clip, and hold the **Alt** key. The cursor changes to 'IN' and the left/right arrows are a hint that by holding the left mouse button down and dragging left or right, you can choose a new starting point for this clip.

Continuing to hold the **Alt** key, place the cursor over the right half of the icon, and the cursor changes to 'OUT' allowing you to choose a different last frame. Adjust the other clips to your liking, and play your project by tapping the **Spacebar** (tapping the Spacebar alternately pauses or begins playback.)

Automatically add a dissolve transition to a clip by clicking on it, then pressing **Alt-f**.

Hint: If nothing is selected in the editor, then **Alt-f** adds fades between everything that is not an overlay. Now highlight one clip, and holding down the **Shift** key, click on another several clips away to highlight the whole range. Pressing Alt-f again adds transitions to just the selected range.

If you have a specific transition you'd like to add, click the **Transitions** Hotlist button at the bottom of **Media Bin**. There are hundreds of transitions you can insert between clips.

Undo that last change by pressing **Ctrl-z**. Press **Home** to jump to the start of the project, and **Spacebar** to play.

3.4.2 TIMELINE

Storyboard view is limited to sequential clip display. **Timeline** view, on the other hand, allows for complex layering.

Click on the Timeline tab for a different view of your project. If you cannot see all clips, double-click on an empty spot in the Timeline to auto-fit the project.

Let's add some audio to our project.

Note: unlike some other edit software, TriCaster's Timeline does not restrict audio samples, video clips or transitions to specific areas of the project window. They can be freely mixed and repositioned as needed.

We're already viewing the contents of the Clips folder in the Media Bin. Drag an audio file (sound samples usually have the file suffix ".wav") into the project, placing it in the Timeline beneath the video clips at the start of the project.

3.4.3 CONTROLS

To edit this file, click on the **Controls** tab at the top of the screen. This panel changes views based on the type of clip selected in the editor. When any audio clip is selected you can modify levels and set keyframes for them. Note the time bar across the top of Controls view that shows where we are within this clip.

Let's pan this music file from left to right over the duration of clip:

- Go to the beginning of the audio file and set the **Balance** slider to far left, then click the **Keyframe** button to set it.
- Play or scrub to the end of the clip, and slide Balance to far right. (Note as soon as you move Balance, Keyframe activates. Keyframing is automated, and only the first setting needs to be marked by clicking Keyframe.)



Figure 47

When you play your file back, you'll see **Balance** slide from left to right.

3.4.3.1 TRANSFORMING VIDEO

The **Controls** tab allows even greater flexibility while editing the video portion of a clip.

Go back to **Media Bin**, and drag a video clip underneath this audio clip. Come back to Controls view to see the clip in the Controls window, with a list of options beneath it.

To overlay this over the existing clips, activate the **Overlay** button to the lower right, or press the 'y' key.

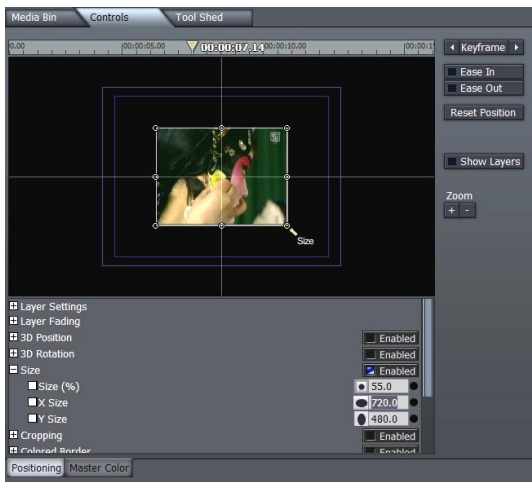

Figure 48

Scrub (drag the cursor in the time scale) to the middle of the clip and drag the scaled down image in the preview window to the center of the screen; then scrub to the last frame and place the image at any other corner (setting another keyframe automatically.)

Press **Play**, and you'll see that you quickly created a background layer with a smaller, moving layer on top. To help separate the two, click the Enabled button on the Shadows control and play again.

3.4.3.2 ROTATION

You also have full 3D rotation, which can be adjusted by moving the cursor outside the edge of the clip until you see the tool hint 'Rotate'. Left-clicking and dragging rotates along the z-angle.

Right-clicking and dragging left or right rotates on the Y angle. Dragging up or down rotates along X.

Now, place your cursor over one of the corners of the clip in the controls view and see 'Size' appear below the cursor. You can now left-click and drag inward to shrink it down on top of the existing clips.

Left-click in the center of the clip and drag it to the upper left corner, keeping it within the inner blue box. Click **Keyframe** to set this beginning position.

Scrub (drag the cursor in the time scale) to the middle of the clip and drag the scaled down image in the preview window to the center of the screen; then scrub to the last frame and place the image at any other corner (setting another keyframe automatically.)

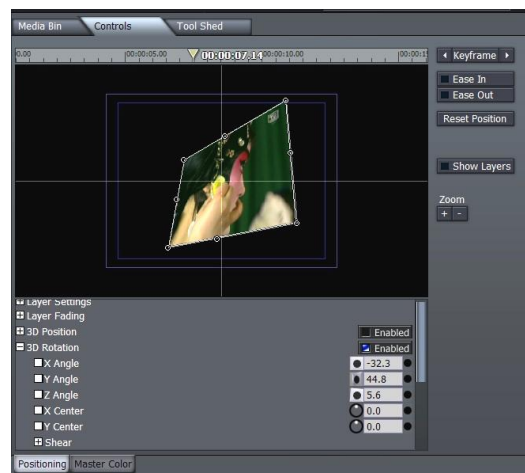

Figure 49

To crop this clip, you move the cursor just outside one of the clip edges in the controls view until the cursor hint changes to **'Crop'**. (Dragging with left mouse button will crop all four edges; the right mouse button affects only the selected edge.)

Soft edges are also desirable, and we can do that here too! Move the cursor just inside the edge of the clip (so the cursor hint reads **'Smooth'**) and drag inward.

3.4.3.3 SLOW MOTION

If you need slow motion, simply place the mouse over the edge of this clip, then pressing the **Alt** key (note the cursor changes from IN or OUT to **'Stretch'**) and left-click and drag the clip to make it longer.

Dragging the clip to twice its length will cause playback at 50 percent speed.

You can now adjust the in and out points of this clip, and the speed will remain as set.

3.4.3.4 COLOR CORRECTION

If we wish to color correct this clip, scroll down the Controls window to Color Correction near the bottom. Click the '+' symbol to reveal our options. Place the time bar at the beginning of this clip, and Press the Keyframe button upper right.

We have now set full color at the beginning. Scrub to the middle of the clip and change Saturation to 0.00. Click Keyframe. Now our clip slides from full color to black & white.

3.4.3.5 FADE IN/OUT

Instead of having this clip abruptly appear, we can fade it in. In Timeline mode, note each clip has a small white triangle at lower corners. Position the cursor over this corner and when it changes to 'Fd', you can now left-drag that inward. Do this on both sides of the clip, and now our picture-in-picture smoothly fades in and out. You can also position clips off screen and move them in during playback.

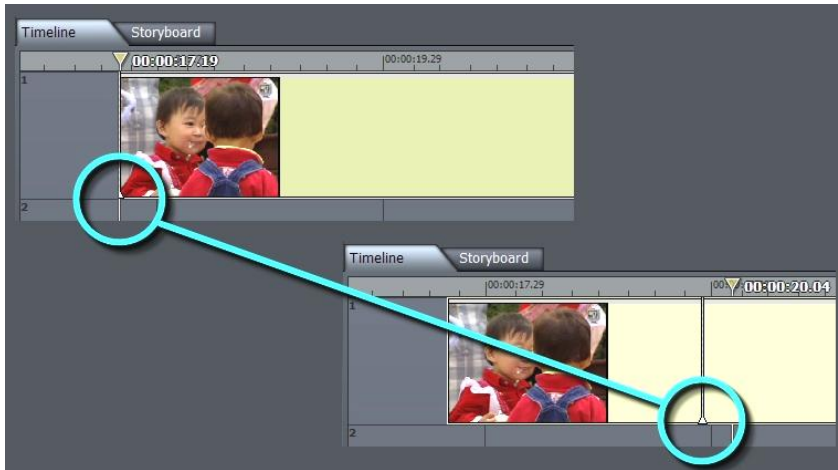

Figure 50

3.4.3.6 CHROMAKEYING

The **Media Editor** also allows real-time **chromakeying**, removing colored sections of a clip. To see this, drag a greenscreen demo file from the Media Bin's Clips folder into the Timeline – place it beneath another video clip.

Click **Overlay** to the right and return to **Control** tab. At the bottom of the controls list, click the '+' next to **Chroma / Lumakeying** to reveal its options. Select the color of the green screen by right clicking in the **Key Color** selector, and, holding the right-mouse down, drag the eyedropper to the Project monitor.

To make this color transparent, click to enable **Chromakey** (the middle button of three above the color well.) On playback, you now have the foreground of the greenscreen video layered on top of your base clip.

Another place rich for exploration is **Tool Shed**, automating many routines used in day-to-day editing. We'll postpone that discussion until a bit later, though.

3.5 EDIT TEXT

The Edit Text panel provides you with deep professional character generation facilities. You can use it to design and manage great looking still and animated text and graphics for your productions (whether Live or Edit Media projects.)

For live production purposes, Edit Text panel creations can be utilized as **Overlays**, supplied by the **DDR** or **Picture** modules, or as custom templates for the **Text** module. Alternatively, you can even create a custom **LiveSet** for use in **Input Setup**. And of course, exported title/cg pages can be used as graphic elements in **Edit Media** projects too.



Figure 51

The sheer depth of the **Edit Text** panel disqualifies it for coverage here in the Quick Start chapter, but if you have some previous familiarity with graphics applications you'll find its intuitive nature allows you to jump right in.

Please refer to Chapter 7, Edit Text, which provides much more detailed information.

4 LIVE PRODUCTION

The main **LIVE Production** screen (for all TriCaster models) is divided horizontally into three sections: The uppermost third is the **Monitoring** section. The central section is devoted to **Live Control**. The bottom third is contains **Setup and Audio** modules.



Figure 52

4.1 MONITORING

The number and type of available video sources varies between TriCaster family members. Naturally then, the monitoring section reflects this diversity.



Figure 53

As well, TriCaster STUDIO and BROADCAST offer alternate operating configurations - including **6-Camera** or **3-Camera** (ISO) modes (see Section 3.2.1, LIVE Operating Modes.) The layout and functionality of the onscreen monitors adapts itself to suit the configuration you choose.

We'll consider the various configurations in turn, beginning with the simplest variant and then moving on through the more advanced models.

4.1.1.1 TRICASTER (3-CAMERA)



The original TriCaster presents the simplest LIVE Production monitoring section. At upper left are dedicated (ISO) monitors for all three main video Inputs (composite or Y/C, according to your settings in Input Setup.)



Figure 54 - TriCaster

Beneath these, a second row of three monitors shows the current item in the DDR and Picture player playlists, and the (TriCaster Generated) Color Background. Two more small monitors in this section show 1) an external source (Ext) such as an iVGA input configured in the External Tab, and 2) a computer generated “Black.”

*Note that the source currently selected on the **Live** row is highlighted in red, while the current Preview row selection has a thin green outline.*

4.1.1.1 INTERACTIVE FEATURES

The small preview monitors are *actually* interactive live production controls! You can use these to perform many operations that you might otherwise do using the Switcher.

Here’s a list of things to try:

- Click on an unselected monitor to place it on the **Preview** row
- Click the small monitor assigned to **Preview** to perform a **Take** (swapping it with the current Live row source and sending it to **LIVE Output**.)

- Double-click any unselected monitor to place it on the **Live** row (moving the previous Live source to Preview.)
- Shift + click the small monitor assigned as **Preview** or **Live** monitor to Auto between them.
- Shift + click any monitor to Auto to it on **Live** (sending the original Live source to Preview.)

(Observe that the **Cue** switch responds normally when you switch interactively in this manner.)

HINT: Take advantage too of the keystroke shortcuts mentioned in the Switcher discussion which follows!

4.1.1.2 LIVE OUTPUT

At right, a larger monitor is provided so that you always know exactly what your current program output stream is displaying.

(The **LIVE Output** display included any active effects and **Overlays**.)

By default, the program view is slightly cropped, just as it would be viewed on most television sets.

The LIVE Output **Underscan** switch at upper right causes the monitor to display the entire program right to its edges.

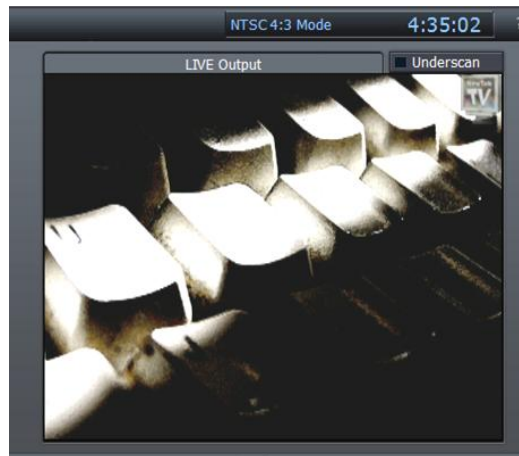

Figure 55 - TriCaster

Enabling Underscan only affects the onscreen monitor view, without any effect on the outgoing signal. Nevertheless, it can be useful as many projection systems display the (normally unseen) overscan area.

4.1.2 3-CAM ISO MODE (PRO, STUDIO & BROADCAST)



For 3-Camera models (and modes), the left-most half of the Monitoring section is likewise occupied by eight small preview windows. These always display the sources currently available for assignment in the **Switcher** rows below.

Monitors for three live **Camera** inputs are provided, along with previews of the either the **DDR** and **Picture** (PRO version) or **DDR 1** and **2** (STUDIO and BROADCAST) module content.



Beneath DDR monitors are **Cue**, **Stop**, **Pause** and **Play** buttons. (These function just like the controls in the DDR panels, accessed via the DDR tab below.)

The remaining small monitors show the current **Color Background**, **Ext** source and **Black**.

Figure 56 - PRO, and STUDIO/BROADCAST in ISO mode

4.1.2.1 INTERACTIVE FEATURES

The 8 small preview monitors are actually interactive live production controls! You can use these to perform many operations that you might otherwise do using the Switcher. Here's a list of things to try:

- Click on an unselected monitor to place it on the **Preview** row
- Click the small monitor assigned to **Preview** to perform a **Take** (swapping it with the current Live row source and sending it to **LIVE Output**.)

- Double-click any unselected monitor to place it on the **Live** row (moving the previous Live source to Preview.)
- Shift + click the small monitor assigned as Preview or **Live** monitor to Auto between them.
- Shift + click an unselected monitor to Auto to it on **Live** (sending the original Live source to Preview.)

(Observe that the **Cue** switch responds normally when you switch interactively in this manner.)

HINT: Take advantage too of the keystroke shortcuts mentioned in the Switcher discussion which follows

4.1.2.2 PREVIEW AND LIVE OUTPUT

The right-hand half of this upper section is split between two large monitors:

The one at far right shows the **LIVE Output** (the program stream) including any active effects and **Overlays**.) Just to the left is the **Preview** monitor. Normally this offers a preview of the source selected on the Switcher's **Preview** row. Additionally, however, when you are using the 3-Camera configuration only, a drop-down menu below allows it to serve double duty as a realtime **Waveform/Vectorscope** display of the signal from Preview.

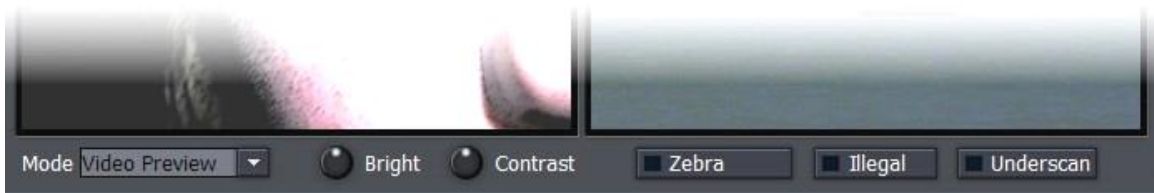

Figure 57 - PRO, and STUDIO/BROADCAST in ISO mode

Also beneath these two larger monitors (Preview and LIVE Output) are **Bright**(ness) and **Contrast** knobs, along with switches that toggle **Zebra**, **Illegal Color** and **Underscan** options. (These features all affect both of the large monitors.)

4.1.3 6-CAMERA MODE (STUDIO, BROADCAST)



The two top-of-the-line TriCaster models both permit simultaneous live switching of as many as six cameras.

To accommodate so many sources, the monitoring section is laid out a bit differently.



In this case, TriCaster does not display full-time ISO monitors for all sources.

Instead, a quad-display which includes the DDR and Ext sources is shown, along with a *full-time* Waveform/Vectorscope pane.

Figure 58 - STUDIO & BROADCAST, 6 Cam mode

In six camera mode, the small monitors are not interactive. (Instead, the main Preview monitor is used to preview the video source cued up on the Switcher's Preview Row.)

4.1.3.1 PREVIEW AND LIVE OUTPUT

The right-hand half of this upper section is split between two large monitors.

The one at right shows the **LIVE Output** (the program stream) including any active effects and **Overlays**.) Just to the left is the **Preview** monitor which displays the source selected on the Switcher's Preview row.



Figure 59 - STUDIO & BROADCAST, 6 Cam mode

Also beneath these two larger monitors (Preview and LIVE Output) are **Bright**(ness) and **Contrast** knobs, along with switches that toggle **Zebra**, **Illegal Color** and **Underscan** options.

Note: These latter controls and features are global, and affect both the large Preview and LIVE Output monitors. Unlike the Proc Amp controls in Input Setup, however, they have no effect at all on the actual program stream.

4.2 LIVE CONTROL

This central section ultimately determines the composition of your **LIVE Output**. It contains the **Switcher** and **Transition** panels, along with the **Overlay** section (used to add graphics, titles and so on to your output stream.)

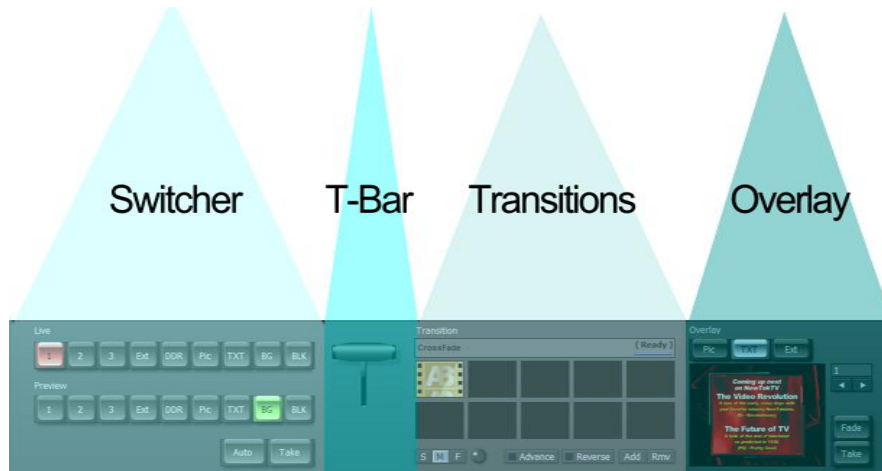

Figure 60

The rows (two or three, depending on TriCaster model) of the Switcher section at left are where you manage video sources to create the main video output stream. Clicking the buttons in these rows to assign the source displayed on **Live**, cued up **Preview** (shown in the Preview monitor), as well as a supplementary source assigned to **Effects** (selected models only.)

To the right is the **T-Bar**, used to perform a transition between the sources assigned on the **Main** and **Preview** rows of the Switcher. Further to the right is the **Transition** panel, which allows you to pre-select from several banks of effects for switching between the content of the Live and Preview rows. The **Overlay** section allows you to configure a final effect (often a text or graphic) on the **Live** output stream.

4.2.1 THE SWITCHER AND T-BAR

Click **Auto** (or press the keyboard Spacebar) to apply the video effect selected in **Transition** to change from the Switcher's **Live** row source to the **Preview** row selection. Click **Take** (or the press the **Enter** key) to perform a straight cut to the **Preview** source.

To the right of the **Switcher** buttons is the **T-Bar**, which manually performs the currently active transition (which is highlighted by a white border.) To use the T-bar, pull it down by dragging it with the mouse pointer. When you drag it all the way to the bottom and release, the designated transition is completed and the T-Bar pops back to the top.

HINT: However you can also leave the T-Bar at an intermediate position, effectively using the selected transition to create a variable merge, interactively blending the two sources.

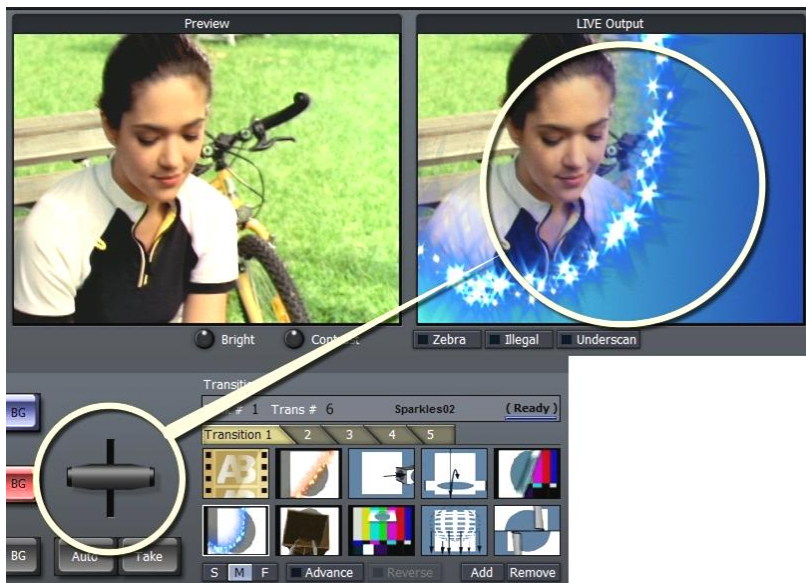

Figure 61

4.2.1.1 KEYSTROKE SHORTCUTS

You can use keystroke shortcuts to assign Switcher row selections (select (models have more options):

F1-F11: Set the **Main** row selection



1 – 0 and minus key (11) (main keypad): Set the **Preview** row selection

ALT+ 1 – 0 and minus key (11) (main keypad): Set the **Effects** row selection
(PRO, STUDIO and BROADCAST only)

4.2.2 THE TRANSITION BANK

TriCaster comes with hundreds of real-time transitions for use in live production. The five tabbed

Transition Banks are pre-loaded, but you can remove any or all of the transitions* and load different ones.



Figure 62

NOTE: The Fade cannot be removed, thus ensuring that TriCaster has at least one transition available.

Remove any transition by selecting it with the mouse and clicking the **Remove** button. In its place you can add a transition by clicking the **Add** button (you can also double-click in any empty well in one of the 5 tabbed **Transition Banks** to pop up a file requester.)

The file requester presents you with several folders, for different transition categories. Double-clicking the folder shows the transitions available, each with an icon representing its behavior. Shift-click (or CTRL-click) to choose several, and drag them to the Transitions bin. Dragging several transitions updates the current Bank with your selections.

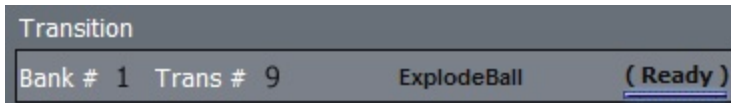

Figure 63

At the top of the Transition panel is a status line showing the current **Bank** and **Transition #**, the transition name, and – at right – a combination progress bar and **Ready** light. Some more elaborate transitions can take a moment or two to pre-load. This bar, when fully illuminated, indicates that the transition is now ready for use (during loading, its label will indicate “Loading”).

Along the bottom of the panel are additional options. **Advance** tells TriCaster to auto-advance to the next transition in turn when the current one completes. When it reaches the final transition, it cycles back to the beginning of the list. The **Reverse** option changes the behavior of the transition (a fly-in trajectory will fly out instead with Reverse selected.) There are also buttons to **Add** or **Remove** transitions from the bin.

HINT: The speed of the video effect will be set by the “S, M, F” buttons beneath the first column of Transitions. The Slow, Medium and Fast options correspond to ½ second, 1 second and 2 seconds respectively.

4.2.2.1 Keystroke Shortcuts

Access favorite transitions quickly and easily with two successive strokes of the keyboard number pad. The first keystroke (between 1 and 5) selects the **Transition Bank**. The next key (between 1 and 0) selects a specific transition.

(For example, pressing 1-1 (the number pad key 1, twice) pre-selects the Crossfade. Pressing 3-0 would preset the last transition in the third Transition Bank. (NumLock required)

4.2.3 OVERLAY

Completing the Transitions section of the screen is the **Overlay** panel.

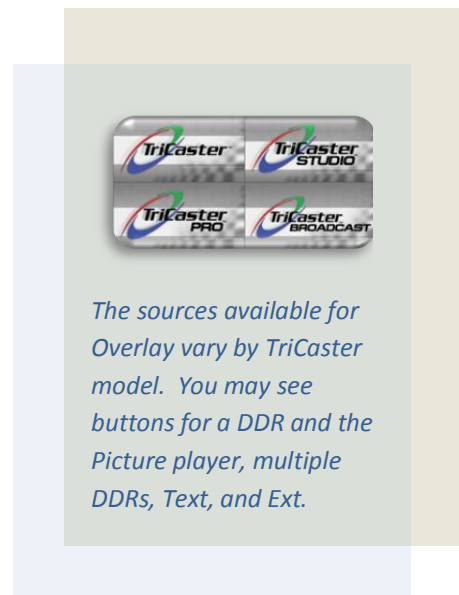



Figure 64 - TriCaster Overlay

Think of this section as a final opportunity to add something *on top of* the combined result of all other elements of your program stream just before final output!

Hint: The number display/entry field (above the Fade and Take buttons) and the arrow buttons beneath it permit you to choose a specific entry from the Text section.

Two more buttons, **Fade** and **Take** are found beside the Overlay panel's preview pane (which shows the current source you have designated.) These control the *way* the overlay is performed.

4.2.3.1 FADE AND TAKE

Click **Fade** to display the Overlay on the **LIVE Output** stream using a dissolve effect (using the current **Transition** speed setting.) Click again to fade it out. Likewise, clicking **Take** cuts the Overlay on and off the screen.

Overlay Fade *timing* is controlled by the Transition speed. This means that the Overlay transition is performed in sync with Switcher transitions.

Try this: select the **Crossfade** transition in the **Transitions** section, and set up a **Text** overlay that introduces the clip selected in your **Preview** row. When you press the 'a' key, a seamless transition from your **Live** source to the **Preview** source occurs, with perfectly timed introductory overlay! (After a moment or two, press 'f' to remove the title from view.)

4.2.3.2 Alpha Channels

Of course, if the source you choose to covers the entire video frame, it will completely obscure the primary output -- hiding all other elements. Unless bringing in a full screen billboard graphic, this would usually be undesirable.

Fortunately, overlays in this final pre-output stage fully respect transparency levels (or “alpha channel” values) of the selected (Overlay) source. Thus the primary display will ‘peek through’ transparent sections of the overlay.



Figure 65

Most of TriCaster’s Text templates have transparent regions, and are well suited as Overlays -- but you can also use many 32bit graphics file formats (files with embedded alpha channel) in the DRR or Picture modules in similar fashion.

When enabled as an Overlay, the embedded transparency of images and clips in the DRRs will be respected.

HINT: PNG (Portable Network Graphics) or Targa32 files serve well as file format choices for CG still overlays.

4.2.3.3 KEYSTROKE CONTROL

A number of *very* useful keystroke shortcuts are available:

f – Fade the Overlay (on/off toggle)

d –perform a **Take** of the Overlay display (on/off toggle)

s –**Take All**: swap the Main and Preview sources AND toggle the Overlay display on/off

a - Fade **All**: Fade the Overlay on /off and simultaneously Auto the Main and Preview sources.

4.3 SETUP AND AUDIO SECTION

This next section, comprising the bottom third of the screen, contains two tabbed rows of panels:

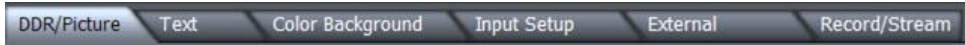

Figure 66 - TriCaster (Standard and PRO)

The larger set of tabs provides the means to configure, modify, and in some cases – create -- the video elements and sources comprising your program material, as well as recording it.

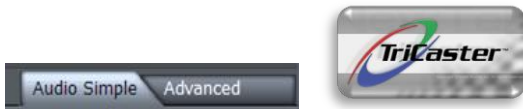

Figure 67 - Audio tabs (Standard)

The Audio tabs (whether two - as above - or three are provided on your particular model) offer similar configuration options and control over the audio part of your production.

Let's examine each tab in turn, beginning at the left.

4.3.1 DDR (AND PICTURE)

TriCaster's **DDR** (all models) and **Picture** modules (Standard and PRO models only) are designed to permit you to integrate video and still imagery into your live presentation with utmost simplicity and professional style.

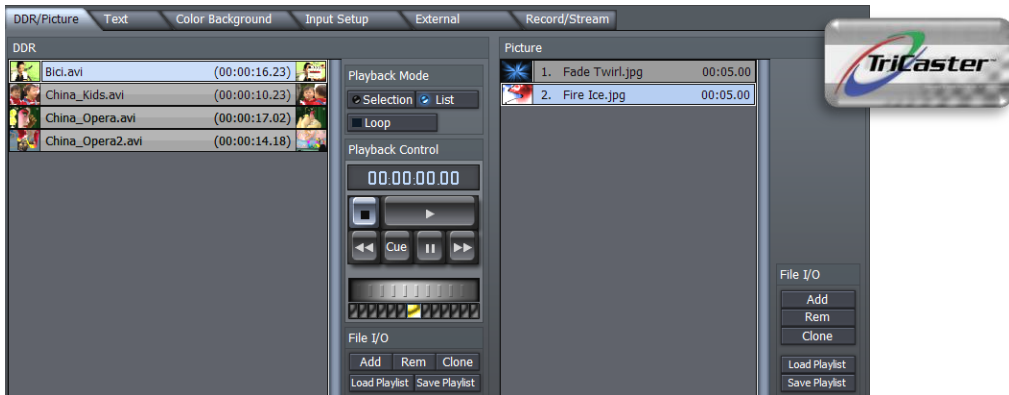

Figure 68 - DDR and Picture (TriCaster)

These modules are located in the **DDR** (or DDR/Picture) tabbed pane. When you click the tab, your TriCaster will display either 1) a **DDR** and **Picture** or 2) 2 **DDRs**.

You can preload content, and control its behavior on playback using the controls and options shown.

You can play multiple clips, single clips, and even have TriCaster perfectly roll your **DDR** on **Cue**, as it can 'listen' for **Switcher** commands. (The **Picture** module performs similarly, but provides extra control for setting up still images for display.)

These are powerful features and deserve attention, as they can help you achieve spectacular presentations!

4.3.1.1 THE PLAYLIST

The largest part of *both* the **DDR** and **Picture** modules is the **Playlist** pane, where clips or images you want to display as part of your presentation are organized and trimmed.

The natural display order for items in the **Playlist** is top-to-bottom. You can easily rearrange your Playlist sequence by dragging clips up or down.



TriCaster Pro boasts enhanced Picture module control. Please see Section 3.2.5 for more detail.

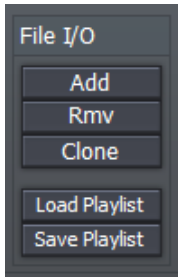

Figure 69

TriCaster's **DDR** accepts video clips in a wide array of standard formats, including AVI, Quicktime and other popular types. Like the **Picture** module (when present), it similarly accepts most common image formats, including JPEG, BMP, TARGA, PNG, and so-on. To **Add** a clip to the playlist, click the Add button in the nearby **File I/O** section. This pops up a file selection window. To quickly add a single file to the playlist, simply double-click it in the file window.

Alternatively, you can add many files at once by using Shift-click (click on a file, then hold **Shift** down while clicking another, to multi-select all files between the ones you clicked); then click the Add button at the bottom of the file window. Yet another very useful option is **CTRL-click** selection; single click as many files as you like with the CTRL key depressed, and when you click Add, they will be added to the playlist in the order you clicked them.

NOTE: Still images added to the playlist are automatically scaled to fit the live output format.

Click **Rmv** (or press **Delete** on the keyboard) to remove the selected clip(s) from the playlist -- but not from the hard drive. **Clone** duplicates a clip entry in the playlist, while **Load Playlist** and **Save Playlist** allow you to create and easily recall elaborate DDR setups.

4.3.1.2 TRIMMING CLIPS IN A DDR

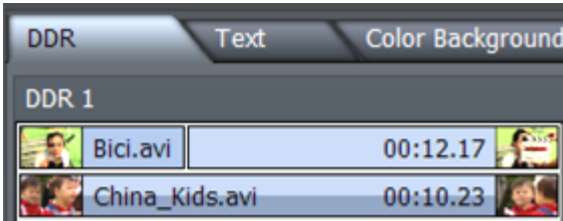

Figure 70 – Trimming

The **in** and **out** points (for playback) default to the first and last frames for each clip. Placing the cursor over the left-hand thumbnail and dragging to the right will move your **inpoint** timing, while dragging the right-hand thumbnail toward the left adjusts the **outpoint**. You can observe the effect of trimming in this fashion by watching the small DDR (or Picture) preview monitor above.

Another way to modify the In/Out point is to use the large jog wheel just below the transport control buttons (Play, Pause, etc.) When you are on the desired frame, press 'i' or 'o' on the keyboard to set in and out points, respectively. (Press Alt-i or ALT-o to restore the original start or end points.)

HINT: You can move through clips in precise single frame increments using the keyboard left and right arrow keys; CTRL+ arrow moves in 5 frame jumps.

A video clip without associated audio is shown as gray (or blue when selected) in the list. Clips *with* audio are two-tone, with a darker band horizontally across the bottom.

You can also perform some sophisticated setups in the playlist. If you have a clip with a needed duration, but want to slide over to a different section, hold down the Shift key while dragging either thumbnail. You can even set up split edits by setting an in or out point to the desired location, and then, holding the Ctrl key and dragging across the thumbnail adjusts only the audio segment of your clip.

4.3.1.3 SELECTION AND LIST MODES

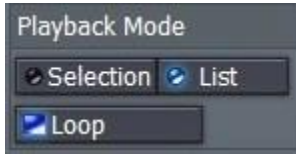

Figure 71

Selection and **List** modes modify to the playback behavior of **DDR** or **Picture** module. Selection mode effectively issues a **Stop** command *when the end of each clip in the playlist is reached*. Each clip is also treated as distinct if **Cue** or **Loop** is applied. **List**, on the other hand, treats the entire Playlist as one extended clip, proceeding from one video to the next until it reaches the end.

NOTE: changing Selection or List modes will stop a clip if one is playing.

4.3.1.4 DDR PLAYBACK CONTROL

To the right of the **DDR** playlist is the **Playback Control** panel. This important section provides controls to **Play**, **Pause**, **Stop**, and most importantly, **Cue** the DDR to auto-roll videos as they're needed.

HINT: a diminutive version of the most important of these is also located under the small DDR preview monitors above, permitting you to control a DDR without actually opening the main DDR tab.

The time display at the top indicates either the selection or the playlist total run-time depending on your **Selection/List** setting above) under **Playback Mode.**)

If you click on the time counter while **Play** is stopped, you can change this to reflect the time *remaining* -- perfect for indicating a countdown to your presenter.



Figure 72

The transport controls provided include **Fast Forward**, **Stop** and **Rewind** (affecting either the entire list or just a single clip, depending which mode is selected.)

*HINT: Clicking **Stop** a second time jumps to the first frame of the selected clip if clicked a second time. If in **List** mode, **Stop** will jump to the beginning of the first clip. **Loop** will continue to play an entire sequence of clips in **List** mode, and will repeat a single clip in **Selection** mode.*

4.3.1.5 J, K, L HOTKEY CONTROL

The keyboard shortcut, k, will also play the **DDR** playlist (to be precise, the k shortcut toggles **Play/Pause**.) Pressing the neighboring speeds up the current rate of play – pressing it again speeds it up even more. Conversely, pressing the j key slows down the current rate of play; depending on the current rate of play, it will even reverse playback. Pressed repeatedly, the j key produces fast reverse playback (Appendix B – Keyboard Shortcuts) for the full list of hotkeys available.)

HINT: The blue LED ‘lights’ below the jog wheel show the current speed, whether forward or reverse. Click directly on one of these LEDs to jump to that speed increment!

4.3.1.6 TRICASTER PRO - PICTURE PLAYBACK CONTROL



The **Playback Control** section for the PRO version **Picture** module provides additional features.

These are somewhat similar to the DDR controls, discussed previously. differing only in one convenient respect:

The space occupied by the DDR’s shuttle wheel is given over instead to a pair of buttons labeled **+/- 1 Second**. Each click on either button changes the play duration of the current playlist selection by the one second.

4.4 TEXT

When producing newscasts, presentations and videos, it's essential to identify speakers and to present key facts both visually and verbally. TriCaster provides several methods of quickly creating great looking text and CG pages for live and/or edited projects. As this chapter focuses on **LIVE Production**, we'll discuss the **Text** panel tab nested in that main section first.

The **Text** panel features an easy-to-use template-based system. This lets you quickly call up and modify professional looking titles on the fly, adding your own customized graphics and logos.

Text Templates are provided in lower third as well numerous full-screen page styles. Template menus list the available entries by **Template Theme**, allowing you to easily locate templates having a similar graphic style. This is useful with developing a "look" for you program.

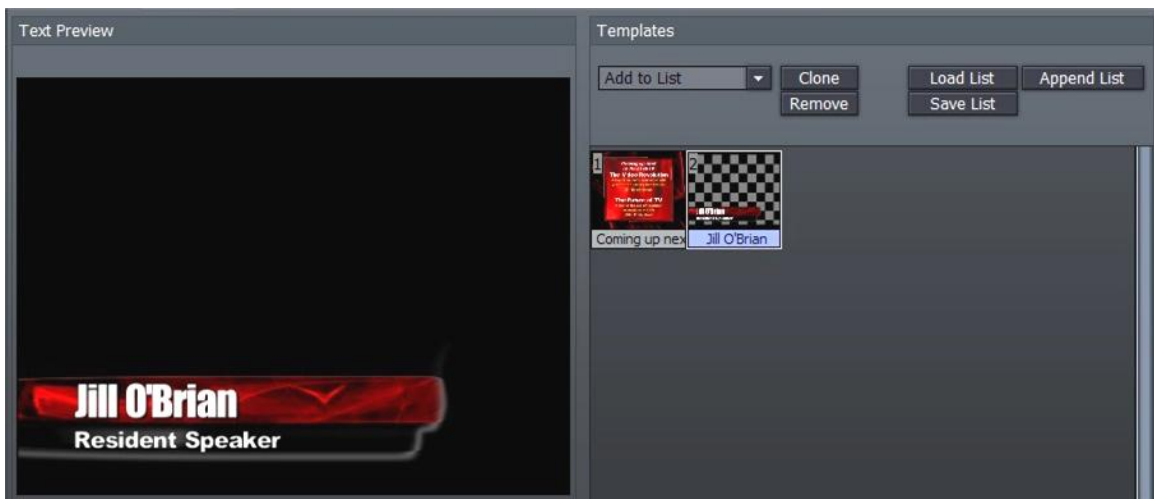

Figure 73 – Text tab

The Text panel is divided into two halves – a **Preview** (and Edit) pane at left, and the **Playlist** section at right.

4.4.1.1 THE PLAYLIST

The Playlist section contains an **Add to List** drop-down menu. Click in it to display a long list of available templates.

As you run the cursor over the list, a thumbnail for the entry is displayed (use the scrollbar at right to see more templates.) Click an entry to add it to the playlist area below.

Once you add a page, click on its thumbnail icon in the playlist to view it in the Overlay and Edit window at left. (When multiple files are selected, the page in the edit window will have a highlighted name in playlist.)

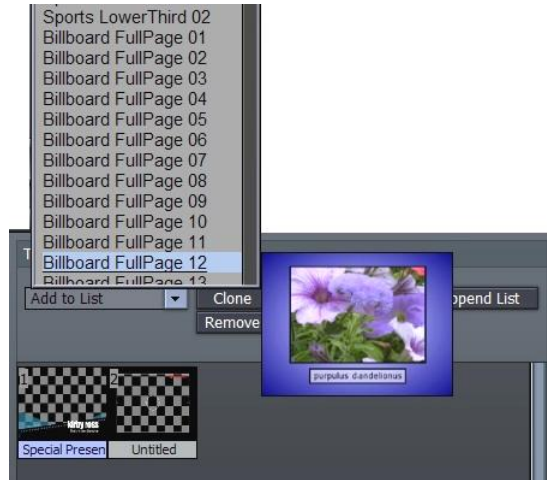

Figure 74

4.4.1.2 WORKING WITH TEMPLATES

To edit the selected Text page, click on a line of text (in the Preview pane) to present a text entry field; then replace the current text with your own. When the principle line of text or primary title is updated, the page name automatically updates in the Overlay Playlist. This makes it easier to quickly choose a specific page to display.

NOTE: text in the templates is pre-formatted and pre-sized, so be careful text you enter is not cut off for some title pages.

Often you will wish to use a consistent style for numerous pages. Load the template page once, click the **Clone** button (above the playlist) as many times as required, then modify the clones.

*HINT: Double-clicking a page in the **Text** playlist promotes it to the **Overlay** window, where it awaits display on Live output. You can use the previous/next gadget to the right of the Overlay window if your pages are already sequenced in the Text playlist.*

4.4.1.3 CUSTOM TEMPLATES

To modify a template using your own logo or imagery, you can choose from templates prepared for that purpose – a series of these are found in the **Insert Image** Template Theme group. Click on the template image in the Preview window, and a file window pops up - navigate to the image file you wish to use, and it will replace the default one. There is also a convenient “**Add Image ...**” entry at the top of the list.

NOTE: The inserted imagery can be created in any image-editing software (such as Aura or Photoshop™) that supports alpha channel transparency. This would include targa, tiff, gif, or png files where there is only the logo without a background layer. Add as many of these customized templates as you wish to your Overlay playlist.

Information on creating custom templates in Edit Text can be found later in this manual in Section 7.2.2.1, Export Options.

4.4.1.4 LOAD, SAVE AND APPEND

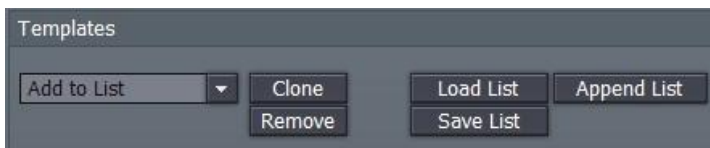

Figure 75

A list of modified pages you have prepared stored by clicking **Save List** -- save it with a name descriptive of the project. TriCaster defaults to its own **Playlists** folder, but you can save this file anywhere on the system. Load a playlist by clicking on **Load List** and navigating to the folder where you saved the file. **Append List** will append the current pages in the playlist pane to a previously saved playlist that you choose in the file requestor window.

4.5 COLOR BACKGROUND

For quickly creating colored backgrounds, TriCaster includes a digital background generator. In addition to designing your background, this tool is also capable of quickly saving and recalling up to 10 custom backgrounds. The Color Background tab is where you will find these features.

Along the left side of the **Background** tab are the 4 types of backgrounds you can generate. **Solid** uses one color across the screen, **Horizontal** uses two colors in a smooth gradient applied from left to right, **Vertical** creates a smooth gradient between top and bottom, and **4 Corner** allows you to choose distinct colors for each corner, averaging values toward the center.

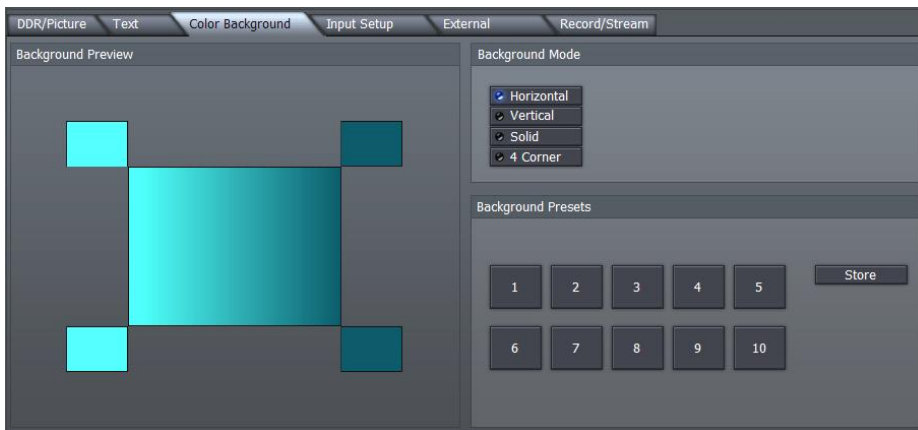

Figure 76

To create a background, click on a type -- say, **Horizontal**. Click on the upper-left square outside the background monitor to launch the **Color Picker** and select a color. This will be your left color. Now click on the upper-right square to choose another color. Once the background is just the way you like it, save it by clicking on the **Store** button -- select one of the 10 preset buttons, and you can recall it later with a single click.

Hint: The 4 color types also dynamically store the last color selection, so it is possible to have 14 combinations ready for use.

You can also right-click on a square, and (keeping the mouse button depressed), drag the mouse outside the panel to any other part of the interface. The mouse pointer becomes an eyedropper, ready to pick up the color underneath it when you finally release it.

It is helpful to know that the color in the box updates in realtime as you drag, allowing you to preview the result before committing to it. You can also use this ability to select a color from one of TriCaster's video monitors, permitting an exact color match to subject matter in a clip.

HINT: One of the principal uses of these backgrounds is to provide color behind text, keyed images, or for Effects.

4.6 INPUT SETUP



Figure 77 - Input Setup (TriCaster version depicted)

TriCaster dramatically simplifies the ability to input live cameras into your production.

All connected cameras (and other source inputs as well) can be pre-adjusted in a number of very useful ways. They are already configured just as you wish when you need to display them.

4.6.1 INPUT SELECTION

Use the **Input** drop-down menu to select which of the many sources available to TriCaster you wish to adjust.

If the **Follow Preview** switch is enabled (blue LED illuminated), the current **Input** selection will automatically update whenever you assign a new source on the **Preview** row of the **Switcher**. This is a convenient way to quickly address any adjustments you wish to make on the fly during a live presentation.

*NOTE: Certain parts of the **Input Setup** pane may be ghosted when they are not relevant to the type of source selected at the moment. For example, the **Proc Amp** controls are relevant only to live video sources, and will be inaccessible when you have selected **Ext**, **DDR** or **Picture** for setup.)*



Because TriCaster PRO, STUDIO and BROADCAST feature LiveSet™ technology, the Input Setup panel layout differs slightly.

For camera inputs (or other external analog source), select one of **Composite**, **Y/C (S-Video)**, **Y/C (BNC)**, **Component** or **SDI** for the **Type** (note connection options vary by model), according to the source type you have available (S-Video will produce a better-looking result than Composite; in turn Component is better still ... but SDI trumps them all!)

4.6.2 PROC AMP

Each camera (**Inputs 1-3**) can be selected in turn, and each has full processing amplifier (or 'Proc Amp') controls to make your image look its best. After selecting a specific **Input**, you can then refine how the camera looks on screen. (The proc amp can also serve to help you to balance the signal from dissimilar cameras so they match reasonably well.)

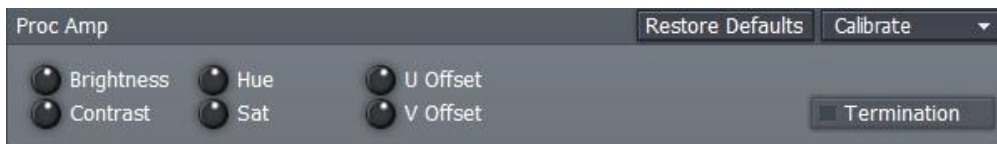

Figure 78

There are four basic camera adjustments in TriCaster – **Brightness, Contrast, Hue** and **Saturation**. The first two are familiar to all of us. **Hue** adjusts the master color of the video signal from the attached source, swinging the entire image through the color wheel’s spectrum.

Saturation is a reference to the intensity of the color. Zero saturation produces a black and white picture; increased saturation results in richer colors. However the nature of video display and standards is such that over-saturation can quickly result in ‘illegal’ video signal values. The latter manifest themselves in all sorts of nasty ways, including smearing and ‘crawling’ colors, and even audio issues – so be conservative when raising Saturation. Your TriCaster system provides **Waveform/Vectorscope** monitors, an invaluable way to accurately monitor the video signal to avoid this sort of issue.

All control knobs decrease value when you drag the cursor to the left over them, and increase when you drag to the right. Double-click a knob to restore the default setting for that one parameter. Clicking **Restore Defaults** clears all of your adjustments, resetting the currently selected input to factory default values.

*HINT: All control knobs in TriCaster have a specified response to the mouse, but when you wish to make very fine adjustments, hold down the **Ctrl** key before turning a knob. Rotation of the knob relative to mouse movement is then reduced by a factor of ten for much greater precision.*

The **U and V Offset** knobs are specific to Component and Y/C input sources:

- The U portion of the signal carries the blue and green color information. When you adjust the U Offset, you adjust only the blue/yellow portion of the video signal. Rotate U Offset clockwise to shift the signal toward blue, and counterclockwise to shift the signal toward yellow.
- The V portion of the signal carries the red and green color information. Adjusting affect only the red/green portion of the video signal. Rotate V Offset clockwise to shift the signal toward red, and counterclockwise to shift the signal toward green.

4.6.2.1 CALIBRATION

TriCaster’s **Calibrate** menu eases the proper calibration of preview inputs.

If you are adjusting a camera, feed a color bar test signal via the camera selected on the Preview row, then select either the **75%** or

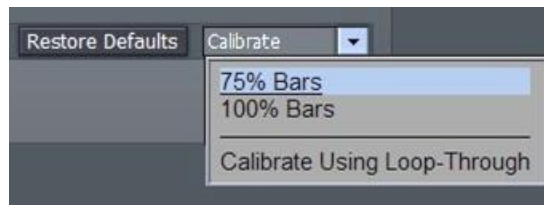

Figure 79

100% Bars entry in the menu (in NTSC regions 75% color bars are the norm, while non-NTSC regions generally rely on 100% bars.)

NOTE: It is important that this SMPTE color bar signal contains a pluge (“Picture Line-Up Generation Equipment”) section – a three-barred black section beneath the larger red bar) for proper reference.

When you select either **75%** or **100% Bars**, TriCaster adjusts all the Proc Amp controls to bring the signal into alignment. Of course, you should judge for yourself if the new settings look just right. If you are calibrating a video deck, play a tape with color bars on the deck and select the deck’s input as the source for the Proc Amp.

Calibrate Using Loop-Through, found in the Calibrate menu, is a shortcut to correcting all inputs simultaneously. It uses the values obtained from the initial calibration of a single input, and repeats them for all other similar inputs. (So, the adjustments derived by selecting one composite input and calibrating it can be repeated to all other composite inputs in the system, etc.)

As mentioned above, TriCaster also brings precise signal monitoring with a field-accurate **Waveform** monitor for monitoring both luminance and chrominance (Y/C), or to quickly check just the brightness (Y). The **Vectorscope** helps to align each color bar in the proper graticule box.

HINT: TriCaster also provides a color bars image in the Pictures folder – supplying it in a DDRs as a ‘regulation’ display can make downstream color phase calibration easier, useful if you plan to integrate the output of your TriCaster with other video sources using external equipment.

4.7 LIVEMATTE

LiveMatte is TriCaster’s powerful realtime keying system for live production. Keying has proved a popular and powerful method of combining or superimposing two images — whether still images, video clips or live camera shots. The process involves revealing the background image by eliminating a portion of the foreground image (effectively cutting a digital ‘keyhole’ in it.)

There are two popular means for determining what part of the foreground image will be treated as transparent, and they are referred to as ‘lumakeying or ‘chromakeying.’ The first is based on the foreground’s brightness (luminance) values, while the second depends on the color (chrominance) values.



Figure 80

For anything other than titling, chromakeying is the more common method in use today. When keying in video and film, for example, the foreground footage is often shot in front of a blue or a green screen. (When you see a television meteorologist in front of a weather map, that person is actually just standing in front of a blue or green screen. The colored background is chromakeyed to expose the computer-generated background map.)

Basic **LiveMatte** effects are configured in a dedicated section of the **Input Setup** panel (several special LiveMatte options are presented via the LiveSet section, and will be discussed in that context a bit later.)

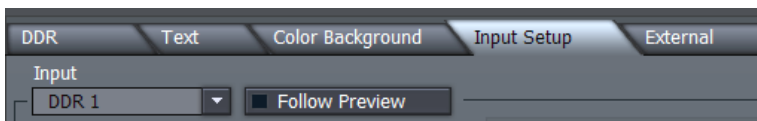

Figure 81

First, you need to assign the source for the LiveMatte effect using the **Input Setup** panel's drop-down **Input** menu, whether a live camera input, a clip in a **DDR**, or even the display from another computer on the network using **IVGA**.

When the **Follow Preview** switch is enabled (the default configuration,) the primary source for the effect is the one selected on the Switcher's **Preview** row. (This is useful as it allows you to set up the effect out of view.) Of course you can disable this default, and use the menu to select any suitable source.

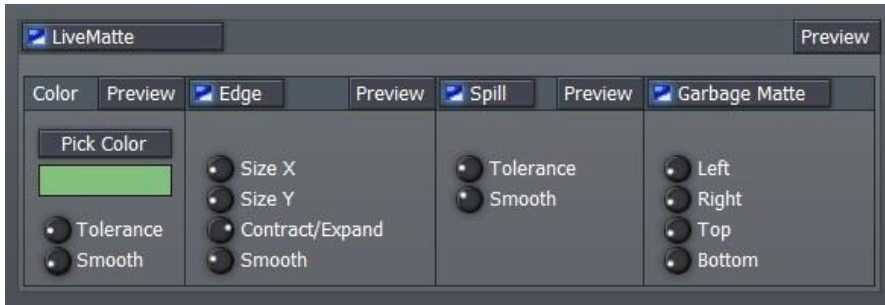

Figure 82

The next thing to do is pick the “key color.” We’ll focus on chromakeying first as this is the default LiveMatte operation (lumakey effects fall under the options available from the LiveSet panel, discussed later.)



Chromakeying removes a specific color from the foreground image. This color is chosen using the **Pick Color** button and the associated rectangular ‘color well’ beneath it. To choose a key color, right-click on the color well and - keeping the mouse button depressed - drag the eyedropper tool above one of the monitors to choose the color you wish to remove; then release (or, you can click the **Pick Color** button and do the same thing.)

NOTE: You could use the popup Color Picker panel by left-clicking the color well, but it’s usually simpler to get it right by choosing the color directly from the screen.

Figure 83

Besides choosing the type of key or the color, the **LiveMatte** section provides settings to fine-tune your matte:

Tolerance determines the range of luminance or colors to include as transparent. A low tolerance removes values close to the one chosen; as you raise the tolerance, you extend the range of values on either side of the actual color you chose.

Smoothness helps to remove the sharp edges in the key, softening the blend between the remaining foreground and new background imagery. Low values work best, because too much smoothing causes the keyed layer to become transparent.



Figure 84

The **Edge** controls allow you to explicitly refine the boundary zone at the edge of the matte. The **Edge** button is a toggle, either enabling or disabling the settings beneath.

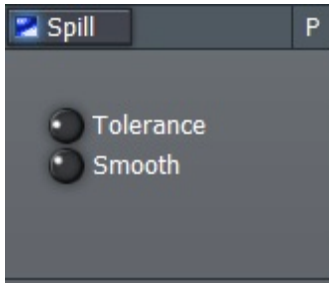

Figure 85

expansion and contraction.

The term **Spill** refers to key color unintentionally reflected or 'spilled' onto the foreground subject. It's not unusual for a little green spill to occur on the shoulders of a person in a greenscreen shot, for example.

The **Spill** controls, when enabled, remove key color spill in Chromakeys by lowering the saturation of that color in the foreground, where it doesn't belong. The net result is that it is eliminated, or at least reduced to the point where it is not objectionable.



Figure 86

The **Contract/Expand** knob fine-tunes the key by allowing you to carefully contract or expand the matte, which is very helpful in removing artifacts in compressed video. Contracting too much can erode fine detail, such as wispy hair – but expanding too much can result in the key color reappearing in places. **Size X** and **Y** provide

independent control over vertical and horizontal

*When your TriCaster model features the added **Effects** row on the Switcher, the source you wish to supply the **background** for your LiveMatte composition should be selected there.*

*Otherwise – for systems with a two row Switcher – whatever source you place on **Preview** after you switch your (LiveMatte enabled) source to **Main** will supply the background.*

When keying techniques are employed, it's not unusual to find unwanted inclusions in the background. The offending items might be lighting or other set hardware, or something as simple as a wrinkle in the greenscreen.

The **Garbage Matte** label owes its name to techniques used to remove such unwanted 'garbage' from the scene.

Left, Right, Top and Bottom knobs control ‘matte cropping’, and can ‘tighten in on’ the foreground subject, eliminating various problems of this sort.

HINT: The best method for optimizing the key is to begin with the best incoming source possible; if your cameras have both composite and S-video outputs, check to see which one gives you the best picture quality.

Rotate all four knobs fully to the left (off) and adjust first Tolerance, then Edge settings, Smoothness, and lastly Spill.

4.8 LIVESET



Selected members of the TriCaster family provide the amazing LiveSet™ virtual set technology.

Like most super heroes, TriCaster’s **LiveSet** panel hides its superpowers behind a mild-mannered and unobtrusive exterior!

Don’t be fooled by this apparent simplicity. This panel may be small, but it holds ability that outstrips systems costing many times the price of your TriCaster and your automobile put together!

4.8.1 UTILITIES – MATTE OPTIONS

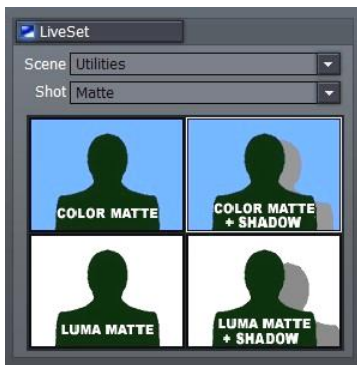

Before getting into a full discussion of the ability **LiveSet** brings to your system, let’s complete our discussion of **LiveMatte** effects by covering keying options located here!

LiveSet’s drop-down **Scene** menu is our first stop. Set that to **Utilities**. Next, use the **Shot** menu to select the **Matte** entry (the **Matte Blur** selection operates similarly, but provide different levels of blurring to the background.) When you do so, the **interactive quad display** beneath these menus will display four options, as follows.

Figure 87

Click the **COLOR MATTE + SHADOW** thumbnail appearing in the pane below to add a foreground shadow to the **LiveMatte** effect you have already set up (LiveMatte must be enabled in its own panel as well.) Clicking **COLOR MATTE** restores the default color-based **LiveMatte** effect.

The **LUMA Matte** option invokes a **LiveMatte** effect based on brightness values, instead of color. For these cases, set the **LiveMatte** 'key color' well to either white or black, and then adjust the other controls and settings as discussed above. (LUMA MATTE is principally useful for situations requiring you to key title slates provided as white text on a black background. For most other purposes, COLOR MATTE will produce a better result.) LUMA MATTE + SHADOW is similar to the COLOR MATTE option above.

4.8.2 OTHER UTILITIES

The **Scene** menu item **Utilities** contains a diverse multitude of handy functions to enhance your live video stream. Flip your video, stretch or squash it, apply wild effects to it, letterbox it and change its aspect -- the sky is the limit here. Experiment to your heart's content, Spurn not the humble servants

Patiently waiting to do your bidding on a moment's notice (with nary a complaint or grievance to the shop steward), these effects can be lifesavers.

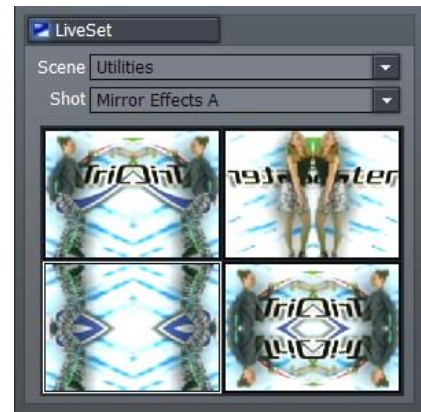

Figure 88

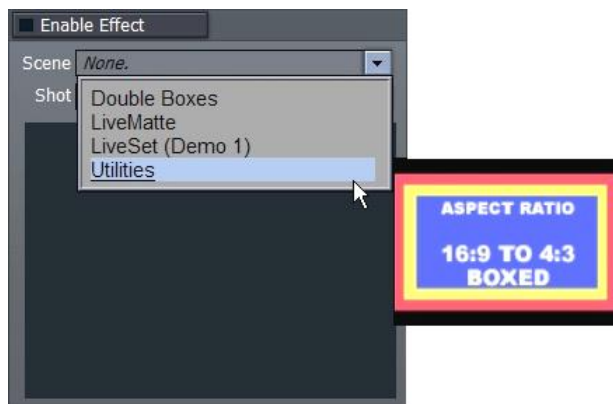

Figure 89

Suppose the boss absolutely *insists* you add that great widescreen clip from last year's summer vacation in Death Valley (the whole family spread out like parched lobsters in front of the Winnebago) to the gala presentation at the annual meeting.

"But Boss," you decry in vain – "that shot is HD, 16x9m, and this is a 4X3 production. I'll have to crop out Aunt Minnie on the left and cousin Doofus on the right, or you'll wind up looking like a 97-pound weakling in front of the entire membership of the board!"

Alas, the majestic one replies archly, “Don’t tell me your problems, Smedley! Just fix it, or I’ll fire you and find someone who can!”

Be not faint of heart -- **Utilities** to the rescue! Drop the hideous clip in one of TriCaster’s DDRs, select **Utilities** in the **Scene** menu, and **Aspect Ratio** as the **Shot** setting. Then, with a single click of the wondrous “16:9 to 4:3 Boxed” button in the interactive pane below, the whole family appears in cinematic splendor, perfectly sized (and sunburned to a crisp.)

You’re a hero! You get a promotion, parking spot, and invited along on next years’ trip.

4.8.3 LIVESET POWER!



We’ve barely scratched the surface of what LiveSet can do. The **Scene** menu reveals numerous other useful and varied options. New additions arrive regularly with product updates, but let’s consider a few of the entries it provides to get the idea.

Note as you scroll down the **Scene** listing, a convenient fly-out panel shows a thumbnail representation for each selection.

One item is **Double Boxes**. This Scene group permits you to place two of TriCaster’s video sources, (whether live cameras, iVGA displays, or DDR content) in side by side panels on the screen.

While these effects can loosely be classed as ‘picture-in-picture’ effects, they go far beyond the norm. Great looking 3D frames surround your

video, with gorgeous professional

backdrops. Experiment with these and you’ll quickly get the idea.

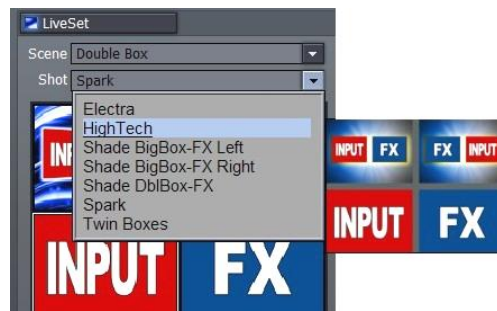

Figure 91



Figure 90

Many of TriCaster's **Effects** take two inputs, as in this case. The first **Input**, or primary source for any **Effect** is determined by your selection in the main **Input** menu of the **Input Setup** panel. When appropriate, the second video source is generally designated by the **Effects Row** selection in the **Switcher**.

The **Spark** set from the **Double Boxes** list is shown at right. Notice that when you select it, the previously blank panel beneath is activated.

This panel is much more than just an enlarged thumbnail or even a preview, however.



Figure 92

Again, this little quad panel provides four interactive options.

By clicking any one of the four squares, you determine how the effect will be applied. In this case (**Double Boxes**), you can swap the sources shown in the boxes by selecting one of the upper two quadrants; or fill the screen with either source with another click!

Note: when the quad thumbnails provide matching PIP and full screen alternatives, you can swap from one to the other live, even without using the Switcher!

4.8.4 MORE LIVESET



Figure 93

LiveSet may fall (slightly) short of miraculous, but it certainly comes within shouting distance. Even so, at risk of the suspense killing you, we're going to postpone further discussion of **LiveSet** here.

As tempting as it is to discuss **LiveSet** right now, it's so cool we decided to give it a chapter of its very own. If you really, really can't wait, we'll understand if you skip ahead to Chapter 8, LiveMatte, LiveSet, Live Action! For those with a little more self-control, however, here's a little teaser. 😊

(If you do decide to stay here with us, please be assured we'll keep you company all the way, and the wait will be rewarding.)

4.9 EXTERNAL

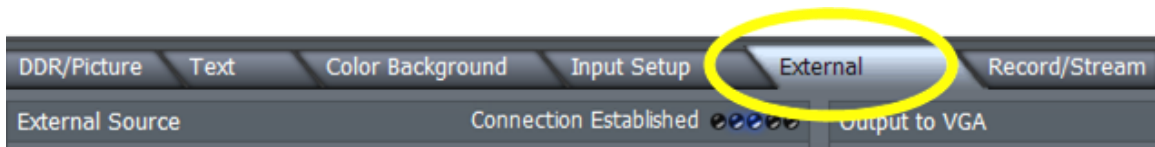

Figure 94

The main **External** tab provides the controls and options necessary to permit you to do something revolutionary. Among other things, several different and very useful external inputs can be selected as video sources in TriCaster's **LIVE Production** environment

Available external source include displays from network connected (Windows or OSX) computer systems (via iVGA), and text and graphics overlays from LiveText™

The active External source is available on the **Switcher**, and of course can be captured or streamed, as well.

Perhaps best of all, **External** sources can optionally be passed through the **Output to VGA** section at full 'computer desktop' resolutions, to supply high resolution display devices such as LCD projectors.

Note: Output to VGA does not degrade the original pristine (high resolution) source, as there is no need to first scale the source down to standard video resolution.



STUDIO and BROADCAST model TriCaster systems permit three external sources to be concurrently cued up, ready for instant selection as the active Ext source.

4.9.1 USING iVGA

For an iVGA source to be recognized by your TriCaster as an External Source, you must first install a small iVGA client program a computer on your network. iVGA client programs are supplied for Windows 2000, Windows XP or Mac OS X. You will find the iVGA installation files in the C:\Tricaster\TriCaster iVGA folder.

IVGA FOR OS X™

The iVGA installation for Apple OS X® system is supplied as a zipped disk image (.dmg) file. To install it, first establish a network connection between your Mac and TriCaster systems. Then copy this file to your Mac desktop.



Figure 95 – mounting the iVGA disk image

Double-click the Zip file to decompress it, and then double-click the .dmg file to mount it. The NewTek iVGA icon shown above will be placed on your Desktop. Open it (by double-clicking, and you will see two files in a Finder window – the readme file, and the iVGA client program.



Figure 96 – iVGA Disk Image content

Drag the iVGA icon from the finder to your Applications folder.

Run it by double-clicking the icon, and in a moment or two the iVGA swirl will be placed in your Dock, and an onscreen dialog reporting 'iVGA Ready and listening!'

The new source (your Mac screen) will be listed for selection in your TriCaster's External Sources menu!

When iVGA is running, the icon in the Dock has a menu you can access by right-clicking on it:

1. Engaging **Privacy Mode** prevents the client display from appearing accidentally on the TriCaster display when you don't want it to.
2. You can set iVGA to show either of two monitors, when you have more than one attached.
3. **Open at Login** will automatically launch iVGA for you every time you login, if you wish.



Figure 97

IVGA FOR WINDOWS®

The iVGA installation for Microsoft Windows® systems is supplied as an executable (program) file. To install it, first establish a network connection between the Windows client system and the TriCaster. Then copy this file to the client system.

iVGA will run from anywhere you put it on the client hard drive, but you might wish to install it in the Program Files folder - or Program Files (x86) under a Vista® 64bit version of Windows.

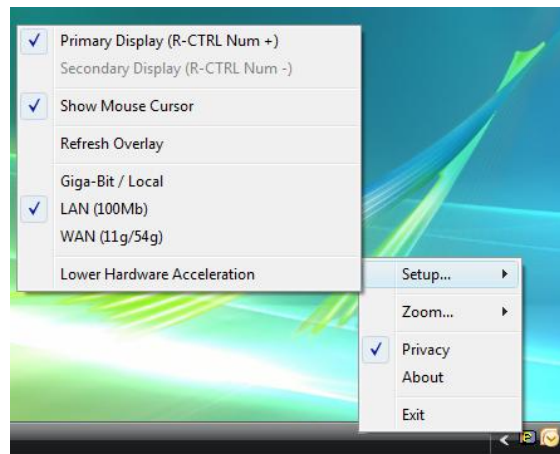

Figure 98 – iVGA context menu, Windows® version

Run iVGA on the client computer by double-clicking its icon. A smaller icon will be added to it's the Windows task tray. When this computer is set in TriCaster's External Source panel as the active source, the iVGA icon begins cycling -- alerting the operator this is a live input.

Right-clicking the little icon reveals a menu with various iVGA options (Figure 98):

1. **Setup** allows you to choose between monitors on a dual-screen system. You can also decide whether or not to **Show Mouse Cursor** in the display.

Refresh Overlay is there in case you need to quickly reset iVGA. Selecting this is equivalent to stopping and re-starting iVGA.

This is also where you set the rate of transfer your network can safely handle:

- **Giga-Bit/Local** network type provides the best transfer rates.

- A standard LAN (**100 Mb**) Ethernet connection (or crossover cable) would usually outperform wireless networking (**WAN**).

- Slower connections may drop frames (even In extreme cases, where network capability is low or unreliable because of other traffic iVGA would still be useful for static displays.)

Lower Hardware Acceleration may help in some cases where a client application uses display technology that would otherwise not work with iVGA. (Normally this can be left disabled.)

2. **Zoom** allows you to magnify an area of the Windows display, which can help when fine detail is important for an application display on the screen. The portion of the screen sent to iVGA output is determined by the position of the cursor on screen. You can set zoom to 150, 200 or 400 percent, or disable it. When you do not want your zoomed view to move once set, you can lock zoom position with a hotkey — Right Ctrl + Numpad 9. The hotkey is a toggle – use it again to cause the display to track the cursor again (this is useful to re-position the display, too.)
3. **Privacy** mode allows the client some discretion if they need to check e-mail, or perhaps view or arrange something without risk of the audience observing. When selected, this will display

a large “Privacy Mode” banner in TriCaster’s preview monitors, so the operator is aware this source is temporarily off-line. The client icon also has a ‘P’ across the face, to remind the client that privacy mode is active.

4. Lastly, selecting **Exit** shuts down the iVGA client, and removes the icon from the task tray.

4.9.2 USING LIVETEXT



Figure 99 – LiveText LIVE Output pane

As we noted in the Quickstart chapter, at Section 3.2.4.2 (LiveText™), a workstation on your TriCaster network with LiveText installed serves as a dedicated CG and Title solution for your TriCaster presentations.

When running and connected, LiveSet will be listed in the External Source menu, similar to an iVGA source.

For more information on installing and using LiveText, please refer to its manual.

4.9.3 EXTERNAL SOURCE

The left half of the External tab is home to the **External Source** panel. This is where you can select from available external sources.

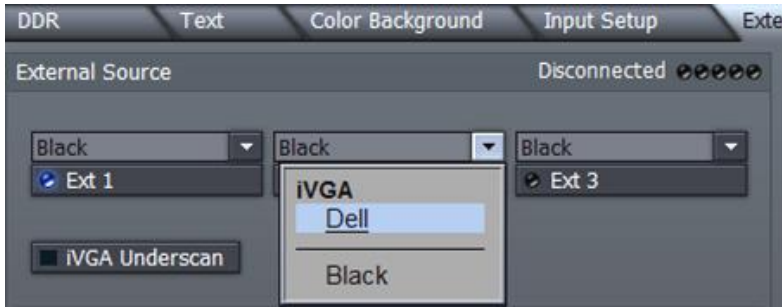

Figure 100 - STUDIO and BROADCAST versions feature three External selections

Once launched, the **iVGA** client and **LiveText** publish their availability across the network to the host TriCaster system. TriCaster then adds the external source to the list of potential live inputs in the External Source drop-down menu(s), making them available for selection.

Once the External Source is selected, simply click the **Ext** button to activate it on any of TriCaster’s Switcher rows.

NOTE: when you only need to connect to a single, nearby computer, you do not need an elaborate network. Use the supplied network crossover cable for direct connection between TriCaster and any external computer.

(When you connect any computer to a network, after about one minute, TriCaster will generate its own unique I.P. address. If a **DHCP server** comes online afterward, that computer will be generated as a new address from the server. The good news is that if you give it a moment, TriCaster should find all clients on the network, listed by their computer name.)

NOTE: As with networking in general, it is imperative that each computer on the network have a unique name. If there are two computers named ‘Calypto’ running the client, there is no guarantee TriCaster can select the one you want.

The active External source is also listed (as Ext) in the Input drop-down menu of the Input Setup tab. This means it can be treated like any other video source, including the application of keying or other Effect (the Proc Amp tools are not available for an External source, however.)

4.9.4 iVGA OVERLAY

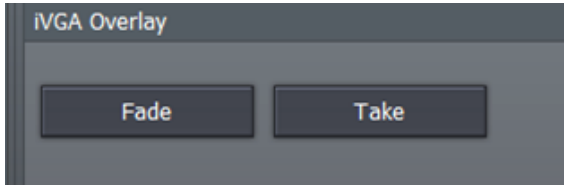

Figure 101

The **iVGA Overlay** panel (beneath the iVGA input setup menus) contains only two buttons, **Fade** and **Take**. These behave in identical fashion to the buttons by the same name in the main **Overlay** panel, with one exception:

Clicking either of these buttons does not overlay the current iVGA source on TriCaster's **LIVE Output**, as the normal Overlay does:

All sources running through the primary **Switcher** or **Overlay** are at standard video resolutions; the same thing is true if you bring an iVGA source into the production through the Switcher. Any computer (iVGA) display used in this manner *must* be scaled down to be acceptable to standard devices connected to TriCaster video outputs.

However -- the **iVGA Overlay** function does not appear on the *normal* video output. It is overlaid only on the signal going to the (higher resolution) rear **DVI connector**, which port is provided to feed high resolution projection and display devices.

This makes it possible to supply this output path with a mixture of lower resolution video signals *and* a higher resolution computer display, without degrading the latter! TriCaster can pass any supported screen resolution from XGA (1024x768) up to Super Quad XGA (2560x2048).

HINT: ESC is the VGA Take hotkey, and Shift-ESC is the VGA Fade hotkey.

NOTE: if a monitor or projector is not detected on the DVI connector, the relevant sections of TriCaster's control panels will be ghosted (unavailable). You must connect a second output, and then re-start the system. Once it has re-started, these controls will be activated.

4.9.5 OUTPUT TO VGA

The right half of the VGA tabbed panel Output is taken up by the **Output to VGA** pane, which has three sections of its own.

Note: a LiveText™ source is available - when activated as an External Source - to the Switcher and Overlay sections, but not for Output to VGA.

4.9.6 RESOLUTION

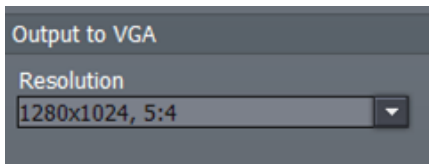

Uppermost is the **Resolution** menu, which permits you to set a resolution appropriate to your connected high resolution display device. Ideally, use the largest size supported by your external display device.

Figure 102

4.9.7 VGA KEYING



Figure 103

Beneath this is the **Keying** section. This is a simplified version of the main keyer discussed earlier. Computer displays are normally composed of substantially less complex color combinations than video, making them an easy candidate for keying.

The **Custom** option, when enabled, is essentially a chromakeyer. It provides the same basic color well as the latter. Right-click in the color selector, and - holding down the right mouse button - drag the eyedropper to the monitor, releasing it above the color you wish to make transparent.

The **Black and White** buttons are simple Lumakeyer alternatives – click the appropriate choice to make either black or white areas transparent. For example, to display song lyrics, you might wish to key white text over another video source.

HINT: A high resolution iVGA source keyed in this fashion can provide sharper text on display devices connected to the DVI port than lower resolution overlays fed through the switcher or primary Overlay section.

Whichever keying option you select, **Tolerance** determines the range of luminance or color to include as transparent. A low tolerance removes values close to the one chosen, while increased tolerance includes a broader range. The Smooth setting helps to remove sharp, pixelated edges in the key.

4.9.7.1 POSITIONING

Towards the lower right section of the **External** tab is the **Positioning** panel. Located here are several additional controls to perfect your high resolution DVI output. *Keep in mind that the controls in this section affect everything displayed on the DVI port – not just iVGA sources.*

First are controls to properly center the display. **X Pos** adjusts the screen’s horizontal position, with negative values shifting the image left, and positive values shifting the image to the right. As you would expect, **Y Pos** controls the screen’s vertical centering.



Figure 104 – (note: Video Enhance not on all models)

Crop Top, Bottom, Left and Right trim the screen edges. The values are expressed in pixels.

HINT: Crop can be very useful to eliminate rough edges from standard video source. These are not normally seen on a television, where they appear behind the screen's bezel - but they are clearly apparent on a projector.

There is also a simple **Proc Amp** section to help you optimize the output display. The **Brightness** and **Contrast** knobs are self-explanatory, while **Video Enhance** can be thought of as a “sharpness” control (Video Enhance is featured on selected models only.)

4.10 RECORD OR STREAM

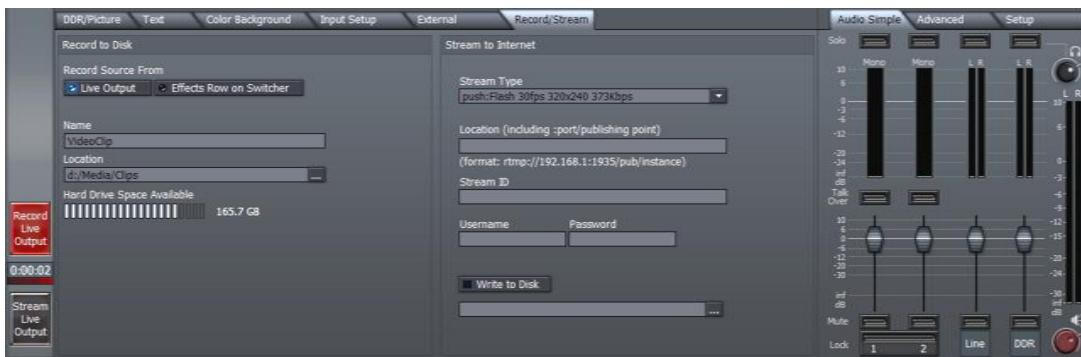

Figure 105

TriCaster offers producers the ability to send live output to hard disk for archiving and later editing, or send it out as a live Internet stream (using either Microsoft Windows Media™ or Adobe Flash® encoding.) The settings and controls for these operations are grouped in the **Record/Stream** panel, accessed by clicking the main tab with that label.

You can even record video to disk and stream at the same time! (The captured file can also be uploaded to your streaming provider for on-demand streaming *after* the event.) Further, your live output can always be recorded externally by a video deck or DVD recorder at any time.

See Chapter10, Streaming, Networking and the Internet for more detail on streaming.

4.10.1 RECORD OPTIONS

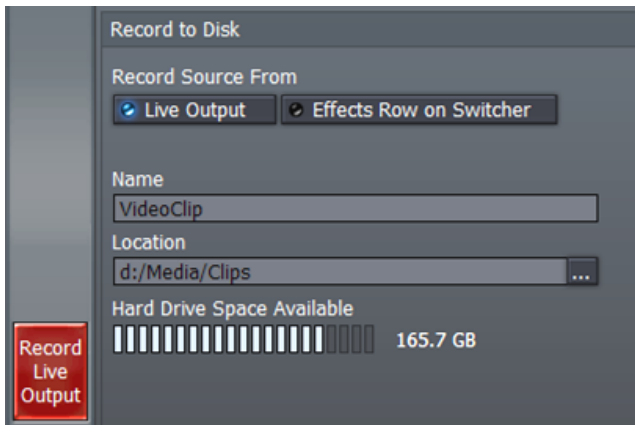

Figure 106 – PRO, STUDIO, BROADCAST with Record Source option

Selected models permit you to record either the main **Live Output** or Effects row stream.

Click the **Record Output** button at far left, to capture the selected a/v source to your hard drive. (**Live Output** includes cameras, clips played back from DDRs (and Picture), LiveSet effects, External sources and Overlays, while **Effects** captured only that row's output.)

Hint: the Record button is Red when recording Live Output, and blue for Effects!

A hard drive capacity monitor shows your remaining storage space, and a counter below the Record Output button keeps track of the length of your current recording.

4.10.1.1 RECORDED FILES

TriCaster records in a high quality 'platform agnostic' MPEG-2 file format. You will not usually have any problem viewing or loading these files into software on other computers. Later editions of Windows® and

When you need to perform a live switching session, and capture this for later DVD duplication or editing you will use the **Record to Disk** section, which comprises the left-hand section of the **Record/Stream** tab.

First, enter a filename for in the **Name** field. Then decide where you wish the video clip to saved, using the **Location** section of the panel.

Click the [...] button to pop up the familiar TriCaster file panel, which you can use to navigate to a convenient place on the "D:" drive, or a suitable external drive you supply.

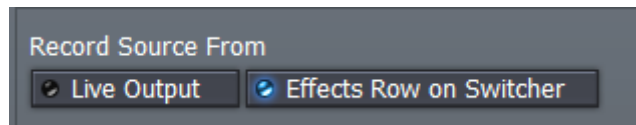

Figure 107 – PRO, STUDIO, BROADCAST with Record Source option

OS X® handle them just fine, and third-party DVD viewing and authoring software usually installs suitable a codec too.

Occasionally, a system running an older version of Windows may lack an appropriate codec. In such a case, scouting around on the Internet is likely to turn up a (free or inexpensive) MPEG-2 one (just search for something like “Windows play mpeg-2”.)

4.10.2 LIVE STREAMING

When you need to stream your TriCaster output to the Internet, NewTek has made this process as simple as possible. In addition to the standard Windows Media Streaming Profiles, TriCaster allows you to stream using Windows Media 11 and VC1 presets, as well as Flash.

Note: VC1 is the video standard for HD DVD and Blu-ray Disc players, as well as being used in some other environments, including gaming applications.

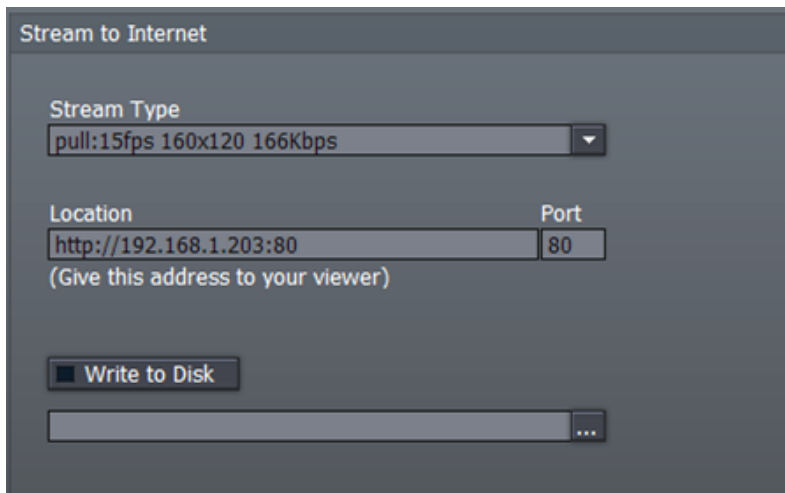
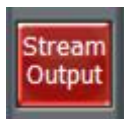

Figure 108



The **Stream to Internet** panel is neighbor to Record to Disk in the **Record/Stream** panel. At the simplest level, with TriCaster connected to the Internet, all you really need to do (to establish an outgoing a/v stream) is click the **Stream Output** button!

Figure 109

Enabling TriCaster’s outbound stream immediately provides you with the IP (Internet Protocol) address of your computer on the network. This information will be provided as ‘punctuated’ numeric value in the **Location** display field, shown here.

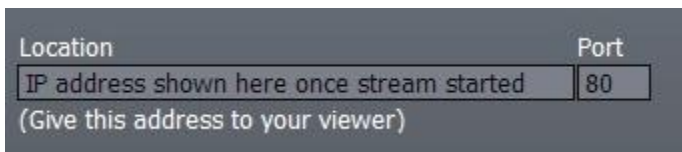

Figure 110

You can provide any clients or streaming providers this mms: (Microsoft Media Server) address. Entering this into the File menu of Windows Media Player (using copy, and pasting it into the Open URL window) will direct **WMP** to show the stream from your system on client computer system(s) connected to the Internet.

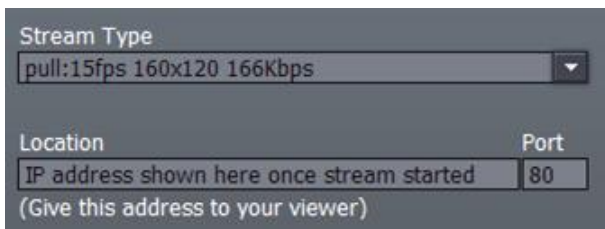

Figure 111

The Stream Type drop-down menu allows you to select various image sizes and bandwidth rates for your Internet broadcast (and also provides other important option, including (Push or Pull) Windows media or Flash streaming.) The default Stream Type is a single Windows Media stream at one-half standard video resolution (360x240 pixels) - but you can modify this to suit your need and the capability of your Internet connection.

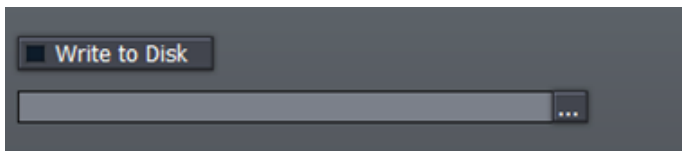

Figure 112

The **Write to Disk** option allows you to archive the live *stream* as file. Click the ellipsis (the [...] button) to choose where you wish TriCaster to save the resulting file.

*NOTE: If the **Write to Disk** option is chosen, it's important to remember to turn off the **Stream Output** button when the presentation concludes, or TriCaster will continue writing this file.*

4.11 AUDIO MIXER

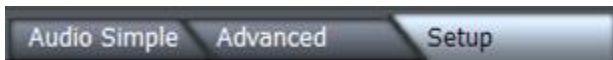

Figure 113 - PRO, STUDIO and BROADCAST version Mixer

TriCaster provides audio reinforcement and refinement of your Live Production presentation by means of its integral audio mixer. The mixer features either two or three tabbed panels, variously providing volume control and equalization for the external inputs and the stereo channels of internal DDRs, as well as advanced configuration options (in the Setup tab) for selected models.

4.11.1 BASIC AUDIO CONTROLS

We'll consider the Audio Mixer tabs separately. However, first let's look at some common features, then go on to discuss their unique aspects.

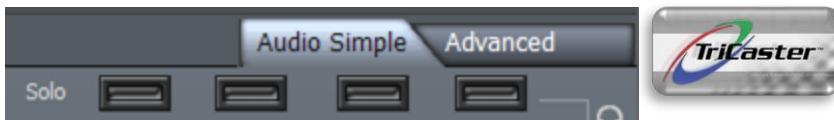

Figure 114

The top row (just below the tabs) for both the **Audio Simple** and **Advanced** tabs is similar for all models (although the number and type of audio sources shown varies.)

Here we find the **Solo** buttons for **Mic, Line, DDR, and AES** inputs (as befits your TriCaster model). When selected, the Solo buttons illuminate in green, and cut audio to all other inputs. The selected Solo channel(s) becomes the only audio output from TriCaster.

The lower halves of *both* the **Audio Simple** and **Advanced** tabs are also identical. The uppermost row of buttons is labeled **Talk Over**. This feature, available for all main input channels, allows a presenter to instantly give audio priority to one or both of the incoming microphones. Instead of muting, Talk over reduces the audio levels of everything else by 20 percent.

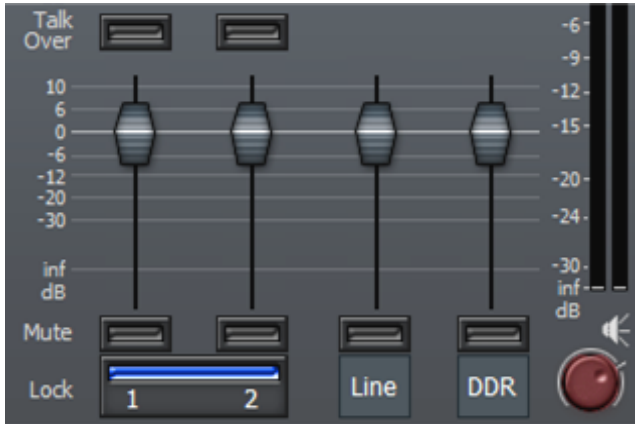

Figure 115 – TriCaster standard Audio Mixer

The most noticeable feature in this section is the large area devoted to individual volume sliders. Drag these up and down to adjust levels for the designated audio source, just as you would when using an external mixer.

The **Lock** buttons at the bottom illuminate in blue when enabled, and lock related sliders together. This is convenient when you are using the mono input channels as stereo pairs.

Mute buttons are supplied for each source channel, as well. These turn red when enabled, indicating the channel is temporarily disabled.

4.11.2 MONITORING AND MASTER CONTROL

Finally among features shared by all three main audio tabs, we note the long vertical column at the right that controls master output and headphone (monitoring).

The red volume knob below the two-channel VU meter display is the master output volume. This control governs the output level for all channels.

The volume knob at the top of the audio mixer provides separate control for TriCaster's headphone output, permitting the operator to comfortably monitor Live Output via the headphone connection on the front of your TriCaster.



Figure 116

4.11.3 AUDIO SIMPLE

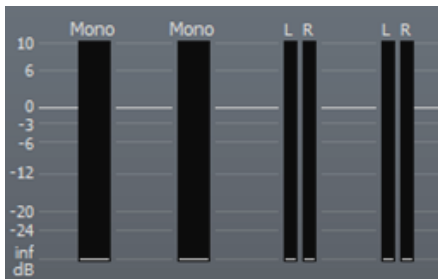

The only section of the audio simple tab we haven't touched on already is the **VU meter** panel, shown here. Large VU meter strips display the audio level for mono inputs, while thinner stereo pairs are provided for Line and DDR(s).

Figure 117

Optimal audio levels are in the -6 to 0dB range. These levels are indicated by a light blue bar in the VU meter. Higher levels are shown as light orange or red. If you notice audio going above 0, clipping is occurring. You should reduce that source's volume using the slider beneath.

4.11.4 ADVANCED

The **Advanced** tab reveals a three-band equalizer, along with **Pan** controls for each TriCaster audio channel.



Figure 118

Drag your cursor left or right above the **High, Mid and Low** knobs to increase or decrease the level for that part of the audio spectrum for a specific channel.

(As usual, double-clicking the knob returns it to the default setting, in this case centering the knob to result in no attenuation or gain for the selected band.)

HINT: Bear in mind that adjusting the relative level of part of the audio spectrum affects the level for that channel, and may call for compensating adjustments of the main level slider as well.

The **Pan** controls adjust the amount of sound from the designated source which will be placed on the **Left** or **Right** output channels. When centered, sound from a given channel is evenly split on both Left and Right outputs.

4.11.5 AUDIO SETUP



The final audio tab is **Setup**. This panel, found on selected models, provides **Mic** or **Line** level selection, permitting you to accommodate low-power microphones and full-power line level inputs.

When enabled, the **Phantom** button sends phantom power to microphones requiring it. As impedance variations can be encountered in the field even when dealing with professional audio equipment, a **Variable Gain** switch is also provided. Turning the nearby Trim knob clockwise allows you to specify a custom setting.

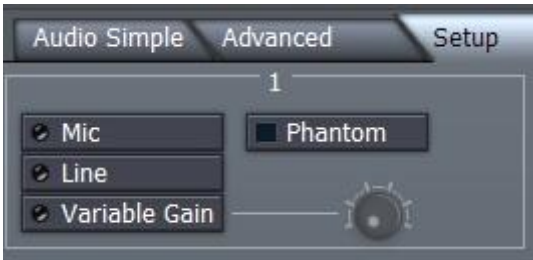

Figure 119

4.12 CONFIGURE PANEL (BROADCAST)



Figure 120



The TriCaster BROADCAST model uniquely features a additional configuration panel. The Configure panel provides control over some internal preferences settings of the BROADCAST system. To open it, click the **Configure** button at upper right (next to the clock display.)

The optional Configure panel lists a number of optional settings in a column at left. Each item listed has a corresponding a menu option or numeric slider in the right-hand column.

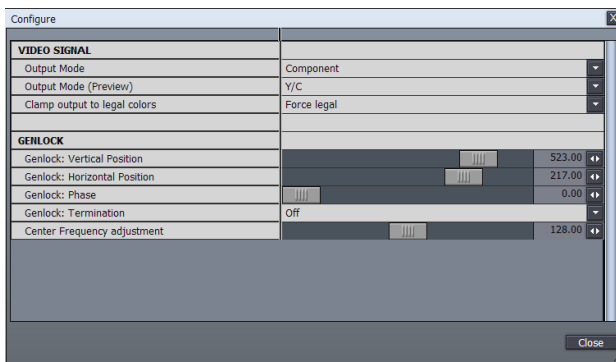

Figure 121

4.12.1 VIDEO SIGNAL

Output Mode:

Choose Component or Y/C for output mode.

Output Mode (Preview):

TriCaster BROADCAST supplies the source selected on the Preview row for connection to an external monitor. Use this to designate the connection type, Component or Y/C.

Clamp output to legal colors:

TriCaster is capable of retaining and working with certain colors that fall outside of the typical 0 - 100IRE luminance range (and similar Chroma ranges). Although this can be useful in the right hands, out-of-range chroma can exhibit problems on output to certain displays (especially visible in Y/C and composite video.)

If you run component then this effect does not happen, and you should be able to access the full gamut of possible colors.

The extra information is still useful and can be used in editing and color correction for a number of very useful things

Apart from the base model, all TriCasters provide waveform monitor and vectorscope modules to help you detect illegal video colors passing through the system. Signal levels for each input may be adjusted to acceptable tolerances using the Proc Amp controls in the Input Setup panel.

Still but you may prefer to simply enable 'clamping' instead (although the impact of clamping on the video signal may be discernible to a very discriminating eye.)

4.12.2 GENLOCK

"Genlock" is an abbreviation for generator locking device. Such devices serve to synchronize the signals from two or more video devices. The genlock accepts a reference signal (house sync) - such as a black burst signal - and locks other devices to the same frequency as the reference signal.

Note it is not required that you genlock TriCaster video sources, as internal sync is provided. However, doing can sometimes shave roughly one frame off transmission latency in an IMAG environment.

Termination:

In a situation where you intend to loop a house sync signal *through* the TriCaster BROADCAST to other devices, **Termination** should be turned off.

5 CAPTURE MEDIA

TriCaster allows you to capture video from live cameras, or other sources such as a VCR or DVD players. The captured files can be used in either live production or as part of an edited video project. This chapter examines your capture options.



Figure 122 – TriCaster STUDIO Capture tab

The **Preview Monitor** consumes the left upper half of the Capture Media screen. There are three other main regions on this workspace: **DV Camera** control and **Capture Details** fill the rest of the upper half of the screen, and the **Captured Files** bin consumes the entire lower half.

5.1 CAPTURE DETAILS

The **Capture Details** panel allows you to select which input source to record. You can choose any of the source types available on your TriCaster model.

Input Type	TriCaster	TriCaster PRO	TriCaster STUDIO	TriCaster STUDIO
DV	√	√	√	√
Composite	√	√	√	√
Y/C (S-Video)	√	√	√	
Y/C (BNC)		√	√	√
Component		√	√	√
SDI (Analog Audio)				√
SDI (AES Audio)				√
SDI (Embedded Audio)				√

Generally, for Capture purposes sources must be connected to Input 1 for a given input type.

Audio Input types likewise vary by TriCaster model. For recording narration or voice-overs (audio only), select **Mic 1 (Voice)** to record a .wav file directly to disk from first microphone input.



Figure 123 – BROADCAST Capture sources

When video sources are selected, you can choose to capture video and/or audio, using the switches provided in the **Streams to Capture** section. Selecting an Audio Only source, such as **Mic 1 (Voice)** or SDI 1 AES as the current capture source automatically deselects the **Video** stream switch.

The **Name** field allows you to type in a base name for your captured files. TriCaster will automatically increment all subsequent captured filenames numerically.

(So, if you set a file name of “MyCapture”, the subsequent clips you capture will be automatically named “MyCapture001”, “MyCapture002”, etc.)

Finally, the **Capture Details** pane shows a gauge to inform you how much free space remains on your TriCaster.

5.2 DV CAMERA CONTROL

DV Camera Control allows you to connect a standard definition Digital Video (DV) camera or deck to TriCaster using your choice of the 4 pin or 6-pin connections provided, using a suitable cable.



Figure 124

When a DV source is detected, the status indicator updates to read **DV Device CONNECTED**, and the transport controls become active, allowing you to rewind, stop, pause, play or fast forward the tape.

The large time-code display indicates your position on the tape, displaying values in Hours:Minutes:Seconds.Frames.

The horizontal **Jog/Shuttle wheel** is activated by dragging left or right with the mouse, in a manner similar to other knobs in TriCaster STUDIO. Select either the **Jog** or **Shuttle** switch to determine the mode of operation for the wheel.

After locating the footage you'd like to capture, press **Play** and then **Capture**. The time-code begins running to indicate clip duration. When you click Stop Capture, the time window resets, and the clip is deposited in the **Captured Media** bin. (Click **Picture** to grab a single image from the video source.)

Note: Analog sources and SDI do not provide similar machine transport controls

5.3 CAPTURED FILES

The **Captured Media** bin is where each clip is deposited as you capture. You can allow TriCaster to capture to the default folder, D:\Media\Clips, or you can create your own folder. Along the bottom of the Media bin is the **Hotlist** of frequently accessed folders.

To remove any folder from the scrollable list, select it and press the minus sign to the left. To add a folder to the Hotlist, navigate to that folder, and then press the plus sign. If you wish to rename any Hotlist entry, right click on the button and choose **Rename** tab.

NOTE: More detailed information on the Media Bin and its many great options and features is found in Section 6.1.2, The Media Bin.



Figure 125

5.3.1 IMPORTING FILES AND ARCHIVING DATA

TriCaster allows you to flexibly import compatible files via network connection, USB or FireWire external drive or USB flash (a.k.a., “thumb”) drives.

There are USB and FireWire connections on the TriCaster faceplate and rear panel. Connecting an external USB key-drive or hard drive causes that device to appear in any TriCaster **Media Bin** as a new hard drive. This means you can not only import images and clips for editing or use in the Overlay section or a DDR, but you may also copy your recorded presentations or edited videos quickly to a transportable drive for archiving or other purposes.

HINT: Highest transfer speeds can be obtained with USB 2.0 external devices

6 EDIT MEDIA

TriCaster includes one of the fastest non-linear video editors available. Editing can be performed in both **Timeline** and **Storyboard** mode, to suit your specific needs. This chapter explains the flexibility and power available for creating compelling, professional videos. TriCaster comes packed with advanced features such as multiple layers, picture-in-picture, real-time slow motion -- even color correction! In addition, the **Tool Shed** utility automates frequently used features, and also allows you to store your own custom effects and effortlessly recall them with one click.

6.1 TWO EDITORS IN ONE!

When you edit in TriCaster, remember -- you can go back and forth between **Storyboard** and **Timeline** views any time you wish. Whichever you choose, you are simply selecting a different view of the same project. Some operations (such as picture-in-picture compositions) are much easier to create in the Timeline, while for quick assembly of a project, trimming and re-ordering clips, it's very hard to beat the storyboard!

6.1.1 THE MONITOR

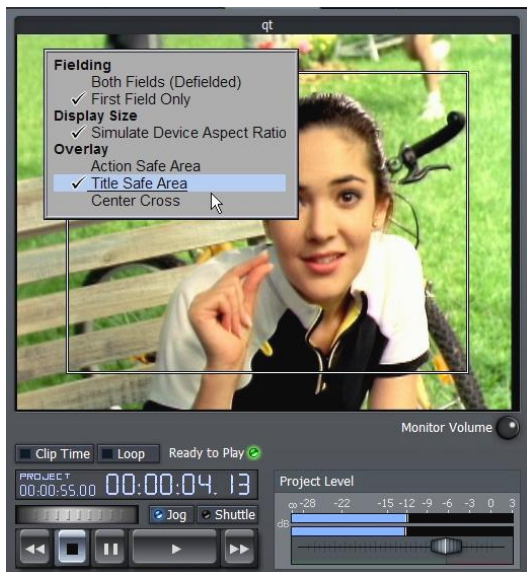

Figure 126

The **Edit Media** panel has several sections. The upper left quadrant hosts the **Monitor**, which always depicts the full composition of your edit project at the current point in time (marked by the **Edit Line** in the Timeline or Storyboard view.)

Beneath the monitor are the familiar playback controls, including a **Jog/Shuttle** wheel.

Just above these, note the **Loop** switch. This forces your entire project to play again after it has played to the end.

The nearby **Clip Time** toggle switch alternately changes the timecode display to show project time during playback and 'scrubbing', or local 'clip time'.

(Clicking the mouse directly on the timecode displays also has an effect. You can switch between countdown and count-up modes this way!)

The **Monitor Volume** knob controls the audio output level for playback through TriCaster's analog audio outputs, whereas the **Project Level** slider underneath the VU meters allows you to introduce a global audio level offset when useful for output to rendered files or using **Export to Tape**.

Right-click the monitor to reveal a menu with numerous preferences affecting the monitor display:

6.1.1.1 BACKGROUND COLOR

Select between **Grey**, **Black** or **White** to be used to fill blank areas outside of the image display in the Output Window.

6.1.1.2 FIELDING

Generally, video projects flicker on computer monitors because of interlacing. These options permit you to determine how you wish to deal with this when it arises. You may choose to show both fields with de-interlacing applied **Both Fields (Defielded)**, or **First Field Only**.

6.1.1.3 DISPLAY SIZE

Unlike computer displays, standard definition video pixels are rectangular, not square. When **Simulate Device Aspect Ratio** is disabled, every pixel in your imagery is displayed on the computer monitor 'as-is'; that is, without adjusting the display to show image proportions correctly. With this option enabled, the display is scaled to produce a properly proportioned image, just as it will appear on a television set.

*NOTE: **Simulate Device Aspect** is a preview option – it has no effect on the actual output of the project.*

6.1.1.4 OVERLAY

Typical television displays crop the video image a bit. When enabled, the **Action Safe Area** and **Title Safe Area** options place rectangular overlays on the monitor. These can help you visualize where important features of your production will appear onscreen, taking this into account. The **Center Cross** setting subdivides your image into quadrants to assist with composition.

HINT: clicking the right mouse button often reveals different menus based on context. Many powerful features and settings are easily accessible with the right mouse button.

6.1.2 THE MEDIA BIN



Figure 127

By default, the large section to the right of the Monitor is taken up by the Media Bin.

Note: Actually, three tabs at the top of the screen govern what appears in this area. We'll discuss the features of the important Controls and Tool Shed panels a bit later on.



Figure 128

The Media Bin is where you locate all your audio, video, graphics and titles. You can also use its tools for asset management, creating and organizing folders and files, and personalizing the view the Media Bin provides of these assets.

In the default view (and several of the optional ones) you will see a thumbnail image icon for video files.

At the top of the Media Bin, rectangular list boxes show the various levels down to the current folder you are viewing. Click directly on a box to jump back to that location.

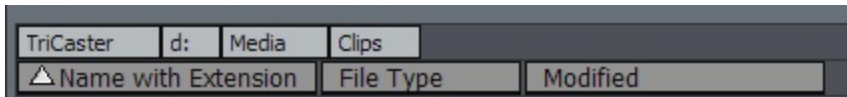

Figure 129

Roll your mouse over a thumbnail icon, and it begins to play the video scene in miniature!

As well, a small running timecode panel shows the current location in the clip, and its duration. Video projects often involve many similar clips. This animated preview is a great help in distinguishing one clip from another.

Hint: Sometimes, a longer clip may best be distinguished from a similar one by viewing a bit near the end. To reverse the direction of the preview, hold down the ALT key. You can also engage Fast Forward and Fast Reverse, by adding the Shift key to the operation (The Shift key causes playback at 10X the normal rate.)

6.1.2.1 VIEW OPTIONS

The **Media Bin** drop down menu in the upper right corner controls the appearance of items in the Bin. By default this menu is set to Large Icon. You can use this menu to radically alter the Filebin's appearance and features.

Try the different view options out, and you'll quickly see how they affect the display.

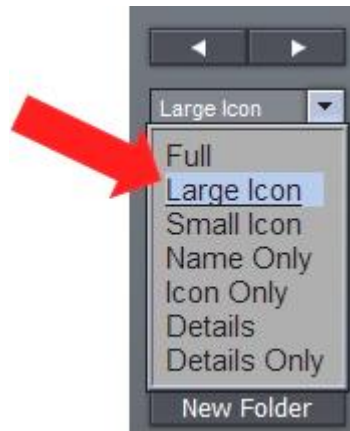

Figure 130

*Note: the right/left arrow buttons above this menu are **Forward** and **Backward** buttons for the Media Bin window.*

The only view option that requires a little longer explanation is the **Details** view (**Details Only** is similar, but minus the file icon.) Details view gives you a lot of in-depth information about your files:

TriCaster	d:	Media	Clips
△ Name with Extension	File Type	Modified	
AmericanFlag.avi	avi	4/7/2005 11:56 AM	
Bici.avi	avi	4/7/2005 11:56 AM	
China_Kids.avi	avi	4/7/2005 11:57 AM	
China_Opera.avi	avi	4/7/2005 11:57 AM	
China_Opera2.avi	avi	4/7/2005 11:57 AM	

Figure 131

TriCaster	d:	Media	Clips
△ Name with Extension	File Type	Modified	
AmericanFlag.avi	avi		
Bici.avi	avi		
China_Kids.avi	avi		
China_Opera.avi	avi		
China_Opera2.avi	avi		
China_Temple.avi	avi		
Clown.avi	avi		
DogCU.avi	avi		
Pinwheels.avi	avi		
PlaneFlying.avi	avi		
QuickTour.avi	avi		
Tone_-0db.WAV	WAV		
Train.avi	avi		
TV-ChewingGum.avi	avi		
TV-DickVanDyke.avi	avi		
TV-ManiaTV.avi	avi		
VideoClip.avi	avi		
VideoClip001.avi	avi		
+ - Transitions	Clips	Pictures	Titles

Remove Column

Name

Name w/o Extension

Name with Extension

Extension Only

Full Path

Path Only

File Type

Modified

Length

Has Video

X Resolution

Y Resolution

No Frames

Still

Frame-rate

Fielded

Even Field First

Has Alpha

Aspect Ratio

Has Audio

Sample Rate

Channels

Sample Depth

Created

Last Accessed

Size

DOS 8.3 filename

Hidden

Read Only

Animate Icon

Video Codec Decoder

Pixel Format

DV Audio

Start Time

Audio Codec Decoder

Video Codec Encoder

Audio Codec Encoder

Recording Source

Timed Recording

Timelapse recording

Figure 132

The *column labels* at the top of the Details view do more than just identify the column. Clicking a column label toggles the file sorting order based on entries in that column. Also, column labels can be dragged left or right then released to re-arrange the order. Drag the dividing line between two columns left or right to change the width of the column.

Also, the column labels have a unique context menu of their own. Right-click on a column label (or in the empty space to the right of a column) to open this menu:

In addition to **Remove Column**, you can select from a long list of file attributes that may identify or distinguish various file types. Select one of these entries to modify the current column contents or add a new column.

In addition to helping with the occasional ‘spring cleaning’ of your storage system, Details view can greatly assist you to differentiate and organize elements of your project, and quickly drop large groups of files into a Storyboard or Timeline pane.

Hint: In all view modes, if you click one file, and then hold Shift down when you click another, you can select all the files in between.

Or, click multiple files while holding down the CTRL key to select many files – when you drag them into the Storyboard or timeline, they will be added in the order you clicked!

Hint: The labels of files that are already in use in the current project are displayed in bold text.

6.1.2.2 THE HOTLIST

If you have a folder you frequently access, you can add it to the **Hotlist** at the bottom of the **Media Bin** pane. Navigate to the folder you want to add, and press the '+' sign in the lower left corner of Media bin.



Figure 133

When you right-click directly on a Hotlist button, a two-item menu pops up. You can **Remove** the selected entry, or **Rename** it. The Rename option creates a 'nickname' for the current folder, and refreshes the Hotlist to display it. (If your list is wider than the bin, there is a scroll gadget lower right.)

6.1.2.3 CUT, COPY, PASTE

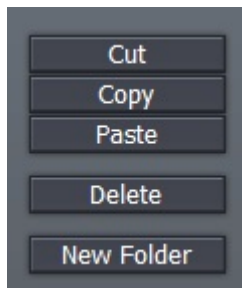

Beneath the View options menu are **Cut, Copy, Paste** and **Delete** buttons. These operate on the currently selected items in the Media Bin window.

Of course, the common keystroke shortcuts also work in the usual manner (CTR+c for Copy, CTRL+v for Paste, CTRL+x for Cut, and the DEL key to Delete a file.)

Figure 134

Note: You can also create a New Folder by selecting that entry from the menu that appears when you right-click in an empty spot in the Bin window.

6.2 THE EDITOR – OVERVIEW

The Edit pane takes up the entire lower section of the Edit Media screen. This editor is flexible, fast and friendly. It is also forgiving -- whether you choose to work in the **Storyboard** or **Timeline** views, you can undo edit operations with Ctrl-z, all the way back to the beginning of the project!

(When you **Save Project**, you are even offered the opportunity to save your **Undo Stack** to disk, so the next time you load your project you can undo from the last session!)

6.2.1 CONTROL PANEL

A column at the right hold clip and project control functions. At the top of the column is the **Timeline Ripple** switch. When Timeline Ripple is enabled, changing the In or Out point of a clip causes all subsequent clips to ripple by the same amount.

So, if you decrease the length of the clip by two seconds, all the clips after it on the Timeline also adjust to new positions two seconds earlier. Ripple doesn't affect the duration of the affected clips, just where they occur on the Timeline. (The Storyboard is always in Ripple mode.)

6.2.1.1 EDIT MENU

The **Overlay** button activates transparency around clip edges (and enables the alpha channel in files formats that support it) so it can be layered or scaled down as a picture-in-picture. The 'y' key is a shortcut to toggle Overlay on and off for a selected clip.



Figure 135

Cut, Copy and Paste are self-explanatory, and the standard keystroke shortcuts work here, too. **Remove** takes a clip out of the project, but does not delete it from the hard drive.

6.2.1.2 PROJECT MENU

You can save and re-load your TriCaster video project using the buttons in the Project section of this right-hand column, as well as starting a fresh piece using **New Project**.

6.2.1.3 FILE I/O

Import From Tape - This button requires an active IEEE1394 connection to import video footage from an external DV or HDV device.

Import from Tape pops up a window with controls similar to the one in the main **Capture Media** panel. In addition to transport controls for the external DV device, however, you will see three 'new' buttons:



Figure 136

Auto Chop will cause your captured file(s) to be automatically severed and a new file started at 'scene breaks' – wherever the camera was stopped and started. This is a great timesaver!

Use the **Chop** button to break off Capture to the current file, and immediately commence recording another. (Repeated use of Chop can quickly populate your project with ready-to-trim content!)

Note: A couple of frames may be lost between scenes when you use Chop. While generally they will not be missed, using Chop means sacrificing the possibility of re-joining the resulting clips in your project for seamless playback.

The **Reset** button actually drops the current clip being recorded, and restarts from the current point in the source material.

Note: Even though TriCaster is a standard definition video device (and edit projects are always SD, you can capture HDV files using Import from Tape.

Export to Tape - This feature uses the IEEE 1394 Preview to send the current project to a DV device (As noted elsewhere in this manual, HDV files can be captured by TriCaster. Ultimately, however, the **Edit Media** section output is standard definition – hence HDV export is *not* supported.)

Deck controls are provided in the panel that pops up to assist you in locating the desired point on the tape. You do not need to engage tape play beforehand; recording is begun immediately on clicking the Go button. During recording to tape, the interface is locked (apart from the Cancel button.)

Note: Particularly intensive sections of edit projects may stutter during playback (e.g., segments with many overlays, such titles or picture-in-picture compositions).

When necessary, you can avoid problems during Export to Tape (or any other time) by dragging the **Force Render** filter from the **Filters** folder onto the Timeline. Position this effect at the bottom of the recalcitrant project segment, and stretch it to last as long as necessary.



Figure 137

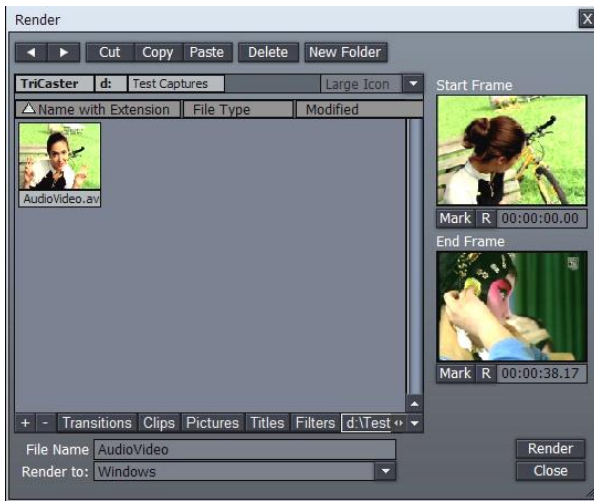

Figure 138

Render - If you wish to render out the project, consolidating it into a single file for playback in the DDR, or to archive, the Render button in this section helps you do this.

Clicking it presents a file requester, as seen here. Find or create the folder you want to store the rendered file in, and supply a File Name. The Render To menu lists many convenient formats you can select, including DVD compatible options, and even formats for popular mobile devices.

Note the useful “TriCaster Overlay” render option, which preserves transparency!

If you only want to render *part* of a larger project, drag left or right on the **Start** and **End Frame** thumbnail windows to select suitable frames, then click the **Mark** buttons beneath. (Clicking the nearby [R] buttons **Resets** the frame to the default.)

Hint: one of the two TriCaster Overlay render presets retains the alpha channel!

6.2.2 EDIT PANE VIEW OPTIONS

Just to the left of the **Overlay** button is a button (the downward triangle) which opens a menu presenting many *options* affecting the Edit pane.

The **Storyboard** option list is shorter, but can be quite useful: choose from several views, selectively displaying all project components, just the audio or video elements, or only transitions or overlays.

The list of options is longer for the **Timeline** view than Storyboard:

To reduce system overhead (or just to suit personal taste) you may separately modify the way image thumbnails appear for your various project components – Clips, Transitions, Overlays or Effects.

At the top of this menu for both **Timeline** and **Storyboard** mode is the **Time-Bar Tracking** option (the setting is shared by both edit panes.) By default, Tracking is enabled. This permits the edit pane display to scroll freely during playback to keep pace with the **Edit Line** (regardless of the Zoom level.)

6.3 THE STORYBOARD

Storyboard mode is the simplest starting point for video editing, offering a straightforward interface that sequences one clip after another in an easy to grasp manner. The Storyboard allows very quick sequencing of clips simply by dragging to a new project location.



Figure 139

6.3.1 ADDING CLIPS TO THE STORYBOARD

In the **Media Bin**, navigate to the folder where you have saved your video. If you know the order of the clips in your program, you can Ctrl-click each in order in the bin to select them. Then, when you drag them all at once onto the Storyboard, they will line up retaining your selection order! (Of course you can also add clips one at a time.) You can also multi-select clips in their natural order in the Media Bin by selecting the first clip, then holding down Shift when you click the last one.

To *insert* a clip *between* two others on the Storyboard, just drag its thumbnail from the Media Bin over the Storyboard and drop it between them. Rearranging clips works the same way, by dragging thumbnails to new positions on the Storyboard.

6.3.2 TRIMMING CLIPS

The blue and green bars across the top of each icon in Storyboard represent the audio and video portions for each clip -- video is shown as blue, and audio is green.

Note: Still images have no bar at the top; Transition icons are a smaller, and also have a blue bar.



Figure 140

Adjust the **In Point** by holding down the Alt key and placing the cursor over the left half of the icon, so it reads “IN”. Drag horizontally to set a new In Point. Adjust the **Out Point** by placing the cursor over the right side of the clip and dragging horizontally while holding the Alt key.

Alternatively, you can press the left/right arrow keys to move the **Edit Line** frame by frame to the exact spot you intend, using the Project monitor as a reference. Then press either the i key or the o key on your keyboard (i for In Point and o for Out Point.) Depending which key you press, the In or Out Point for the clip immediately snaps to the Edit Line.

Hint: If you're nimble, you can even adjust In and Out Points on the fly! Just double-click a thumbnail icon on the Storyboard to start playing at that clip, then hit i and o as the clip plays (this works with just one clip at a time, mind you.)

6.3.2.1 TRIM AUDIO ONLY

To alter the audio edit points only (without adjusting the corresponding video clip) hold down Alt + Ctrl as you are dragging. The green bar will move, but the blue one will not.

6.3.2.2 SLIP AND SLIDE

To move an In or Out while maintaining the length of a clip, you can perform a **Slip and Slide** operation. Hold down Alt + Shift and the cursor says S/S. As you drag the mouse, the bars move left or right accordingly, yet remain the same length. (The keystroke shortcut for 'audio-only Slip and Slide' is Alt + Shift + Ctrl.)

6.3.2.3 DEFAULT IN AND OUT POINTS

When you bring a clip into the editor, the software automatically sets the In Point one full second after the beginning of the clip; likewise, the Out Point is set one second before the end. This gives room for the addition of seamless transitions. Of course, you can always manually adjust the In and Out points yourself as the whole clip on file is available.

Hint: If you really want the first frame to be the beginning of the clip and the last frame the end, you can highlight the clip and hit the g key. (To maximize multiple clips in this manner, use the Tool Shed routine Video>Maximize Lengths.)

6.3.3 STORYBOARD RIPPLE

Rippling is intrinsic to Storyboard editing, and cannot be disabled. In a Timeline view, shortening a clip might leave a gap between clips, a black section of the project with no video playing – this will never occur in the Storyboard due to the ‘full-time’ Ripple mode.

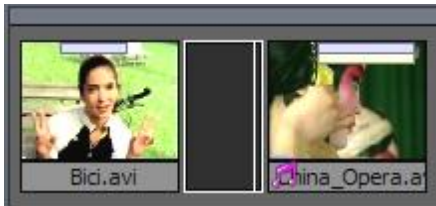

Figure 141

On the other hand, depending on your chosen Ripple mode, Timeline operations can often result in such gaps. A gap may sometimes be a deliberate edit decision, but at other times may occur inadvertently. Finding and eliminating these gaps can be very time-consuming in Timeline view, especially if you are zoomed way out on a long project.

The Storyboard comes to the rescue once again in these cases. Gaps are represented on the Storyboard by an easily discernable narrower-than-usual black thumbnail. Just click this icon, and press DEL on the keyboard, and the Storyboard Ripple feature will close the gap easily.

6.3.4 INSERTING A TRANSITION



Figure 142

One simple way to insert a cross fade is to highlight the clip you wish to fade *from*, then press Alt-f. If no clips are selected when you press Alt+f, cross fades will be applied between all clips!

There are hundreds of great transitions available in TriCaster’s **Transitions** folder, and the Storyboard interface makes it a breeze to use these.

Simply drag the desired transition from the Media Bin between two clips in the Storyboard pane!

Hint: If you wish to replace a fade or transition with another, you can Alt-drag a new transition on top of the original, inheriting the settings already established.

The thumbnail icon for a Transition will appear slightly smaller than that of a clip.

6.3.5 STORYBOARD PLAY OPTIONS

To play a clip, double-click it to start playing at the **In Point** and to stop at **the Out Point**. Hitting the Spacebar will pause playing the clip. Hit the Spacebar again to resume playing. Whereas the double-click play ended at the last frame of the (trimmed) clip, however, pressing Spacebar again puts the Storyboard into continuous playback. The entire project will play until it comes to its end or you manually Pause or Stop

Note: When a clip is playing, the edit line crawls along the Storyboard icon giving you a visual reference of your current position in the clip. If you hit the right arrow key on the keyboard, the clip pauses. Click the arrow again and it advances one frame. Hold the arrow down and it plays the clip. Hold Shift + arrow and the clip will advance five frames at a time (the left arrow key plays in reverse.)

For a quick review of a clip, Shift + Spacebar begins playback *three seconds* prior to the actual current position in the project (this is especially useful for reviewing the cut point at the boundary between two clips.)

You can play the whole project in a number of ways. On the keyboard, hit Home to jump to the beginning of the project, and then press the Spacebar.

6.3.5.1 J, K, L HOTKEY CONTROL

The keyboard shortcut, k, will also play the project (to be precise, the k shortcut toggles Play/Pause.) Pressing the neighboring speeds up the current rate of play – pressing it again speeds it up even more. Conversely, pressing the j key slows down the current rate of play; depending on the current rate of play, it will even reverse playback. Pressed repeatedly, the j key produces fast reverse playback. (See Appendix B – Keyboard Shortcuts for the full list of hotkeys available.)

6.4 THE TIMELINE

TriCaster's **Timeline** is where most of the advanced capabilities await you. The Timeline is the best place to see relationships between audio, video and titles. It is also the only place you can easily manage overlapping layers.

TriCaster has a free-form timeline, meaning that you can place audio, video, and titles anywhere you need. TriCaster's Timeline can be described as 'top-down,' meaning that in multi-layered edits the base layer is at the top of the Timeline window, with foreground layers towards the bottom.

Hint: (For example, to set up a simple picture-in-picture, you would place the clip you want in as the "pip" in the lower layer, and then use the Controls panel to scale it down and position it to taste, and finally turn on Overlay.)



Figure 143

Take a look around the Timeline. If you are an editor, you might be spending a lot of time here, so become familiar with the neighborhood.

The Timeline interface is composed of three elements: the **Edit Line** (marking your current temporal position in the project), the **Time Bar**, (the horizontal strip showing timecode at the top of the pane) and the **Tracks** that hold your clips. The area to the left of the main time area is hashed, indicating "negative time."

6.4.1 THE EDIT LINE

The **Edit Line** is the essential guide to indicate where you are in the project, and if you place the cursor over it you can drag it left or right (called scrubbing). The Time Bar across the top of the Timeline indicates at what timecode position the Edit Line is. Clicking anywhere in the Time Bar will cause the edit line to jump to that location.

*Note: sometimes a lower layer in the timeline hides a clip you wish to view temporarily while editing. A special feature called **Local Scrub** permits you to view any layer without obstruction. To use it, hover your mouse along the bottom edge of the clip in the timeline, and the cursor will show a double-headed arrow and the word “Local”. Drag left or right to scan through just that clip.*

If want to jump to a specific time code location, you can press Ctrl-g, and enter the desired timecode into the pop-up window in the format of HH:MM:SS.ff (hours, minutes, seconds, frames). It is not necessary to enter any leading zeros. So, If you wish to jump to the 3 minute portion of my project, enter in 3:00:00.

6.4.2 ADDING CLIPS TO THE TIMELINE

The procedure for adding clips to the Timeline is exactly the same as in the Storyboard. In the **Media Bin**, navigate to the folder where you have saved your video. If you know the order of the clips in your program, you can Ctrl-click each in order in the bin to select them.

Then, when you drag them all at once onto the edit window, they will line up retaining your selection order! (Of course you can also add clips one at a time.) You can also multi-select clips in their natural order in the **Media Bin** by selecting the first clip, then holding down Shift when you click the last one.

Newly added clips are inserted the project beginning at the point where you release the mouse button after dragging over the timeline pane.

Note: TriCaster’s ‘trackless’ timeline actually permits you to overlap more than one clip on a track, so it’s possible to drop a clip into the project in such a way as to completely cover another one on the same track. Usually you will want to avoid this by dragging new inserts into an empty spot on the timeline.

6.4.3 INHERIT

Occasionally you will make changes to a clip, (for example, shorten it or resize it), then later decide that you need to replace it in the Timeline or Storyboard with another clip. With the **Inherit** feature, when you drop the replacement clip on top of the original, the second clip acquires the properties of the original.

Inherit also makes it easy to drop in placeholder clips for scenes that you have not shot yet. You set the timing, position, or other options on the placeholder clip and continue editing. When the replacement shot is ready, you just hold down the Alt key and drag and drop it onto the placeholder to inherit the placeholder's settings. (This is also a great way to modify just those parts of a frequently used composition of graphic elements and video clips, maintaining a common theme throughout your productions.)

To **Inherit Settings**, first click the replacement clip in the **Media Bin** to select it. Hold the Alt key as you drag and drop it onto the original clip. The original clip disappears as the new clip replaces it.

6.4.4 ZOOMING AND SCROLLING

The **Time Bar** depicts major and minor time increments with timecode and tick marks. You can scroll through the Time Bar with the scroll bar at the bottom of the pane. Just click and drag it left or right. Roll your mouse on either end of the scroll bar to zoom in or out. When the cursor says zoom, click and drag your mouse away from the bar to zoom out horizontally, and toward the bar to zoom in horizontally. (If you hold the Shift key when you zoom, it constrains the other end of the zoom.)

Another convenient way to zoom in on the Time Bar and your clips is to use the scroll wheel, if your mouse is so equipped. Using the wheel to zoom your active timeline view will always center the zoom on the location of the **Edit Line**.

NOTE: As elsewhere in TriCaster, if you press Ctrl while dragging the operation will be 10 times more precise. This is true for all sliders and knobs, including zooming using the scrollbars.

As is so often the case in TriCaster, there are even more ways to zoom! If you move the mouse up to the Time Bar, with a single click-and-drag operation you can pan horizontally and zoom simultaneously! Right-click on Time Bar, and drag left or right, and the timeline view pans. If you drag up or down, you zoom in or out!

HINT: To quickly see the entire project in the Timeline pane, double-click in an empty area of the Timeline. (This works in either the Storyboard or the Timeline panes, when no clips are highlighted.) If a clip or clips are selected in the Timeline view, you can double-click in the Time Bar, or hold down the Ctrl key while double-clicking in the background of the workspace, to zoom in on your clip selection.

NOTE: Click the magnifying glass at the bottom of the vertical scroll bar on the right To modify the height of the tracks. Pull up to enlarge the tracks and down to shrink them.

6.4.5 TRIMMING CLIPS

There are several ways to trim clips in Timeline: you can place the cursor over the edge of a clip so it changes to display 'IN' or 'OUT' and then drag that edge to the frame desired.



Figure 144

It is possible to drag the clip edge beyond the first or last frame, and you will see hash-marks and a 'bang' (an exclamation point on a red triangle) to remind you that you have exceeded the actual first or last frame.

This will hold that frame for as long as you wish. You can also set the edit line at the frame you want, and press the i key to make that spot the inpoint or o for it to become the outpoint, and the clip will snap to its new position. Shift + i or o not only sets the in or out point, but also jump back 5 seconds and play the edit.

6.4.6 TIMELINE SNAPPING

To move a clip, simply click it and hold, then drag it. Clips in the timeline have a 'magnetic attraction' to other items in the Timeline, and tend to 'snap' to them. For example, when the bottom or top of a clip approaches a track line, the clip will jump to that spot. The clip also snaps to the vertical lines in the panel. Most importantly, a clip will snap to the Edit Line, and the In or Out point of other clips.

This tendency to snap does not prevent you from moving the clip wherever you want on the Timeline (however, clips will insist on sitting on a track line.) You can move multiple clips in the Timeline by

selecting them, and then dragging them all at once. When you drag multiple items, only the first item selected snaps. All other items maintain their relative positions to the first item.

HINT: Occasionally, you will want to move a clip up or down in the Timeline without altering its position horizontally on the Timeline. To constrain your movement to vertical dragging only, hold the v key down. It's important to click on the v before you click the mouse and drag. To conclude the operation stop dragging wherever you wish, then release first the mouse button, then the v key.

6.4.7 MARKERS

Someone famous once said, “Timeline markers are the greatest thing since peanut butter.” (OK, no one really said that ... but that doesn't mean it's not true.)

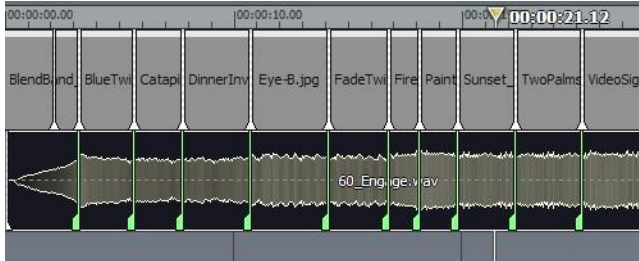

Figure 145

Markers are a great convenience. They serve as simple visual cues, like bookmarks, but offer a great deal more too! TriCaster provides two different types of timeline markers, the **Clip Marker** and the **Project Marker**.

The creation, management, and basic features of both types are identical. The primary difference between the two is their domain. While both exist within the Timeline pane, Project markers fulfill their raison d'être by clinging tightly to the global Project time. Clip Markers accompany the clip, wherever it goes.

6.4.7.1 ADDING MARKERS

You can create a **Project Marker** in several ways. With no clip selected, right-click in the background area of the **Timeline** pane to open its context menu. If you select **Add Project Marker**, voila – a new marker is

created at the current position of the **Edit Line**. It appears as a distinct thin green vertical line intersecting the Timeline display.

Adjust the current position of the **Edit Line**, but this time press the m key to create another **Project Marker**. Now you have two Project Markers.

Hint: You can even use this keystroke shortcut while the project is playing back. This permits you to easily mark visually (or audibly) significant events for later reference, or use them as placeholders for edits you have in mind for later.

6.4.7.2 NAVIGATING BETWEEN MARKERS

Jump from marker to marker in the timeline using the , (comma) and . (period) keys (or, if you prefer to think of it that way, the <, and > keys, without Shift mind you.)

6.4.7.3 MANAGING MARKERS

Remove markers as follows -- when the **Edit Line** is located at a **Project Marker**, right-click in the Timeline's background and choose **Remove Project Marker** from the menu. If more than one marker is present in the Project, the menu will also offer to **Remove All Markers**.

You can also left-click the mouse pointer directly on a marker and drag to the left or right to reposition it more carefully along the Timeline.

6.4.7.4 EDITING MARKERS

It gets even better. You can easily edit the appearance of your marker(s), adding useful information at the same time. Double-click the marker directly and up pops a small inset with three wonderful features.

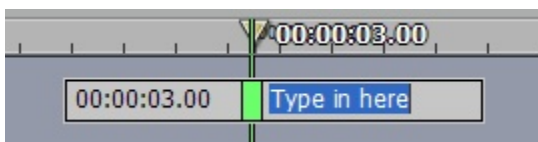

Figure 146

The **Marker Tag** field, shown in blue in the image, is active immediately after double clicking. Use this field to provide a name (brief editing notes) for the current time position.

While in **Marker Edit** mode, you also will see another direct entry field to the left of the marker. Modify the existing *timecode* value and press Enter on the keyboard -- the Marker will jump to the new position. You can even use this facility before beginning to build your project, adding a bunch of markers immediately and then entering timecode values for significant edit points decided in advance.

Centered right above the Marker is a color swatch. Click it to popup the standard Color Picker, and click a new color for your Marker. (You can use colored Markers to signify certain types of events, or simply because you've an over-developed color sense.)

6.4.7.5 CLIP MARKERS

Let's discuss the other type of Marker – the **Clip Marker**. Clip Markers are identical to Project Markers in every sense, except one.

Whereas **Project Markers** know their place in the grand scheme of things, **Clip Markers** cling limpet-like to their parent objects, such as video and audio clips. Move the clip and the Clip Marker goes right along for the ride. The timecode shown for a Clip Marker is local to the clip.

To create a Clip Marker, you need to do only one thing differently – select a clip (or clips) first, before pressing the m key (or using the menu.) In all other respects – naming, coloring, and so on, Clip Markers work just like their cousins.

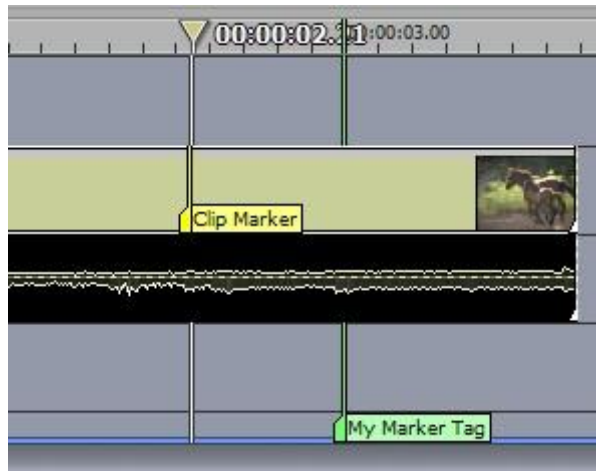

Figure 147

6.4.8 DRAG COPYING

Cut, **Copy** and **Paste** functions are available in the **Edit Menu** at right, along with their common keystroke equivalents (CTRL+X, CTRL+C, and CTRL+v). TriCaster offers another great copying convenience: if you hold down the Ctrl key before you start dragging a clip or selection of timeline items, you make a copy of the object(s) at the location where you release the mouse button. The source items remain in place.

This is a great way to quickly copy a clip ... unless, of course, you just wanted to move it -- if you do this by mistake you'll leave unwanted copies in the wake of your mouse.

Hint: Remember the earlier discussion of the Inherit feature – this is a dynamite way to quickly flesh out project ‘templates’ for regular use. You can duplicate a section of the timeline using CTRL+drag, then update one or more elements using ALT+drag to ‘inherit’ replacement items into the clips.

6.4.9 TIMELINE TRANSITIONS

One simple way to insert a cross fade is to highlight the clip you wish to fade *from*, then press Alt-f. If no clips are selected when you press Alt+f, cross fades will be applied between all clips!

You can also simply a clip so that its leading edge overlaps the out point of a neighboring clip on the same track to automatically insert a Cross Fade between the two clips (any audio associated for the clips will automatically cross fade, as well.)

Often, though, you will want to set up the transition timing yourself. First, to select one of the many other transitions available, click the Transitions **Hotlist** button at the bottom of the Media Bin to jump to that folder. Browse around until you find the one you want.

Hint: (Remember that if you hover them mouse over a transition icon, a preview will play to aid in selection.) Remember too, if you wish to replace a fade or transition with another, you can Alt-drag a new transition on top of the original, inheriting the settings already established.

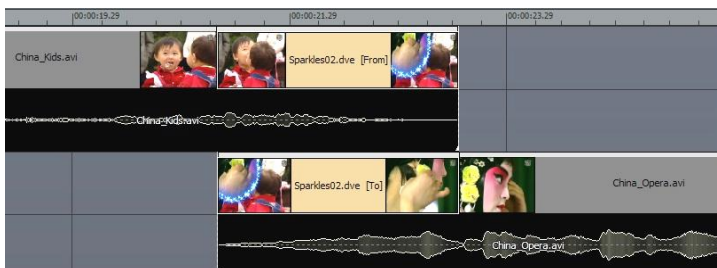

Figure 148

Continuing, manually position the timeline elements as follows: begin by overlapping the two clips vertically, on different Tracks.

Drag the Transition onto the end of one of the clips, and the result should be as shown here.

6.4.9.1 ADJUSTING TRANSITIONS

When you roll your mouse over the edge of a **Transition**, the cursor changes to a slashed frame icon, which indicates Transition edit mode is active. Click and drag the edge of the Transition to lengthen or shorten it. If the Transition is aligned with a clip, the clip's edge will move to match the Transition as you drag.

6.4.9.2 ADDING TRANSITIONS WITH THE TOOL SHED

Another way to add Transitions can be found in the **Tool Shed**. Click on the Tool Shed tab, near the **Media Bin** tab in the upper right corner of the screen. (The Tool Shed will be described in detail later, but this tool is too useful to make you wait!)

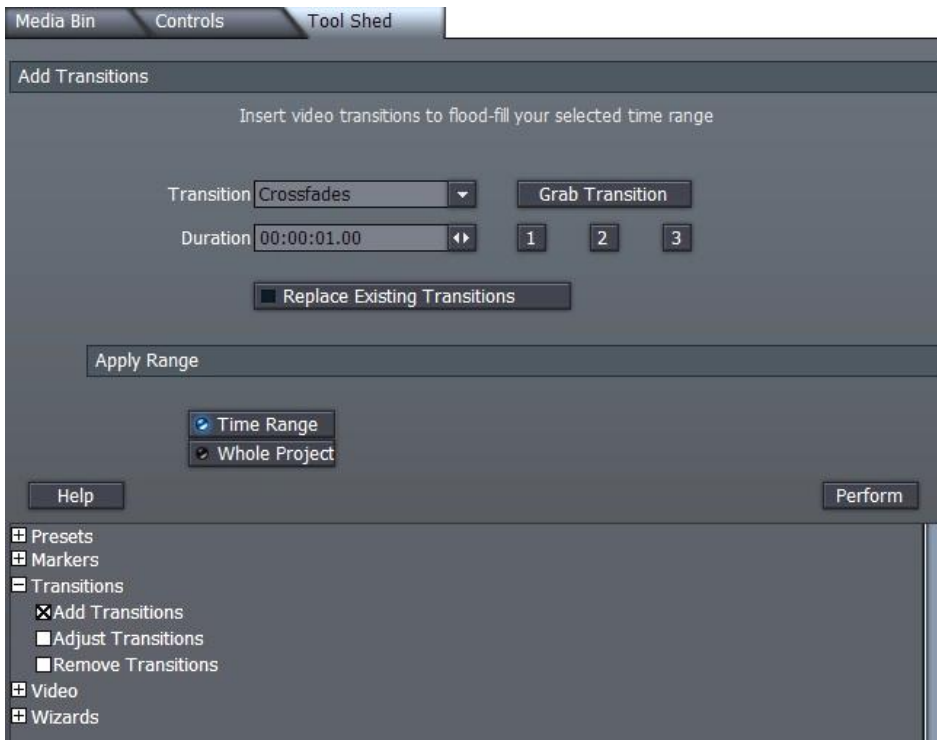

Figure 149

Click on **Transitions** entry in the category list at lower left the left, and then select **Add Transitions**. In the Transitions selection menu above, you may not find the specific Transition that you want already listed; but you can choose any one TriCaster provides. If the transition isn't in the project already, drag it out of its directory and onto the Timeline. Be sure it's selected, and then click **Grab Transition**. The Transition menu will show "User" as the current selection, and the transition name and number will then be displayed above.

Now, you can set the duration for the transition. The 1, 2, and 3 buttons are just fast ways to enter exactly 1, 2, or 3 seconds. Next choose whether the Transition will be added between every clip in the project or only applied to a specific range. Of course, if you pick Time Range, you need to go to the Timeline and shift-click a range of clips to mark that range. Then, click on **Perform** and the Transition will be added.

HINT: Tool Shed also provides powerful tools to modify, add or remove transitions.

6.4.10 FILTERS AND FADES

The **Filters** folder is listed among the Hotlist buttons at the bottom of the **Media Bin** panel, and contains some useful items for creative work.



Figure 150

Both audio and video filters are found here. To use one, you drag it from the folder onto the timeline. Generally, filters affect all tracks above their insertion point. Selecting the filter on the timeline permits you to access any controls and settings it may offer in the Controls window, discussed in depth shortly.



Figure 151

Individual clips (and audio samples) can also be forced to fade in and out in realtime directly on the timeline.

If you look closely at each clip you will observe a small triangle on the bottom corner at both ends.

When you hover the mouse over them, the cursor updates to show a double-headed arrow and the letters “Fd”, for Fade.

Dragging these triangles toward the center of the clip creates a progressive fade in or out.

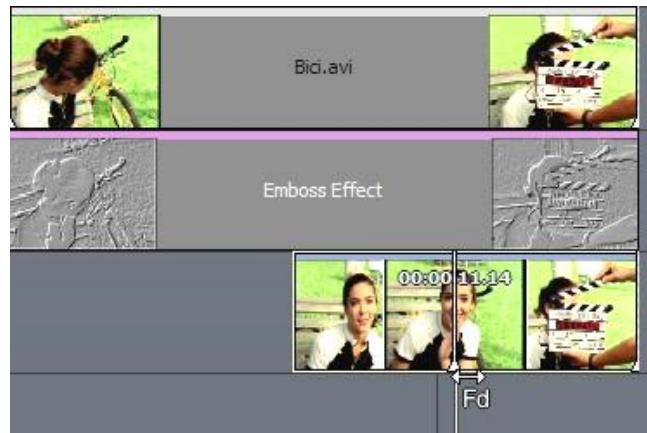

Figure 152

Note: by default, all video clips are fully opaque, so initially a Fade appears to occur over a black background. Turn on the Overlay switch in the Edit Menu to see project content in upper layers showing through the faded segment.

6.4.11 TITLES

Classy and professional CG elements, including scrolling credits, static titles, lower thirds and other graphic overlays make your presentation shine. TriCaster’s **Edit Media** panel provides powerful Titling, of “Character Generation” ability, going well beyond the capabilities of many standalone edit systems.

You can begin with a blank CG page, or quickly modify any one the supplied professionally designed Title Templates to suit your specific need. Let’s set templates aside for a few moments, and consider the three ‘blank slate’ alternatives TriCaster provides.

6.4.11.1 CREATING A CG PAGE

Titles are added to your project by first dragging a title filter icon into it.

These are located in the Titles folder, accessed by clicking the appropriate **Hotlist** button below the **Media Bin** panel.

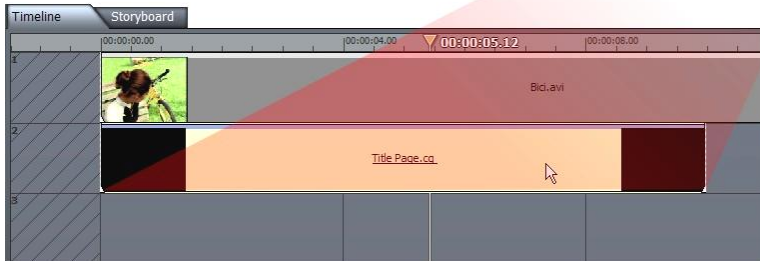

Figure 153

The first thing to do is drag one of the three CG Page icons from this folder into the timeline. Choose one of three page style icons: **Title Page**, **Scroll page** and **Crawl Page**.

6.4.11.2 TITLE PAGE

This option initially represents a straightforward static title page – the page itself and its contents are stationary. That said, the page and anything you add to it can in fact be individually animated, using options provided in the **Controls** tab. This type of CG slate is commonly used for applications where images or text all fit within one screen, such as lower thirds and introductory title pages.

6.4.11.3 CG SCROLL PAGE

Scroll pages are typically used when large amounts of text, such as lists of names or credits, will not fit on a single screen. The successive lines of scroll pages are created one above another on the page, which can be longer than a single screen. The ‘over-size’ page scrolls from bottom to top when played back.

Type text for a line and hit return to advance to another blank line. As you approach the bottom of a scroll page, the page edges upward, keeping your current line in view so you can continue entering text. If you wish to highlight all text, you can left-drag across the page or use Ctrl-a (this allows you to globally justify all of the text you entered to left, right or center.)

6.4.11.4 CG CRAWL PAGE

Crawls move horizontally across the screen. They are used when you wish to display a lot of text without obscuring the screen (such as to display a news feed or weather alert).

NOTE: CG Scrolls and Crawls can require a lot of processing. Often the first time you play through a CG page, it will stutter, and the Ready to Play LED at right under the monitor will remain red. Play through the page once, and it should be ready for smooth playback after the ready light turns blue again.

6.4.11.5 ADDING TEXT AND GRAPHICS

Let’s detail the creation of a basic title page. Drag the **Title Page filter** into the timeline beneath another video clip, and highlight it. To continue, we need to visit an area of the Edit Media panel that we’ve not looked at before. Click the Controls tab in the top right quadrant. The Controls panel will replace the Media bin to fill that pane.

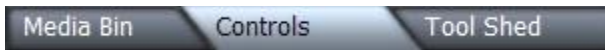

Figure 154

The **Controls** panel contents vary, depending what sort of timeline item is currently selected. When a title page is selected, the pane is sub-divided into three sections – an interactive **title composition window**, a **settings panel** below that, and a **tools panel** at right.

At first, the **composition window** will be blank, showing only the **Safe Area** display. This is because you haven't added anything to the page yet. There is also a row of tabs across the very bottom of the Controls panel. It has separate tabs labeled **Title**, **Draw**, **Color**, **Styles**, **Options** and **Positioning**.

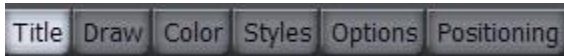

Figure 155

Selecting one of these tabs may modify the view in the **title composition window**, and also presents different controls in the **tools panel** at right.

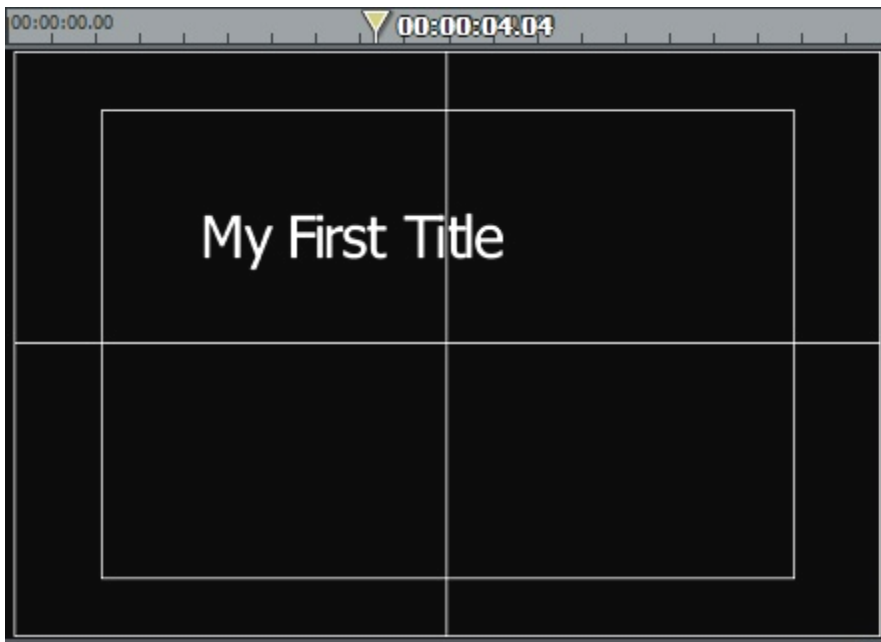

Figure 156

To enter some text, click the **Title** tab at the bottom of Controls, and click on the **title composition window** to display a blinking text entry cursor.

(You can freely reposition text later, but it's wise to keep entries within the smaller Safe Area box, the 'title safe' area.)



Figure 157

After clicking in the window, type some text.

Take a look at the buttons in the **tools panel** (to the right of the **composition window**.) Many of the options shown with the Title tab selected are self-explanatory. Let's start with the section labeled **Compose**.

Click a few of the justification buttons to the right to see how they affect your line of text. Justification is relative to the title safe boundaries.

The three buttons shown at right modify the placement of newly entered characters as you type.

The default is left to right in 'normal' fashion.



Figure 158

Clicking the button with the down-arrow on it causes new characters to appear on screen vertically, from top to bottom. The third option is right-to-left, very useful when you are entering long scroll text lines.

You can select a different font using the drop down menu supplied, and checkmark **Bold** or **Italic** to taste. Beneath this are switches to enable or disable **Shadow** or **Edge** (colored outline.)

Left-click the color swatches to the right of **Shadow** or **Edge** to pop up the system **Color Picker**, or right click the swatch, and drag it anywhere on the interface (the Edge swatch is actually a double one, with left and right sections permitting graduated color applications.)

As you drag, note how the swatch updates to reflect the color under the cursor at any given time. Release the mouse button to choose that color. (This is a great way to ensure your colors perfectly match those in your video clips.)

Note: A similar color swatch next to the Italic switch allows you to modify the default color used for the main face of your text.

The **Edit** buttons between the color swatch and the **Shadow** and **Edge** buttons permit interactive adjustment of these two attributes. Clicking Edit for either option first enables the option so you can observe the impact of changes you make.

Then, if you opted to **Edit** a shadow, when you move the cursor over the object it becomes a 4-pointed star, indicating you can now drag the shadow without affecting the text itself. Try this, and watch the result on the main Edit monitor. When, if you click the **Edit** button for **Edge**, the pointer becomes a circular outline with an arrow reminding you to drag – dragging left or right will increase or decrease the width of the outline around the CG object.



Figure 159

Click the **Arrow** button in the Compose section of the tool panel, and your text is bounded with a box. You can **scale** the text by dragging a corner or a side, move it by dragging inside the box, and even **rotate** it by holding down shift and dragging a corner!

6.4.11.6 GROUPING OBJECTS



Figure 160

The Object section at the bottom of the tool pane is not difficult to use. Beyond the obvious, you can group CG objects together to act as one by multi-selecting them, and clicking the Group button (we leave it to the reader to guess what Ungroup does) 😊

Note: To multi-select items on the screen, you have two options: you can drag a marquee around them with the mouse, or CTRL-click them individually.

The **Depth** buttons in the same section move the current object forward (towards the foreground) or backward one level per click, allowing you to arrange objects on the screen in front to back order as you please.

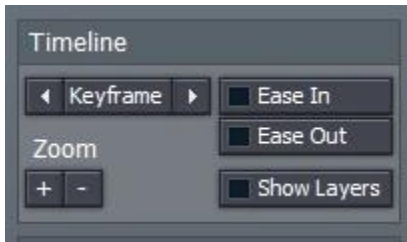

Figure 161

6.4.11.7 ANIMATING TITLES

We deliberately skipped over the uppermost section, labeled **Timeline**. Let's consider it now. Notice the Keyframe button? Yes, you can animate any line of text or CG object!

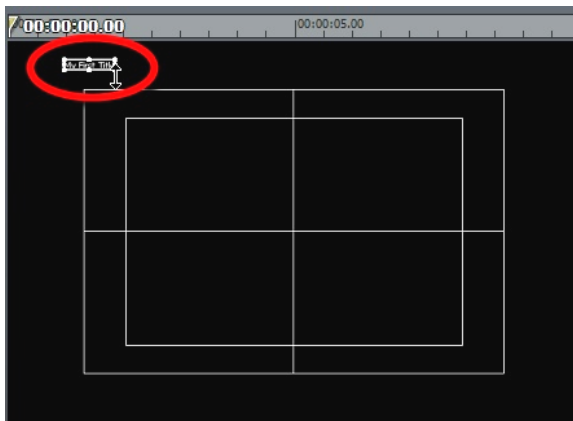

Figure 162

Move the **edit line** in it all the way to the left (the first frame of the selected filter), and click the **Keyframe** button to mark this spot.

Let's test this out. First though, let's note a couple of useful features: the **Show Layers** button will show the project content behind the title page you are working with. And **Zoom In** and **Out** make it easier to work with small objects, or outside the standard video frame.

These can both make your current job easier at times. **Zoom out** a bit, and then drag a line of text to the upper left corner of the **composition window**, placing it just outside the active video frame.

The **composition window** has its own time bar.

Now, move the **edit line** to the right – for this example, use the 6 second mark. Drag the text to a new position on the screen, as shown in Figure 163..

Hover the cursor over one of the title objects corners, and drag to make it much larger. By moving to a different point in time and adjusting the size and position of the object, you automatically created a second keyframe for those values.

Once the **Ready to Play** light illuminates, you have an animated title!

Note that a small pink vertical mark has been 'left behind' at the left end of the **time bar**.

This mark indicates that a keyframe exists. If you click the left arrow beside the **Keyframe** button, you will jump back to that previous keyframe position – click the right arrow and you return to the next keyframe, at 6 seconds.

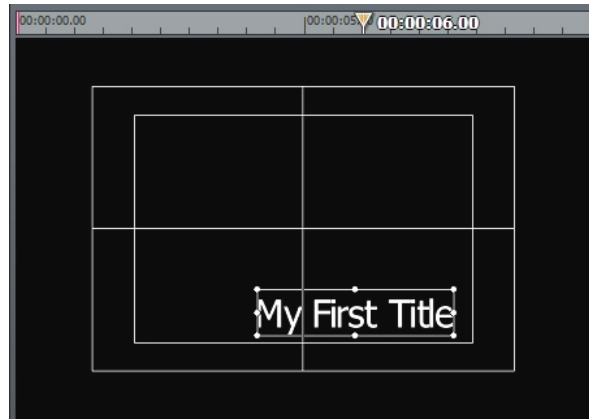

Figure 163

Hint: If you create a keyframe inadvertently, simply jump to it, and then click the Keyframe button again to remove it.

Our title animation could stand a little refinement. First, we can see that it is slamming into its at-rest position. It would be nicer if it would slow down and 'park' gently. Jump to that Keyframe, and click the **Ease In** button. Play your animation again – that's much better, isn't it?

Let's add a fade-in to the motion effect. We could simply use the fade triangle control on the Title Page clip in the timeline, but let's take this opportunity to briefly explore the **settings panel** beneath the **composition window**.

6.4.11.8 THE SETTINGS PANEL

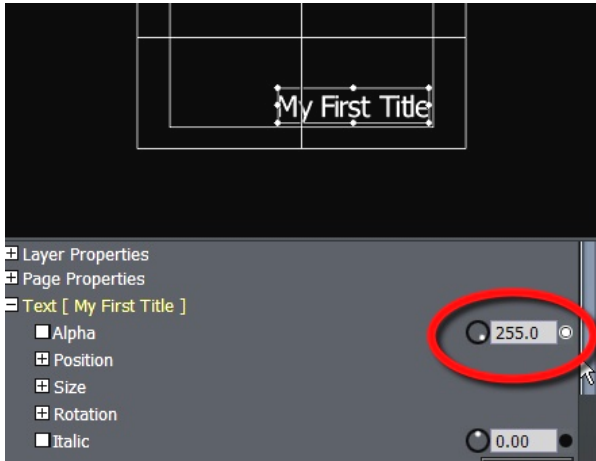

Figure 164

Click the **[+]** button next to the Text label in the column of properties listed in the **settings panel**, to expand the list of text attributes we can control here.

The first item in the expanded list is **Alpha**, which refers to the opacity of the current object. Fully opaque is represented by the value 255, which is the default.

Click the small button to the right of the numeric field and it will turn white, indicating you have set a **keyframe** for the value 255 at the 6 second mark of your title animation.

Now scrub the time bar above the **composition window** back to the first frame, and enter the value 0 for **Alpha**. The title will begin its travel fully transparent, and gradually attain full opacity as it parks into its resting position!

Take a moment while you're here to note the nearly endless list of items that can be animated and precisely controlled in the **settings panel**! You could expand the **Position** group just below alpha and enter very precise values here. Or keyframe the **Reveal** value, which can be used to make it seem as though your text is being typed onto the screen one letter at a time.

To fully cover all of the creative options provided here would take another manual, so let's move on to consider the features presented in the Draw tab.

6.4.11.9 THE DRAW TAB

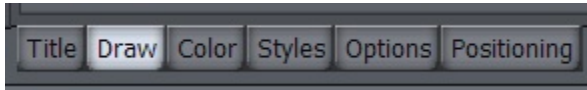

Figure 165

Our white text can be less visible than we might like when viewed against a busy video 'background'. Let's create a stationary rectangle that will appear behind it, setting it off from the video behind.

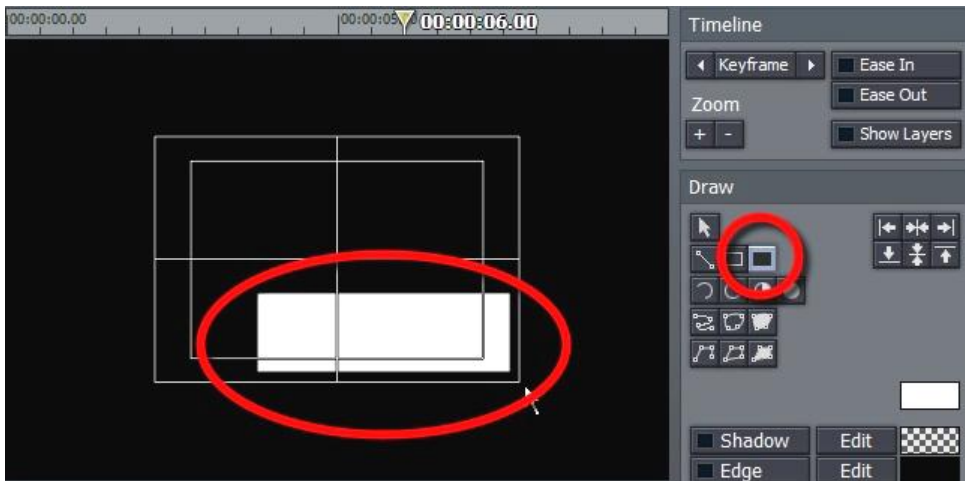

Figure 166

Click the Draw tab at the bottom of the Control pane, and select the **Filled Rectangle** drawing tool. Drag out a rectangle a bit bigger than your title (at its largest size.)

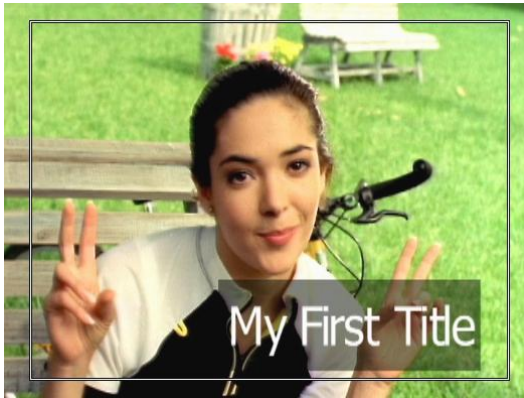

Figure 167

The new CG object (your rectangle) is on top of the text, hiding it – let's fix that, but first let's also change its color. Click the **Arrow** button, and then click the rectangle to select it for editing.

Now click the main **color swatch** to pick a different color for the rectangle's face (we're going to change this later, so for the moment just use any easily visible color.

Then, click the **Depth** button to position the rectangle *behind* your existing text object.



(You may wish to resize and reposition the rectangle a bit at this point, to conform to the size of the title.)

Right, that's more sensible. Now, use the main **color swatch** again to change the rectangle color to black or dark brown. Look in the **settings panel** for the **Filled Rectangle** entry in the list, and expand it by clicking the **[+]** button.

Set the **Alpha** value to 128. Your result should look something like this.

Figure 168

Later, you'll want to experiment a bit with the drawing tools – they are amazingly capable. Combined with adjustments in the settings pane, you can draw - and animate - almost any shape you wish!

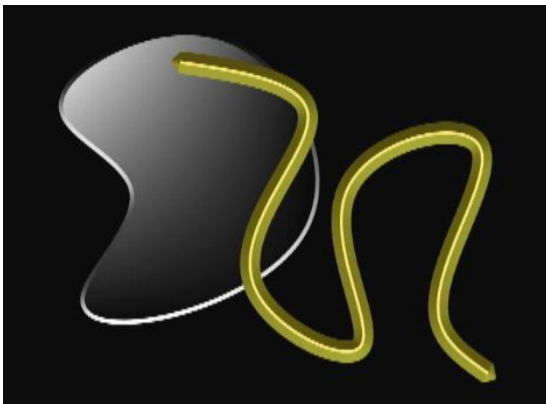

To end a drawing operation with one of the spline drawing tools, double-click the mouse. Spline objects such as lines and filled shapes can be modified after their creation, as well:

Select the object and resize it in the usual way, or hold down Shift while dragging just outside a corner to **Rotate** it. If you press shift while right over a corner, you can **Shear** (italicize) the object by dragging.

Figure 169

You can even add and reposition the vector control points defining the object. To do this, hold down the Alt key. As you near a control point, the cursor will read **Delete** – click a point to remove it. Conversely, when you are above a vector line but between control points, clicking the mouse button will **Add** a new point, which you can then freely position (when you are right above a control point with ALT pressed, you can reposition it.)

6.4.11.10 STYLES

Let's continue our tour of the tabbed panels.

The default white text is a bit bland, so select your text object in the **composition window**, then click on the Title Styles tab lower right. Here you are presented with a wide range of text treatments.



Figure 170

With your text still bounded in its box, you can click on any style, and the text assumes those settings. Any style can be modified and added to the styles bin.

6.4.11.11 THE OPTIONS TAB

Click the **Options** tab next, and you will see an array of convenient tools and display options to assist you in creating your CG masterpieces.

Use the **Grid** to carefully position items in a row or column (**Snap** can help with this.)

Guides are lines you add wherever you like temporarily to assist with alignment – they never appear in the result. Click **Add Vertical** or **Horizontal** to place a new guide, then hover the mouse over it and drag it to the desired position.



Figure 171

6.4.11.12 THE POSITIONING TAB

This final tabbed panel gives you a little more room in the **composition window**, and also provides a convenient **Reset** button for keyframes. As well, it gives access to some 'full page scope' interactive tools like Crop and Smoothing (these correspond to the tools by the same name discussed later in the main Controls section, so we'll leave coverage until then.



Figure 172

6.4.11.13 PRE-BUILT TEXT PAGES

The **Templates** folder is found by clicking the Titles **Hotlist** button. Here you will find more than 170 professionally designed CG page styles which can be modified for use in any project. The changes are saved as part of the project, but if you wish to re-use this page, you can hold down the Ctrl key and drag a copy of that .cg page into a **Media Bin** folder. This copy can then be quickly re-used in other projects.

NOTE: These templates are not compatible with the Live Production Text feature. However, they can be rendered and then added to a DDR for use with the Overlay feature. In some cases, you may wish to use the Render> TriCaster Overlay (avi with alpha) option to retain transparency.

YOUR OWN CUSTOM TEMPLATES

To save any of these pages, navigate to the Media folder you wish to store it, and Ctrl-drag a copy of it from the project into the folder. You may rename this VT Data file if you wish as a *.cg page for later use.

6.4.11.14 CONTROLS

The **Controls Tab** serves several purposes: animating, rotating, sizing, cropping, adding shadows and edges, keying, and color correcting video layers, as well as editing titles and tweaking audio.

The lower pane of **Controls** hosts a long list of attributes you can modify and animate. The list shown will depend on what sort of item is currently selected in the editor.

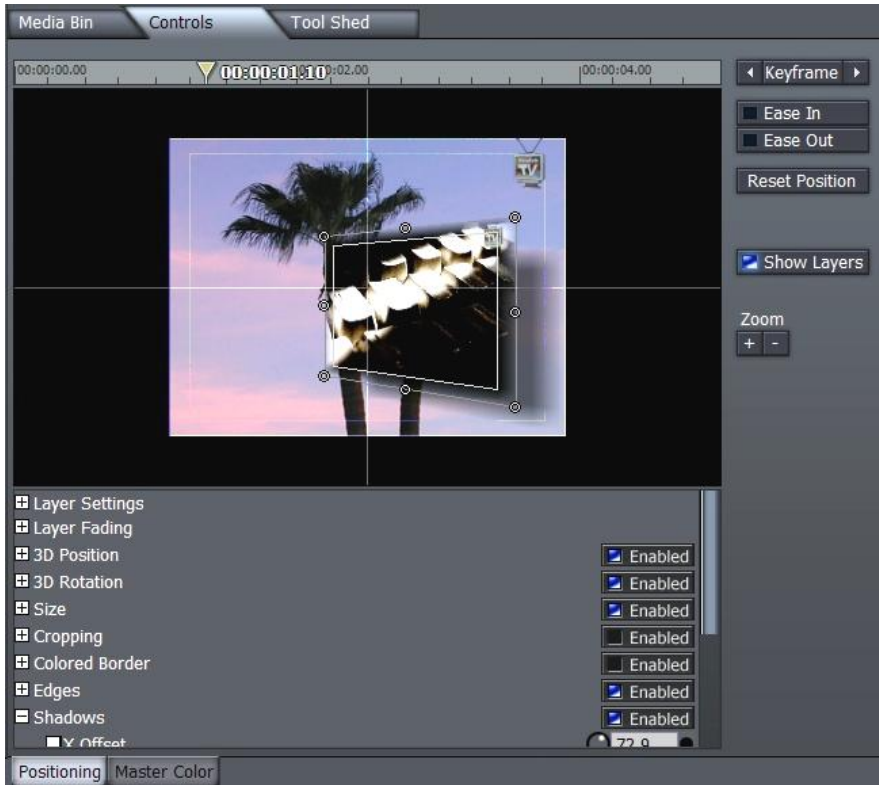

Figure 173

The options here are endless, and in some case the best way to become familiar with them is simply to select a clip and start experimenting. You'll be astounded at the realtime power at your fingertips! We'll look at some of the more important features next.

Before we get into some of the truly exciting options provided in **Controls**, let's spend a few minutes on the **Layer Settings** section. As intuitive as TriCaster's editor is, there are so many file formats that it may 'guess' wrong at times when you add a clip; or you may want to tweak slow motion speed precisely. These important settings are in this section.

6.4.11.15 LAYER SETTINGS

Select a clip, and click the [+] at left in **Controls** to expand **Layer Settings**.

Aspect Ratio

The Aspect Ratio menu provides a large array of Image Aspect presets. By default, it is set to Auto. The Auto mode essentially instructs the editor to examine the current clip, and conform it to the project Image Aspect, without sacrificing its own proportions.

For example, **Auto** mode (usually) recognizes that the High Definition 16:9 video clip you loaded into your (Standard Definition 4:3) project has to be scaled down, but that you do not want the image to appear distorted. Aspect and Size are automatically balanced, with the result that the clip is correctly displayed as letter-boxed. If you wish to override this default Auto decision, you could simply raise the automatically chosen Size value until the clip fills the frame horizontally, up-scaling even further to produce a cropped full-frame view on the Output.

Hint: In a few cases, the file format of the clip may lack sufficient information to automatically discern the proper Image Aspect. In such cases, you can manually select something suitable from the long list of presets provided.

FIELDING

Standard Definition video is almost always interlaced, comprised of two separate video fields. TriCaster's editor will generally auto-select the correct field dominance when you add clips. When necessary you can choose a different field order manually using this setting.

QUALITY

When you are positioning and/or scaling an image asset, this setting permits you to raise the quality of the algorithm applied when you see a need to do so. In High Quality, full interpolation and sub pixel correction is performed (taking about 30% more CPU power than low quality.)

IMAGE SUPER-SAMPLING

ISS maximizes image fidelity during scaling, and is off by default because of the increased processing it demands. Enable it only if you notice any minor problems at the edge of clips (CG objects in particular) when the source is being dramatically scaled (ISS has no effect on clips sized at 100%.)

HINT: Use High Quality sparingly. The result often looks just fine, especially when a clip has not had its position animated.

BG COLOR

If the clip is displayed at less than project size, the default background in non-image areas of the Output is black. BG Color allows you to specify another color (a useful ability when producing a photomontage, for example.) Click the color swatch next to BG Color to open a Color Picker, or use the RGB knobs or direct entry fields to set the BG color. You can also right-click in the box to activate the Eyedropper tool, and then select a color from anywhere on the desktop.

Hint: When you right click and drag from the color swatch to anywhere in the interface, the color in the swatch updates as you move the cursor. The actual color selection is only made when you release the mouse button.

(Before trying this, use the Size tool, to change the clip Size to 70%, so you can view the results of your experiments.)

HINT: Remember that holding the Ctrl key when you twist knobs or drag sliders enables 10X accuracy.

Like most Control options, color settings can be keyframed over the duration of the clip. So you could start out with a white frame, turn it to red in the middle of the clip, and by the end, make it green.

PLAYBACK SPEED

This keyframeable value provides the ability to ramp the speed up or down over time. For example, you can start a clip playing at full speed, gradually slow it down to the mid-point, then ramp it up to full speed again at the end.

BG RENDER

This forces the section of the timeline occupied by this clip to background render. This can be useful if a particularly complicated section of the project tends to stutter when played back.

NON ITU-R BT601 COLOR

This is a per-clip control for modifying the default pedestal setting from the project standard.

6.4.11.16 ANIMATING

We discussed several examples using the **Positioning** panel to keyframe values back in Section 3.4, and again under the heading **Animating Titles** in Section 6.4.11.5 of this chapter (where we also considered **Ease In and Out**.) You may wish to review those examples to refresh your knowledge.

6.4.12 AUDIO

If you select an **Audio** file in the workspace, **Controls** presents a different interface to adjust audio levels and balance.

All control parameters can be animated by using the **Keyframe** button, scrubbing to the next point of audio or video, and setting the next keyframe (including the **Stereo Balance** slider.)

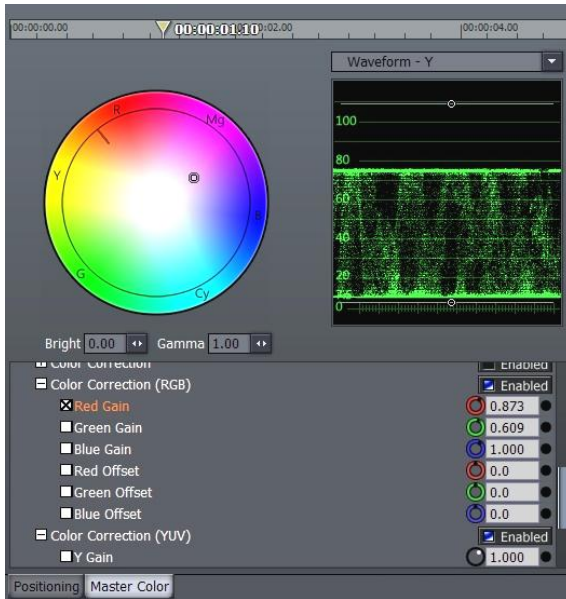

Figure 174

6.4.13 MASTER COLOR

One section of **Controls** that we haven't looked at yet is the **Master Color** panel. Click that tab (next to the Positioner tab at the bottom of Controls.)

The main **Color Correction** section of the Control List at left breaks out to reveal many sub-sections. These include **Color Correction**, **Color Correction (RGB)**, and **Color Correction (YUV)**.



In addition, the panel above now displays an interactive **RGB Color Wheel** and (by default) **Waveform** luminance (Y value) scope.

Before we consider these interactive controls, please expand the **Color Correction** sub-section, and examine the **White Balance** controls. These can be very handy, and are easy to use.

Figure 175

6.4.14 WHITE BALANCE

If every light source on the planet were the same color, your camera wouldn't need any white balance controls. And if you had perfect memory, neither would your edit suite. But that's not the kind of world we live in, so these **White Balance** controls are pretty nice to have.

The three-color channels the tool works on are listed separately, and the values for each can be manually edited if you wish. That's a tedious approach though, so all you really need to do is right-click the color swatch provided, and either:

- click the spot in the image that is as close to white already as it gets
- or ...
- keep pressing the mouse button as you glide around the image, and watch both the color swatch and correction update in realtime as you do so -- until you find a happy combination.

The next section of the simple Color Correction group holds familiar tools:

Brightness - adjusts the luminance (lightness and darkness) of the video signal.

Contrast - adjusts the levels of gray in the signal (which co-incidentally also affects the brightness and saturation of an image.)

Saturation - refers to the intensity of color in the video signal. Low saturated pictures look gray, while overly saturated images show colors that bloom to the point of smearing.

Hue - adjusts the relative phase of color and works on the principle of a color wheel. As you rotate the knob either way, you cycle through the colors. The functional range is between 0 and 360.

Gamma - part brightness and part contrast, when applied, Gamma can improve the contrast of the mid-range of an image's tones, without damaging either its lightest and darkest values. The net result can be a more dynamic image, literally.

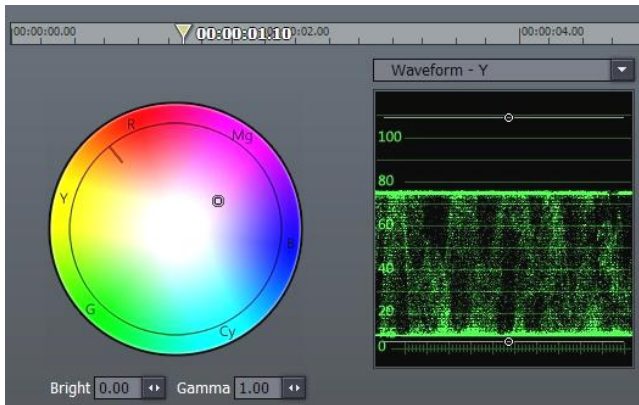

Figure 176

Before considering the rest of the tools in the **Color Correction** section, we need to pause and familiarize ourselves with the features of the **Master Color** tabbed panel. This pane features a standard RGB color wheel on the left, and a Waveform monitor displaying the selected clip's Luminance levels (represented as the Y value in YUV color space) at right

Let's watch how this panel interacts with and displays the various color settings in the Tree listing to the left.

6.4.15 COLOR CORRECTION — RGB/YUV

Expand the **Color Correction (RGB)** group. Drag your cursor around in the Color Wheel and watch how this affects the values shown in the **Red, Green and Blue Gain** fields in the settings pane. As you might expect, the converse is also true. Adjusting the **Brightness** and **Gamma** settings trigger matching changes in the corresponding numeric fields in the Master Color pane, too.

The **Waveform** display is also an interactive control panel. Drag your mouse over it, please. As you move close to the white lines indicating your pedestal (0 or 7.5 IRE) and the 100 or 110 IRE established as maximum, the cursor displays "Y Gain" - dragging will adjust the corresponding value in **Color Correction (YUV)**. Dragging in the middle of the range adjusts the **Y Offset**.

Click and hold the drop-down menu directly above the **Waveform** display, and choose **Waveform YUV**. Now you have the same ability to adjust each of those values (discussed in more depth below) graphically

too, with realtime results showed on the Output monitor, and scope-accurate information at your fingertips!

The **Waveform RGB** option mimics this ability using RGB color values in place of YUV.

With respect to the **Vectorscope**, dragging inside the scope moves the cross-hairs, resulting in either a **U Offset** (drag horizontally), **V Offset** (drag vertically) or **Hue** shift (drag outside the cross-hairs to rotate the hue through the color spectrum.) Let's get back to the **Control** settings pane now, and discuss the meaning of the Color Correction values we've been tweaking:

Gain is similar to **Saturation**, except that when you adjust the **Gain**, you increase or decrease the saturation of just one color channel of the video signal. Adjustments affect other colors in the image only to the degree that they are composed of it. For example, if you look on the 3-Band color Vectorscope, you will see that modifying Red Gain affects Red, Magenta and Yellow.

Offset, while similar, affects every color in the video signal, even black. Rotate clockwise to increase red saturation, counter-clockwise to decrease it. Adjusting Red Offset shifts the entire signal diagonally in the Vectorscope.

6.5 TOOL SHED

There are many repetitive tasks when creating a video, and if you find yourself drifting from the fun of creation and getting burdened by click...drag, click...drag, it's time to stop and take a look within the **Tool Shed** tab. This collection of ready-to-use tools will help you create faster, with more effort spent on telling the story, and less time devoted to wondering how to do it.

This is something that merits exploration, and should prove to be quite fun! Better yet, there is an assistant just a button away. If you would like more information on any of the tools, select that tool and click the **Help** button.

Most **Tool Shed** functions follow a very simple recipe: Select a clip (or a series of clips) choose a tool and click Perform. There are far too many tools in the **Tool Shed** to explain all of them; fortunately, many are self-explanatory and so simple to use that you'll want to make sure the client isn't peeking over your shoulder when you click!

Let's have a peek at a representative sampling:

6.5.1.1 DEFAULT PRESETS

Click the **Tool Shed** tab, and then click the [+] button to the left of the label Presets in the lower section of the panel to reveal two options: **Default Presets** and **User Presets**.

Choose **Default Presets**, by clicking on it, and the upper panel will fill to overflowing with a list of tools you can use. Roughly half the entries in this group are **Color Filters**.

To demonstrate, highlight a clip in the editor, and click the **Color Filter - Sepia** entry.

Click the **Perform** button and your selection is instantly applied (no downtime rendering effects using your realtime TriCaster!)

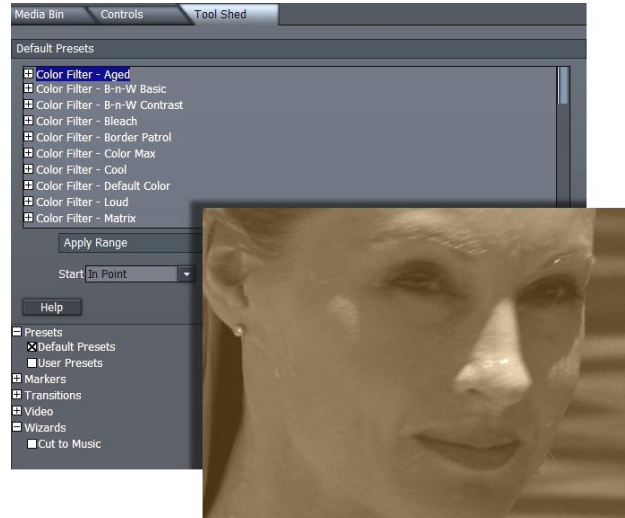

Figure 177

Other tools in the Default Preset listing perform elaborate wipes, as well as various common scaling routines (the latter are great time savers when you have to modify many clips at once.)

The **Start** and **End** menus permit you to process just part of the clip. **Mode** is relevant for **Tool Shed** effects that have changing values over time, controlled by keyframes. If your current clip is longer or shorter than allowed for in the original effect, you can **Preserve** the original timing from the start of the clip, or at its end – but more often than not you may want to **Scale** the keyframes to perfectly match the new duration.

6.5.1.2 USER PRESETS

The User Preset section is worth its weight in gold (using the heaviest pixels you can find!) It works like this: Select a clip, and use the **Controls** pane to do anything you like to it – set up custom color correction, transparency, a 3D rotation ... anything you can think of!

Click **User Presets** in the **Tool Shed**, and then click the **New** button. Supply a name in the text field that pops up, and press Enter on the keyboard. Your new custom preset is added, and can be used over and over again, or be applied to many clips at once -- just like the **Default Presets**!

Note: in both sections (Default and User), you can selectively enable or disable specific attributes in the effect settings. Click the [+] button next to an item (such as Layer Settings) to toggle its application in the current effect. (it's useful to know, too, that you can create presets retaining only user-modified attributes by first holding down the Shift key when you press New.)

6.5.1.3 MARKERS

Timeline markers (discussed earlier in Section 6.4.7, Markers) serve many purposes. The tools in this section permit you to add, edit and quantize marker positions in various convenient ways.

6.5.1.4 TRANSITIONS

The Transitions group in the Tool Shed lets you add Transitions to a few clips or you entire project at once. You can also adjust the timing of existing Transitions, or replace them with a different one.

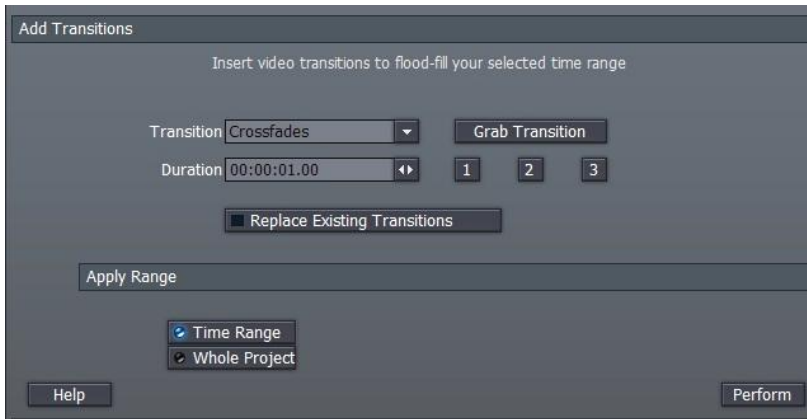

Figure 178

The options are easy to understand, and **Help** provides reminders if necessary.

6.5.1.5 VIDEO

The Video group provides some wonderful tool. You can reset clips to news lengths, **Stabilize** shaky video, and much more. Let's consider an example using the **Match Colors** wizard.

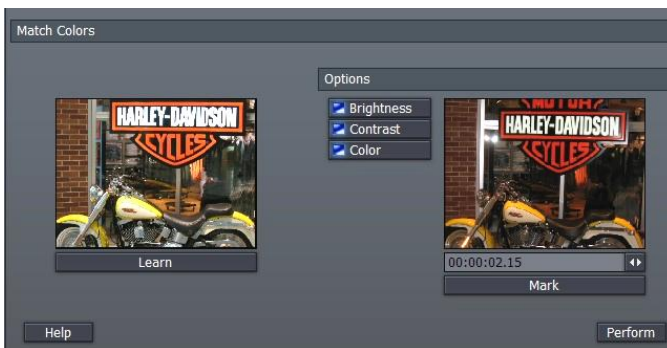

Figure 179

In this case, we have two similar clips, but one was underexposed.

To correct the problem, we select the correctly lit shot, and click **Learn**. Then select the second clip (the poorly lit one) and click **Perform**. It's that easy!

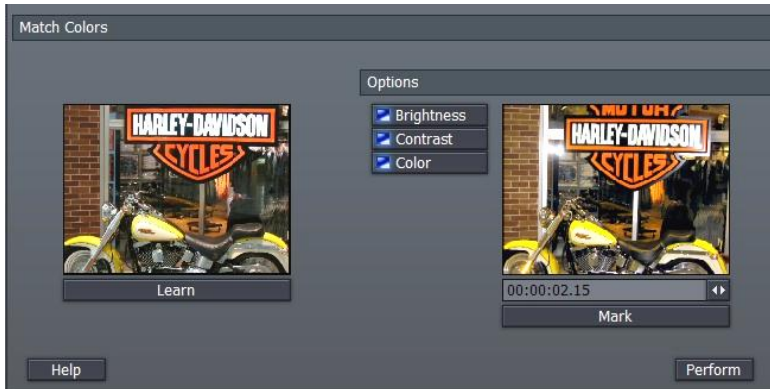

Figure 180

The image above shows the result. In the **Options** section of the panel, you can individually toggle the effect's operation on **Brightness, Contrast and Color**.

6.5.1.6 WIZARDS

In the Wizards group, you will find the **Cut to Music** item. This is a wonderful tool, and can make you look like an MTV pro with a few clicks!

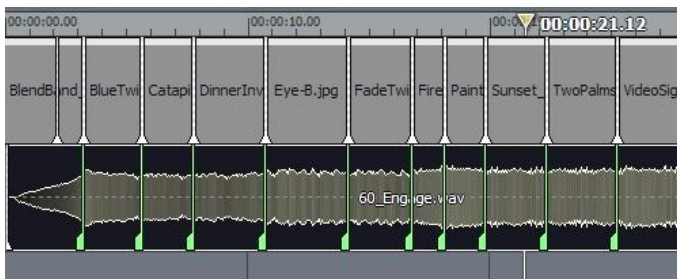

Figure 181

An example of its use might be a corporate photo montage. You have a folder of digital photos from an event to use. You drop them all into the project, where they assume the default 5 second duration assigned automatically in TriCaster.

Next, you drag the music file you want to use for the project onto the timeline, and select it. Click the Play button, and as you listen to the music, press the m key on the keyboard at each main beat you hear. When you're done, simply click the Perform button in the Tool Shed, and your clips are all perfectly trimmed!

Hint: for slower music, you may want to use the Tool Shed's Video tools to change the default length of all your photos or clips to something longer first. Afterward, you can use the Tool Shed again to add transitions at each cut, too!

See why they call it a "Wizard?" 😊

7 EDIT TEXT

To reiterate what was said earlier (in the Quick Start section), the Edit Text panel provides deep professional character generation facilities. You can use it to design and manage great looking still and animated text and graphics for your productions (whether Live or Edit Media projects.)

For live production purposes, Edit Text panel creations can be utilized as **Overlays**, supplied by the **DDR** or **Picture** modules, or as *custom templates* for the **Text** module. Alternatively, you can even create a custom **LiveSet** for use in **Input Setup**. And of course, exported title/cg pages can be used as graphic elements in **Edit Media** projects too.



Figure 182

7.1 INTERFACE LAYOUT

The main panel is dominated by the large, central **Work Area**, which provides an interactive display of the current project page. The column to its left is a **Tool Panel** for creating and editing visual elements, including text. The **Motion Panel** located just below the Work Area permits you to create animated scrolls or crawls. Just beneath the Motion Panel is a tabbed **Control Panel** giving complete control over attributes of text and graphic objects. Finally, a column down the right side of the Work Area provides multi-page management of your project, and various file **Load**, **Save** and **Export** functions.

7.2 PROJECT PAGE MANAGEMENT

Edit Text projects consist of one or more *pages*. If you create one graphic for a title, another for a station ID, and another of scrolling credits, each of these exists as a separate project page. Completed pages may be exported (using **Save As**) image or animation files, as Custom Templates, or even as LiveSets.

7.2.1 THE PAGES PANEL

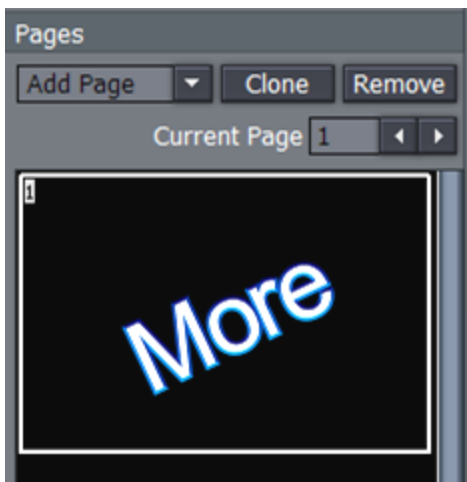

The **Pages Panel** at the right of the **Work Area** displays a thumbnail for each page in the current project, and provides basic page management tools. A new project will show one (empty) page.

Just above the thumbnail display column is the **Current Page** selector. You can quickly jump to a certain page in your project by entering the page number in the **Page** field. Or you can cycle up or down through the pages by clicking on the neighboring arrow buttons.

Clicking **Clone** copies the page represented by the currently highlighted thumbnail, pasting the copy below that page.

Figure 183

Hint: Clone permits you to quickly and easily ensure pages conform to a particular graphic theme or format – just Clone an adequate number for you needs, then modify them individually.

Clicking **Remove** deletes the currently selected page from the project (careful, there is no Undo for this action.)

7.2.1.1 ADD PAGE

You click the arrow button beside **Add Page** to insert another page into your project (new pages are added under the current page.)

The drop-down menu reveals a number of types of pages you can add:

The uppermost choices represent new blank pages of various types.

Hint: You can also quickly add blank pages simply by clicking repeatedly in an empty black area of the thumbnail column – each click adds one empty page.

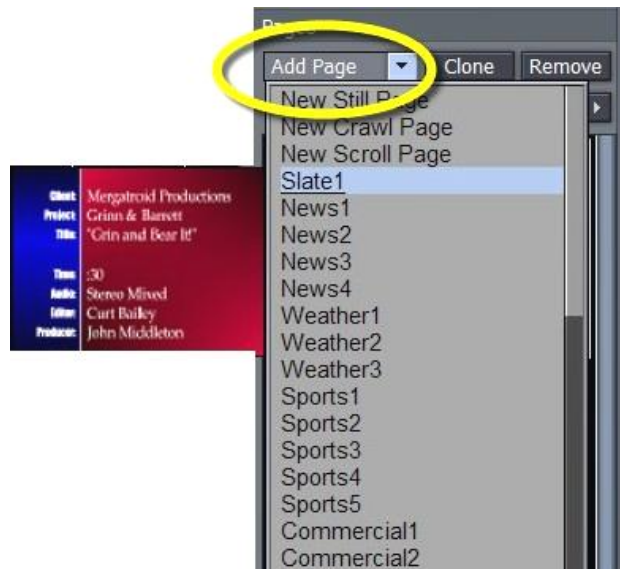

Figure 184

Below this is a long list of professionally designed templates, ready and waiting for your modifications. As you scroll over the entries, a fly out thumbnail representation appears to make choosing something just right for your needs easy.

Hint: Another selection in the Add Pages menu permits you to “Add Page to Templates List.” This lets you store the currently highlighted pages as templates, for quick access and consistent styling using templates of your own design.

7.2.2 PROJECT

The **Project** panel contains project and page file management tools. Projects and (editable pages) are stored as *.cg files. Clicking **New** clears the current project, and opens a new blank one.

Load also clears the current project, normally replacing it with one you have previously saved as a .cg file.

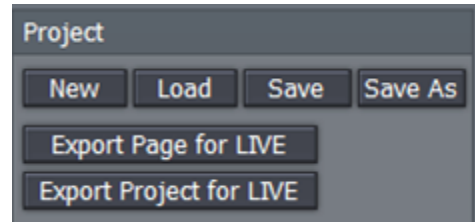

Figure 185

You can change the file suffix filter in the file requester to show files ending in .txt, then import long lists of textual data prepared in standard ASCII text format and saved as a .txt file. This process is also detailed in Section 7.5.5.1, Import Text,

The **Save** button stores all pages of the current project at a location you choose using the File Requester provided. Re-saving an existing project file occurs instantly. To save a new version of such a file under a new name, click **Save As**.

7.2.2.1 EXPORT OPTIONS

Export Page for LIVE and **Export Project for LIVE** variously convert the highlighted page or project for application in your LIVE productions.

Exported CG pages can be employed as **LiveSets** from **Input Setup**, as **Text Templates** from the LIVE Production **Text** module, or as images or animations from the **DDR** (or **Pictures** – stills only) playlist. In the last two cases, if the page(s) contain transparent areas, the transparency will be retained if you place them over your program stream using **Overlay**.

Any **Still** (no motion) pages created by the Export functions are automatically inserted into the list of templates available for the Text module (Text Page group), as well as being listed as individual **Shots** in the **LiveSet** menu when you select CG Designer as the **Scene**.

*Note: Clicking one of the Export buttons presents a dialogue which allows you to choose whether to **Append** the new entries or to completely **Replace** the current list with your Edit Text selection(s.)*

Motion pages (scrolls or crawls) are exported as AVI files with alpha channel. These page types are *not* available in LiveSet or as Templates, but can be added to the DDR playlist (you will find Edit Text exports in D:/Media/CGs.) Again, when there are transparent areas in the animation, these will be respected if applied via the **Overlay** module.

7.3 THE TOOL PANEL

The Tool Panel situated left of the Work Area provides the basic tools for creating both text and graphic elements of your title page compositions, establish their relationships to one another if any, and set their primary attributes.

7.3.1 TEXT AND DRAWING

T (Text)

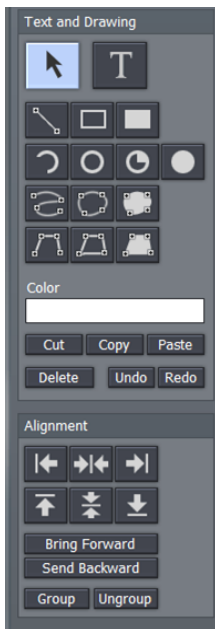

Click on the T (Text) button to activate the text function. Before you enter text, this button must be highlighted. Click in the Work Area and an I-beam icon starts blinking. This is your Work Area cursor. When you type, the I-beam is the insert point for the text. You can move the I-beam anywhere on the Work Area by clicking it with your mouse and dragging it around or just clicking your mouse on another spot in the Work Area.

To edit the characters of any existing text, click your cursor anywhere on the line of text, and drag your mouse to select letters or whole words (selected character will be highlighted.)

*Hint: Use the **End** and **Home** keys on your keyboard to navigate to the beginning and end of text lines. If you mistyped, you can use the **Backspace** key to erase or the keyboard **arrow** keys to go back or forth on the line or up and down between lines.*

Figure 186

Arrow (Selection)

Clicking on the **Arrow** button activates the Selection tool (and switches off the Text tool). This selects the whole line, not just parts of it. If you have just typed something in, clicking the Arrow will create a box around what you typed. Select the line by clicking anywhere on it.

When you roll your mouse over the box, the cursor changes form. When it becomes a two-headed arrow, you can click to grab an edge of the box and drag it in or out to resize the text. When the cursor sprouts four arrowheads, you can click and grab the whole box to move it around the Work Area. Hold down the Shift key over a corner of a selected object and a curved arrow cursor indicates you may now drag to rotate it.

7.3.1.1 GRAPHIC SHAPE TOOLS

The area immediately below the Arrow and T(Text) buttons is home to a number of tools used to create shapes. Each shape is initially a separate graphic object.

The tools are very easy to use, and just as easy to edit at any time after their creation, whether simply to adjust their position, or to add or modify much more elaborate treatments.

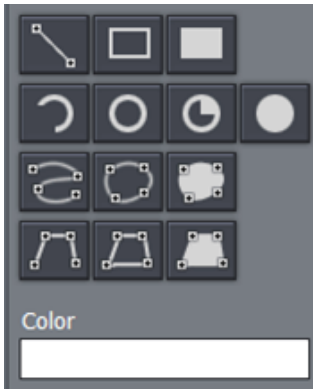

For the most part, shapes are easily created by clicking one of the buttons, and dragging the cursor in the Work Area. The shape responds interactively to your movements, and is created when you release the mouse button.

Figure 187

- **Line** - To make a straight line, you simply click in the Work Area where you want the line to begin and then drag the mouse to where you want the line to end.
- **Rectangle** - The Rectangle button creates outlines of four-sided objects.
- **Filled Rectangle** - This tool works just like the Rectangle tool except it fills in shape with the same color as the outline.

- **Arc** - In the second row of Drawing Tools are variations of ovals. With the first, you can create segments of arcs. Click the mouse in the Work Area and drag to establish the radius of the arc, releasing the button when you are happy. Then click and drag again to define the extent of the arc. Release the button to complete it.
- **Oval** - The Oval works just like the Rectangle tool. You click and drag in the Work Area to draw out your shape.
- **Filled Arc** - The Filled Arc operation is the same as the Arc tool (see above). The only difference is that the arc created is filled in. Think of the Filled Arc as the pie chart tool.
- **Filled Oval** - This tool works like the Filled Rectangle.

- **Spline** – This tool and its siblings create freeform spline curve shapes. Click in the Work Area and release the mouse to establish the starting point. Move to another spot on the screen and click again to establish a second node through which the spline will pass. Continue to add nodes until you are satisfied, then double-click to end the curve.
- **Closed Spline** - The technique for the Closed Spline is similar to the Spline: click in the Work Area, release the mouse, move to the next spot and click again, etc... With this tool though, nodes are automatically connected to the first (anchor) point to create an enclosed object. When you're finished, simply double-click.
- **Closed Filled Spline** - This tool works just like the Closed Spline tool except it fills in shape with the same color as the outline.

- **Polygonal Line** - This tool functions like the Spline except it doesn't create a curve between the nodes. You click in the Work Area to establish your anchor point, release the mouse and move to your next spot, and click to create a node. A straight line will connect the two points. Move and click again and a line will connect this point with the previous one. With this tool, a sharp angle is maintained at the intersection of the lines. You double-click at the last point to finish.
- **Polygon** - This tool works like the Polygonal Line, except as soon as you create the first node, it's connected to the anchor point, automatically creating an enclosed object.
- **Filled Polygon** - This tool works just like the Polygon tool except it fills in shape with the same color as the outline.



Figure 188

Color - The large color well below the drawing tools permits you to set a base color for the objects you create using the tools. Left click it to open the Color Picker panel, or right click and drag to use an eye dropper cursor to pick a color from the screen.

*Note: Extensive control over color is provided in the **Color** section of the tabbed **Control Panel** discussed a bit further on in this chapter.*

7.3.1.2 OBJECT MANAGEMENT

Completing this section are essential basic editing tools: **Cut**, **Copy**, **Paste**, **Delete**, **Undo**, and **Redo**. The traditional Windows keyboard shortcuts also work:

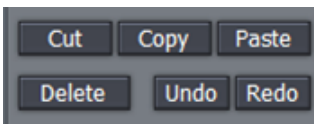

Figure 189

- Cut — **Ctrl + x**
- Copy — **Ctrl + c**
- Paste — **Ctrl + v**
- Delete — **Delete** key
- Undo — **Ctrl + z**
- Redo — **Ctrl + y**

7.3.2 ALIGNMENT

The alignment panel permits quick and easy positioning and re-ordering of objects on the Work Area.

7.3.2.1 HORIZONTAL JUSTIFICATION

The top row of buttons in this section control horizontal justification buttons, aligning text as are commonly found in word processing programs.



Left Justify - aligns your text to begin just inside the left edge of the Text Safe Area

Center - aligns the center of the line(s) with the center of the Text Safe Area.

Right Justify - aligns your text so the end of the line(s) is just inside the right edge of the Text Safe Area.

Figure 190

7.3.2.2 VERTICAL JUSTIFICATION

Each of the buttons in the next row justifies your text within the vertical Safe Text area of the screen.

Top - aligns your text just below the upper limit of the Text Safe Area.

Center - centers your text vertically in the Text Safe Area.

Bottom - aligns your text just above the lower limit of the Text Safe Area.

7.3.2.3 DEPTH CONTROL

Text and objects in the Work Area which occupy the same space are normally displayed in the order created – first items to the rear, as it were, with newer object in front. The depth controls in this section

permit you to modify this order. Select an object (or line of text) and click once to move one step relative to other objects.

Bring Forward – move the selected item forward

Send Backward – move the selected item back

*Note: The **Layer** section of the tabbed **Control Panel** discussed a bit further on in this chapter provides an alternative (and often more convenient method) of re-ordering objects and text.*

7.3.2.4 GROUP / UNGROUP

Even though each line of text and graphic object is really a separate entity, you can select multiple lines and **Group** them together to respond to modifications in unison.

The **UnGroup** button undoes the union. Hold down the Ctrl key while clicking multiple items or lines of text and press the Group button. The bounding boxes are now replaced by a single bounding box. Hit UnGroup again, and the lines become separate entities once more.

7.4 THE MOTION PANEL

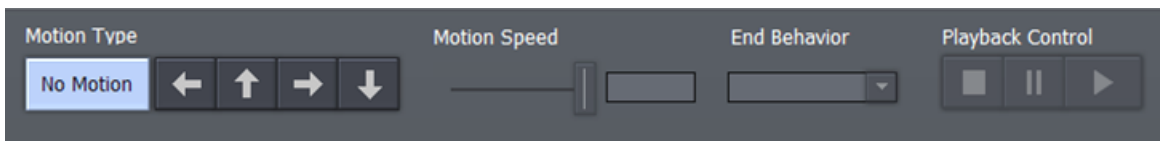

Figure 191

The **Motion Panel** contains the tools to create both scrolls and crawls. This is where you control the direction, speed and behaviors of your crawls and scrolls.

The **No Motion** button and **Direction arrows** are self-explanatory. If you want a text **crawl** from left to right, pick the right pointing arrow. For a **scroll** moving up, choose the up arrow, etc.

7.4.1 SPEED CONTROL

In the **Motion Speed** field, choose a specific rate of motion in units of ‘pixels per frame.’

Fun with math: For a text crawl across an NTSC format screen, knowing that the screen is 720 pixels and there are roughly 30 frames per second, you can readily work out a suitable value. To have an object or text item crawl from one side to the other in four seconds, 720 divided by 120 (30 frames per each of 4 second) equals 6.

If motion pages move too quickly, motion may not appear smooth. A common preference is for a line of text to take about seven seconds to travel from the bottom of the screen to the top. You may wish to test the speed out on a TV monitor to see if it suits you.

7.4.2 END BEHAVIOR

The **End Behavior** setting in the **Motion Panel** determines what happens when an animated page runs its full course.

- **Over** tells the CG to scroll or crawl the page once, and then stop when the page has left the screen.
- **Stop** tells the CG to scroll or crawl the page once and then to hold on the last line of text.
- **Loop** tells the CG to loop the page continuously.
- **Loop + Frame** tells the CG to loop the page continuously and to place a blank frame between each loop iteration.

7.5 CONTROL PANEL TABS



Figure 192

Near the bottom of the screen (beneath the Motion Panel) is the multi-tab **Control Panel**. The individual panels provide precise command of countless text and graphic object attributes, organization and management.

7.5.1 VIEW

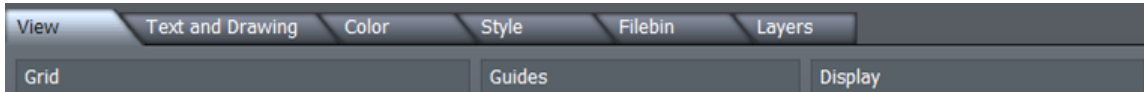
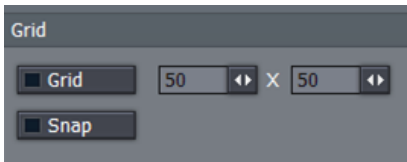

Figure 193

The View tab reveals three sections, **Grid**, **Guides** and **Display**. These all add one or another type of overlay to the **Work Area** above, as an aid to composing your graphic and text pages on. As you would expect, none of the overlay elements appear in the final output.

GRID



Define a grid to help you align objects on the Work Area in specific arrangements.

The two numeric entry fields with associated mini-sliders adjust the width and height of cells in the grid.

Figure 194

The **Grid** switch toggles the grid overlay on/off. Enabling **Snap** effectively makes the lines of the grid *somewhat* magnetic - you are not restricted to placing items exclusively along the grid lines, but the cursor is drawn toward them, making it easy to do so if you wish.

GUIDES

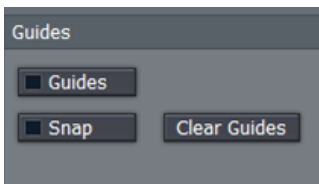

This feature is somewhat similar, in that it offers overlaid lines and a similar Snap feature. However, rather than displaying a full grid, you define where the lines will go – add just one guide line, or as many as you like.

To add a Guide, **Rulers** must be enabled in the Display section. Click in the calibrated ruler display, (horizontal or vertical), and drag the cursor

Figure 195

across the Work Area. Release the mouse button when the new Guide is positioned where you want it to go. If you hover the cursor above a Guide, it becomes a double-headed arrow that you can drag change the Guide's position.

Use **Clear Guides** to remove all existing Guides from the screen.

DISPLAY

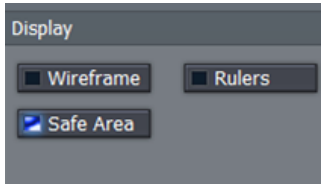

Traditional television displays usually crop the image area of video somewhat.

For this reason, it's customary to allow a certain amount of 'safe area' on the margins of the screen – to make sure that important text displays or action are not inadvertently cut off for viewers.

Figure 196

The **Safe Area** switch in the Display panel overlays two bounding boxes on the Work Area. These lines make it easy for you to create your title pages with these 'overscan' limitations in mind. The inner rectangle outlines the Text Safe area, while the outer one is considered Action Safe.

For very complex pages, it can be useful to enable the **Wireframe** switch. While enabled, this removes opaque color from objects on the Work Area window, leaving only an outline through which other items can be seen.

Finally, the **Rulers** option provides another level of precision when preparing your title pages by adding calibrated scales to the display. (And, as noted a moment ago, you add Guides to the work area using the Rulers.)

7.5.2 TEXT AND DRAWING

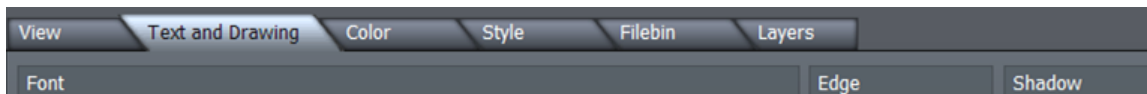

Figure 197

This tab provides primary control over all text and graphic object attributes.

7.5.2.1 FONT AND ORIENTATION

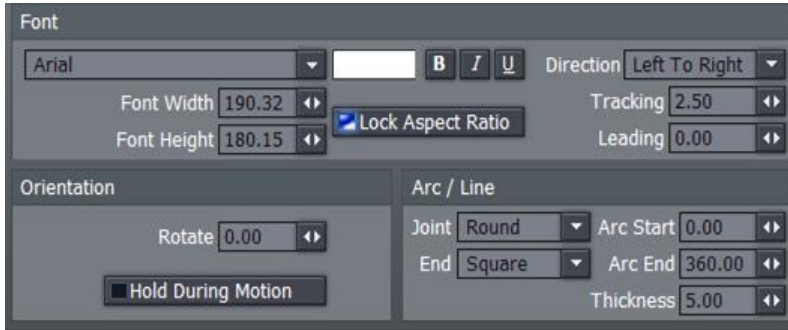

Figure 198

FONT

The drop-down **Font** menu allows you to choose from your installed typefaces. **Bold**, **Italic**, and **Underline** buttons are to its right, along with another *basic* face color well.

The **Width** and **Height** controls are locked proportionally when the neighboring **Lock Aspect Ratio** control is lit up. **Rotate** adjusts the exact degree of rotation (on the Z axis.)

Tracking adjusts the amount of space between neighboring pairs of letters.

Hint: You can also adjust tracking interactively in the Work Area. Place the cursor between letters and, while holding down the Alt key, use the arrow keys to add or reduce spacing.

Leading adjusts the amount of vertical space between text lines. Multi-select the lines you wish to adjust using CTRL+click (or by dragging a rectangle around them in the preview window), and raise or lower the Leading value to suit your need.

ORIENTATION

Rotate changes the orientation of text and drawing objects. **Hold During Motion**, when enabled, ensures that the selected object does not move as an element within **Scroll** or **Crawl** pages. **Do Not Render** prevents the image from being displayed as part of the page when displayed or rendered.

ARC/LINE

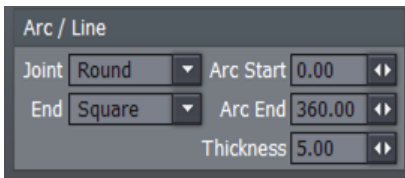

The **Joint** menu options affect way corners of a drawn CG object are created – choose from **Round**, **Bevel**, or **Square**.

Similarly, the **End** menu selection determines whether the ends of a line object terminate in a **Square**, **Round**, or **Point**.

Figure 199

Arc Start and **End** values permit great precision for **Arc** and **Filled Arc** objects, and the **Thickness** value is pretty much self-explanatory.

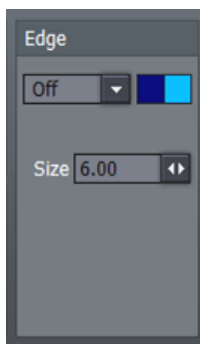

Figure 200

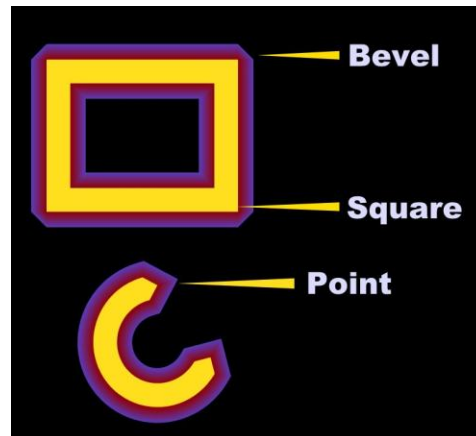

Figure 201

EDGE

Edge refers to a two-tone border that conforms to character or object shape. The way corners are painted is controlled by the drop-down menu – options are **Round**, **Square**, or **Bevel**.

The two boxes to the right of the menu are where you choose the colors for the inside and outside edges of the border applied around your objects. Inside color is the box on the left, outside color is on the right.

Click in the box to bring up the Color Picker panel or right-click in the box to activate the Eyedropper tool to easily copy an existing color from the work area.

SHADOW

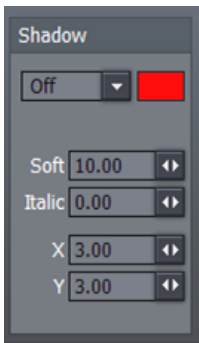

Shadow options include **Cast**, **Drop**, and **Soft** (the numeric **Soft** setting is only relevant to the latter.)

The **Italic** setting permits you to shear the Shadow independent of the 'shadow-casting' object, and the **X** and **Y** fields control the amount of offset for the shadow.

Figure 202

7.5.3 THE COLOR TAB

The Color tab provides the control over characteristics for coloring and texturing objects, including text.

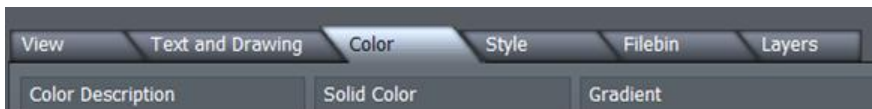
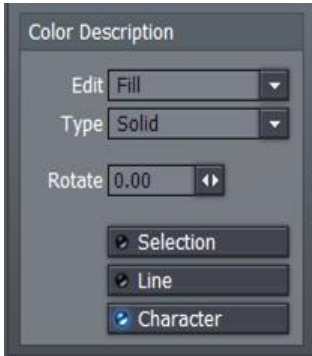

Figure 203

7.5.3.1 COLOR DESCRIPTION



Use the **Edit** menu to specify which aspect of a text line or graphic object you intend to modify.

There are three choices: **Fill** controls colors used in the body of the font or object. Choosing **Edge** or **Shadow** restricts modifications one of those characteristics.

Type permits you to choose between six different types of color (or image-based texture):

Figure 204

Choosing **Solid** for Type applies a single color to the surface (the one in the neighboring **Solid Color** pane). When you pick one of the middle four instead (**Linear**, **Corners**, **Angle**, or **Radial**), the current **Gradient** colors are applied. Linear applies the Gradient in a straight left-to-right pattern. Corners will apply the gradient color starting at the upper left corner diagonally, sweeping around to the bottom right. Angle applies the Gradient starting at 3 o'clock and rotating counterclockwise. Radial applies the Gradient starting at the center of the surface and emanating to the edge. **Texture** applies an image map (specified using the **Image** drop-down menu in the **Solid Color** Pane at right) to the surface.

Adjusting the **Rotate** value changes the application angle for the gradient or texture, when active.

SELECTION, LINE & CHARACTER

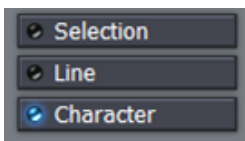

If you have multiple lines of text on a page, you can choose how the color, gradient, or texture will be applied.

Selection fits your settings to selected characters or objects (including multiple selections.) **Line** applies them independently to each line of text, while **Character** applies the texture independently to each character.

Figure 205

Note: in reality, each text line is always a separate object. If you select just part of a text line (in the Work Area while in T(Text) mode (whether by dragging the mouse or using Shift with the arrows keys), and apply different settings, the line will split into two objects to accommodate your wishes. You may want to use the Group function to permit you to continue treating the line as a single object subsequently.

7.5.3.2 THE GRADIENT PANEL

Gradients are blended ranges of color that can be applied instead of a single solid one.

GRADIENT PRESETS

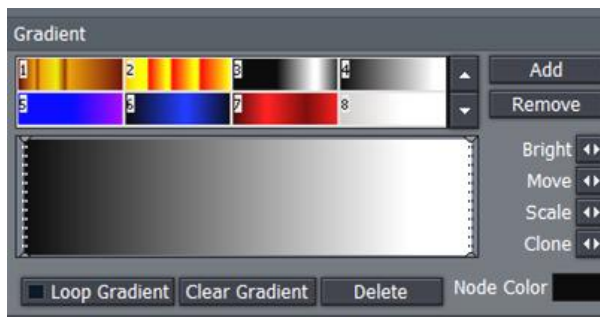

The upper section of the Gradient Panel contains a goodly number of presets, represented visually. Scroll up and down through the selections using the arrow buttons at right, and simply click a gradient you like to activate it (replacing the content of the gradient edit pane below.) Use **Add** to send the current gradient to the presets list, or **Remove** to clear a preset.

Figure 206

The dotted vertical lines in the gradient preview pane mark the nodes of specific color values that define the gradient. You can drag these left or right interactively, or select one by clicking directly on it, and **Move** it using the mini-slider control at right. The display updates immediately to show the results of the changes you make.

Add a new node by double-clicking in the gradient preview. Delete a selected node using the **Delete** button, and set its color using the **Node Color** well. You can also separately adjust the **Bright**(ness) of nodes using the mini-slider at right.

To multi-select nodes for certain operations, you can click them one at a time with the Ctrl key depressed or drag out a marquee around them right in the editor (a shaded box shows the selection zone in this case.) With one or more nodes selected, each time you drag the **Clone** slider, another set of duplicate

nodes is created. You can also clone one or more nodes by holding down Ctrl and dragging left or right in the gradient preview pane. **Scale** expands or contracts the distance between multi-selected nodes.

Clear Gradient lets you start fresh, while **Loop Gradient** allows the gradient to repeat itself, so that the color at one end loops seamlessly to the opposite end (this control has no effect when nodes exist at each end of the gradient.)

7.5.4 THE STYLE TAB



Figure 207

The **Style** tab allows you to add gorgeous and complex treatments to your text and graphic objects with a single click. It is also a great way to ensure consistency for the title slates you use in your productions!

To apply a Style preset, simply select a line of text or an object in the Work Area, and then click a representative thumbnail in the Styles pane. Create your own custom look, and add it to the Styles list using **Add**, and of course, remove those you don't care for using **Delete**.

7.5.5 THE FILEBIN

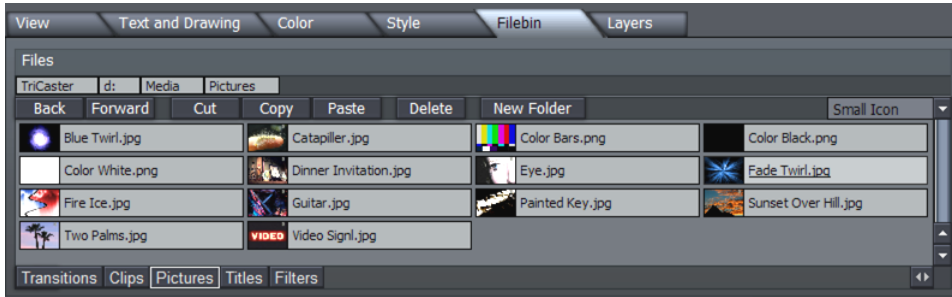

Figure 208

Above the file window is a menu with navigation and file management buttons at left, and a file icon preference menu at right (this menu gives you numerous optional views of your files)

You can simply drag image or .CG file icons right onto the **Work Area** directly from this **Filebin**. (Loading a .cg file in this fashion replaces the current project.)

7.5.5.1 IMPORT TEXT

If you drag an (ASCII) file onto the Work Area in similar fashion, the **Import Text** panel pops up.

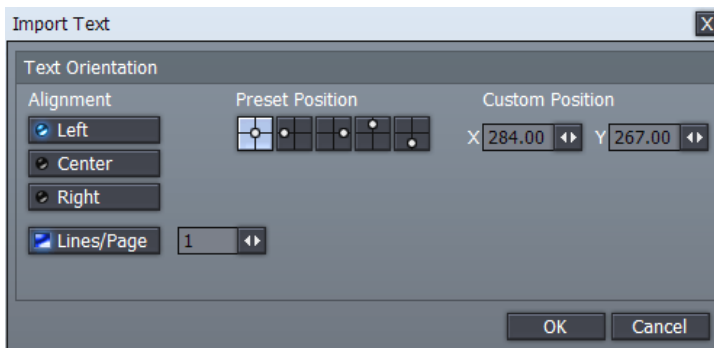
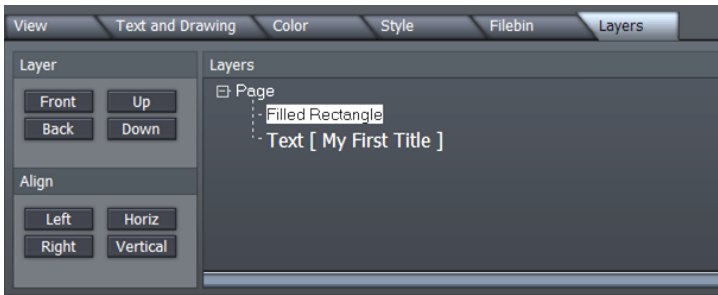

Figure 209

This panel offers numerous controls over the manner in which the lines of text in the file are treated on import, and how multiple pages will be generated as necessary for them. You can create a new page for each line of text, or form a single long page containing multiple lines. As well, you can control placement of the text on the newly created page(s) using the **Alignment**, **Preset** or **Custom Position** buttons.

7.5.6 THE LAYERS TAB



The Layers provides a convenient way to modify the depth of various text and CG objects on the Work Area, as well align objects relative to one another.

Figure 210

At times the Work Area can become rather cluttered, making it tricky to select text lines or objects directly by clicking. The final tab provides a convenient alternative. Each item in your current page is represented by an individual line in the Layers panel.

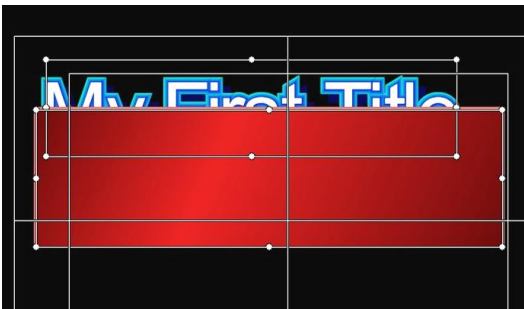

Consider the situation at left, which shows a line of text which is unfortunately occluded by a rectangle object.

Re-ordering layers is a simple matter in the Layers panel.

Figure 211

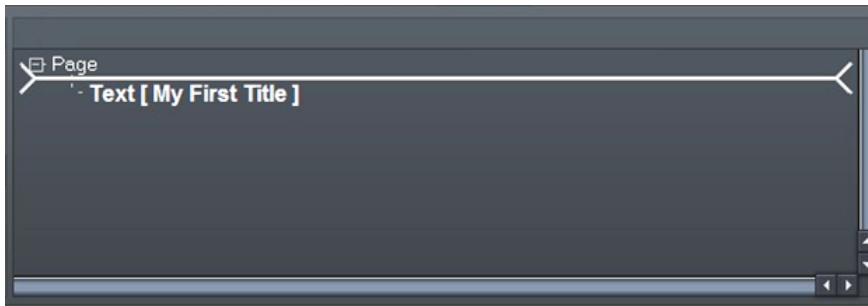

Figure 212

Simply drag the line for the rectangle above the text line with the mouse. The insertion point where the current selection will be dropped when you release the mouse is shown by a thick white line.

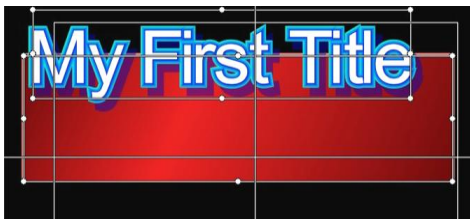

Figure 213

Objects nearest the top of the list will appear further back in the result – appearing behind objects that appear lower down in the Layers list.

Multi-select objects by dragging a box around them in the Work Area window, and click a button in the **Align** section to line them up.

The last object selected will be brightly highlighted in the Layer panel, and will be the one that other objects align to.

7.6 OPTIONS AND KEYBOARD CONTROL

An extensive list of **Keyboard Shortcuts** is available for **Text Edit** (for example, pressing Alt + F2 toggles the Safe Area overlay in the Work Area on and off.)

8 LIVEMATTE, LIVESET, LIVE ACTION!

Way back in Section 3.2.8, we introduced **LiveMatte**, TriCaster’s wonderful realtime chromakeying feature. At the end of that section, we revealed that LiveMatte was an important component of the NewTek’s revolutionary LiveSet system. LiveSet extends mundane chromakeying analogy in wonderful ways.

A really good realtime chromakey system (like LiveMatte) can seamlessly substitute a new 2D background behind the keyed foreground – typically a ‘weatherman’ or new commentator ... but, as you know, times move on. In high-end broadcast environments these days, the (very expensive) must-have technology is the “virtual set.” News anchors address us from lavish sets, with busy backgrounds composed of gorgeous architecture and moving video displays, along with beautiful desks and furnishings in the foreground -- all computer-generated!



Selected TriCaster models bring virtual set technology to the masses with **LiveSet**. This astounding feature provides not just a background, nor even just a foreground – but along with both of those, it adds supplemental moving video displays, realistic reflections and shadows, and to top it off, supports multiple shots. You can cut between angles, and even fade or perform 3D transitions between shots.

More than this, you can just as easily live switch segments played from TriCaster’s DDRs, switching between live talent and pre-recorded segments, all in the same virtual environment. Alternatively, assign DDR (or Picture module) output to over-the-shoulder displays, or show it on ‘virtual screens’ in your ‘virtual set!’

Did we mention this was all done, not ‘in post’, but *live*?? And it all begins with LiveMatte...

8.1 LIVEMATTE

Really, **LiveMatte** is the only part of this that requires much of you, the TriCaster user; and even this bit is quite simple. Please refer back to Sections 3.2.8 in the Quick Start Guide, and 4.7 of the Input Setup heading for guidance on using the LiveMatte controls.

This latest technology is by far the best quality keyer NewTek has ever offered. Even so, when using LiveMatte, it’s crucial to start with good planning and physical preparation.

8.1.1 PRACTICAL STAGING FOR LIVEMATTE

We'd like to offer a few suggestions here to guide you in preparing, so you get the most out of LiveMatte and LiveSet.

8.1.1.1 Lighting

The single most important aspect of 'pulling a clean key' is lighting. The lighting should be even and diffuse. Hotspots and shadows create different green or blue shades on the wall, and overexposed areas lack sufficient color for clean keying. (It is not how *much* light you have on the key wall, but how *evenly lit* that wall is!) Naturally, you want to keep your green (or blue) screen clean and free of wrinkles, ripples, folds, tears, or other blemishes, as well.

Second, the distance from your talent to the screen behind can make a profound difference in key quality.

When the subject stands too close to the key colored background, the key color reflects back onto the subject, creating an 'edge' that is difficult to remove. If you have available space, move your subject farther away from the wall.

When good distance is out of the question, you can improve things somewhat by placing lights above and behind the talent, lighting them from behind with a complimentary color filter over the light to 'cancel out' unwanted reflection (for green use amber filters; for blue, orange. Don't overdo back (or top) lighting, however. The limited dynamic range of the camera means there will be little useful color data in badly over-exposed highlights. This can make it next to impossible to separate fringe zones (such as hair detail) from the background (especially when this is also overexposed!)

8.1.1.2 Analog Connections

As mentioned above, washed-out areas in the video signal lack sufficient color information to provide good separation. For similar reasons, it's worth considering the color characteristics different types of video signals.

In the analog video realm, you will encounter three main types of camera feed. We present them here in ascending order of the quality of video signal they provide (and as things go, in the reverse order of their cost, and the likelihood that you will have access to them):

Composite – a two conductor design using the classic RCA connector (also referred to as a phono connector or CINCH/AV connector)

Y/C – typically using a round, 4-pin mini-DIN connector or two BNC connectors, Y/C keeps Y (luminance) and C (chrominance) signals separate.

Hint: Y/C is occasionally called “component” (which while technically correct, can be a bit confusing given the name of the next class), S-Video (legitimate) or “S-VHS” (completely incorrect, though a common error.)

Component (a.k.a. ‘YUV’) – a three wire system typically using BNC (push & twist-on) connectors. This format uses a little math to cleverly juggle the RGB values computers favor into something less ‘bulky,’ in the interest of making best use of precious analog signal bandwidth.

Cameras and connection from either of the last two is to be preferred, but it is entirely possible to succeed with only a composite signal. When you have better available, however, use it! (Try to avoid downgrading the pre-LiveMatte signal from a Y/C camera, for example, by connecting it to your TriCaster using composite cabling.)

Hint: MiniDV cameras are not available in the Input Setup panel as live switching sources, for several reasons. However they may often be connected by Y/C cable, and in this configuration may actually provide a better color rendition for keying purpose than if they were connected by IEEE1394 cable.

This may well be true even for capturing footage for the purpose of chromakeying later in Edit Media. HDV, on the other hand, has vastly superior resolution. This largely overcomes the problems DV’s reduced color sampling can cause. Note that TriCaster edit projects can employ HD material, but actual project resolution is always Standard Definition in TriCaster.

8.1.1.3 CALIBRATION AND MONITORING

Obviously, it is more than a pun to state that good color rendition is *key* for LiveMatte. TriCaster provides convenient signal calibration tools in the **Input Setup** panel. Feed color bars from your camera(s) to the assigned Input(s), and calibrate them before beginning.

As well, a (properly calibrated) commercial quality broadcast monitor can be a big help when judging lighting and the effect of **Proc Amp** control settings.

8.2 LIVESSET

(If your TriCaster features LiveSet, continue reading here for specific details and tips.)

- Connect a camera, arrange your greenscreen, lighting and talent as just discussed.
- Use the **LiveMatte** section to set up a clean preliminary key, and you're ready to try your hand at gorgeous realtime LiveSet effects.



The PRO, STUDIO and BROADCAST TriCaster systems all feature LiveSet.

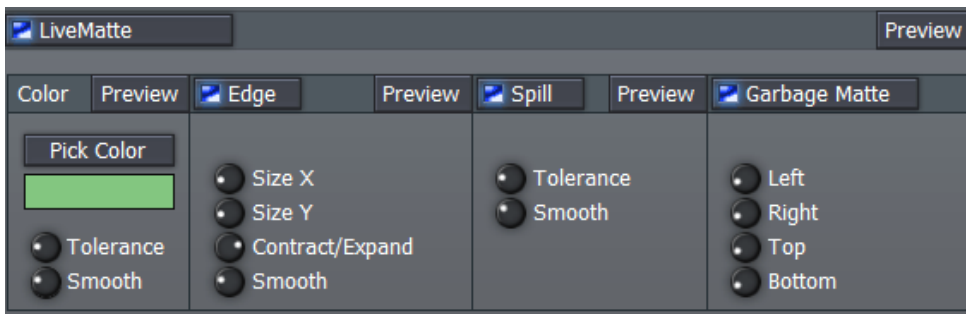
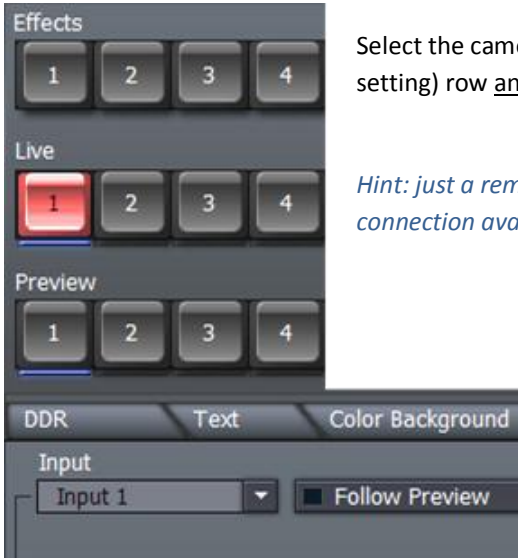

Figure 214

8.2.1 EASY AS 1-2-3

LiveSet is as easy as 1-2-3. Don't believe me? It's true -- follow along and see for yourself:



Select the camera on the Switcher's **Live** (or **Preview**, if working in a live setting) row and the **Input Setup** panel's **Source** menu.

Hint: just a reminder -- for ideal results use the best source and connection available for this part.

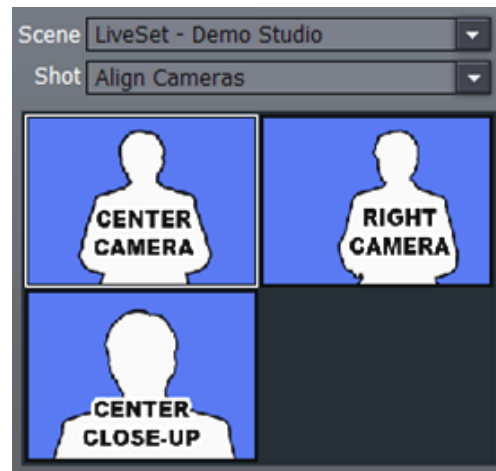

Figure 215

Choose a **LiveSet** in **Effects**, **Align Cameras** for the **Shot**, click any quadrant below, and direct your talent into position (using the white profile overlaid on the appropriate Output monitor - LIVE or PREVIEW - as guide.)

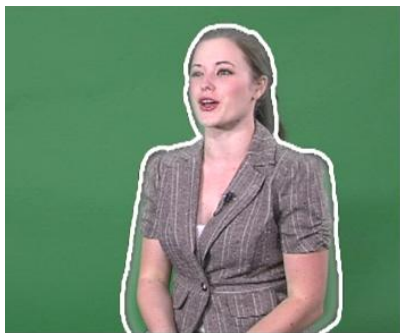

Figure 217

Figure 216



Figure 218

Check out the reflections on the desk and floor, and shadows behind. Amazing, isn't it?

Select a camera angle from the **Shot** menu, and voila! Is that cool or what?



Figure 219

Notice that in our result, a second (full motion) video source is displayed on the virtual LCD panel at left, above our virtual anchor desk. This secondary source is drawn from the **Effects Row** of the **Switcher**. You can use live video from a camera, or TriCaster's DDR (or Picture) module.

8.2.2 MULTI-CAM LIVESET

No doubt you'll think of countless applications where **LiveSet** can make you shine like the pro you are. Now that you're making money 'hand over fist' with TriCaster and LiveSet, you'll be able to equip yourself with decent equipment, including more (and better?) cameras.

Hook up your cameras, and use **LiveSet** and the **Input Setup** panel to configure the different camera angles and distances. Switch back and forth using the standard Switcher conventions, for flawless straight cuts or elaborate #D transitions.

Hint: don't forget to calibrate each camera, as mentioned earlier, so there is no change in color as you switch views!



Figure 220

Remember too, that all of TriCaster's other features remain at your service. For example, in Figure 220, we see our anchor desk with the addition of one of TriCaster's great-looking text templates masking the whole thing courtesy of the Overlay panel.

It's almost too much. 😊

8.2.3 CREATING YOUR OWN LIVESETS

Your system ships with a number of sample **LiveSets**, quite possibly some you will be able to use immediately for your own purposes. Many, however, will surely want to take full creative advantage of this powerful and versatile feature.

LiveSet technology permits a dizzying array of possibilities and applications. A series of custom LiveSet creation applications and plug-ins ranging in power and accessibility from 'easy as pie' to 'don't try this at home, kiddies!' have been and released. (Updates and additions are announced and made available via

the NewTek website, especially through your personal Product Downloads page there. Relevant documentation accompanies each tool.)

In some cases, LiveSet creation can be almost as simple as choosing two images – one for the foreground, and another for the background. More advanced LiveSet features require some knowledge of the creative tools involved (such as NewTek’s renowned Lightwave3D.)

There is one other type of LiveSet to mention in this context, though.

8.2.3.1 LIVESSET FOR TITLES AND CG

LiveSet effects don’t really *have* to be virtual sets, as we have seen. Another useful application is a simple title/CG overlay in LiveSet’s foreground channel, with your live video appearing behind it

This could serve as a secondary ‘upstream’ overlay channel (ahead of the main ‘downstream’ Overlay on the final program stream.) It could be used, for example, to apply an ever-present station identifier graphic (“bug”) - leaving your Overlay module free for more other live titling needs.

As mentioned earlier when discussing the Edit Text features in LIVE Production, you can easily create one or more LiveSet CG overlays to fill this need (Section 7.2.2.1, Export Options) with the click of a button.

9 ADMINISTRATION

Your TriCaster system is a remarkably sturdy and reliable device. There are a few things you can do to ensure it always operates at peak performance.

9.1 THE ADMINISTRATION PANEL

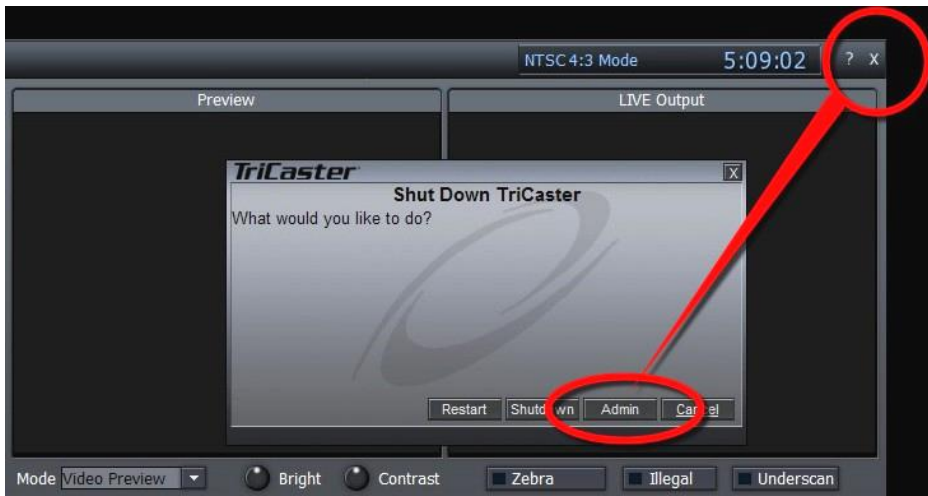

Figure 221

When you click the small [x] button in the upper-right corner of the screen, the **Shut Down** dialog appears, providing several options:

- **Restart** will exit and re-launch the system, after closing all modules.
- **Shutdown** powers the system off.
- **Admin** closes the TriCaster interface, and takes you to the Windows desktop. A special Administration Panel displayed here provides access to a number of useful maintenance functions.



Figure 222 - TriCaster STUDIO

9.1.1 RESET CONFIGURATIONS



Figure 223

Many aspects of your TriCaster interface –the playlist contents in the DDR, LiveSet assignments in Input Setup, CG projects in Edit Text, etc. – are saved from one session to the next in the Configuration file.

However, an inadvertent error condition arising during a session may cause problems when you attempt to launch the TriCaster. By clicking the Reset Configuration button, you restore the factory default settings for all modules. This is generally sufficient to restore normal functionality.

Note: files that you have saved from various TriCaster modules (such as saved Edit Media projects, exported Playlists and the like) are not affected, and can be manually reloaded after a Reset Configurations operation.

9.1.2 DEFRAGMENT HARD-DRIVE



Figure 224

It is the nature of hard drive storage for performance to gradually deteriorate over extended periods of time, particularly with frequent saving and deletion of large files (such as captured video files.) In time, it is possible for some stuttering to occur when you play stored video files. Defragmenting the hard drive re-arranges the files on the hard drive to restore optimal playback.

9.1.3 CHECK FOR ADD-ONS



Figure 225

Takes you (when connected) to the NewTek website to see what additional items related to your TriCaster may have become available.

9.1.4 SOFTWARE UPDATE



Figure 226

NewTek periodically provides new versions of the software. Clicking Check For Software Updates will check to see if you have the most recent release installed (an Internet connection is required.)

9.1.5 TECHNICAL SUPPORT



Figure 227

NewTek's legendary Tech Support is only a click away if you have questions or concerns (internet connection required.)

9.1.6 LAUNCH TRICASTER



Click here to re-launch your TriCaster software after visiting the Admin Desktop

9.1.7 CONFIGURE TRICASTER

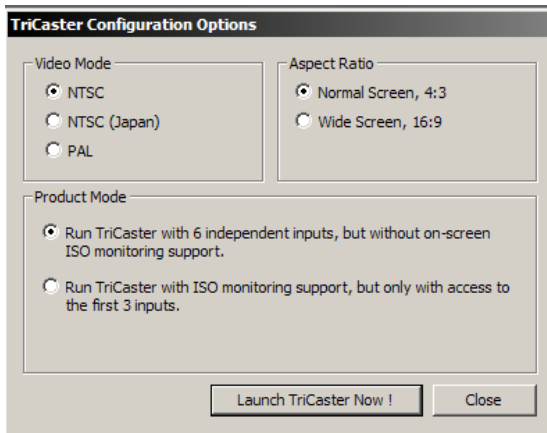

Figure 228

Click this to open the **TriCaster Configuration Options** dialog shown in Figure 229.

Note: The exact content of this panel varies from model to model.

Your selections here determine the configuration your TriCaster adopts the next time you launch it (using the nearby **Relaunch TriCaster** link on the Administration desktop.)



The upper section of the panel allows you to choose between 4:3 and 16:9 image aspect ratios (selected models may offer two video standard options, NTSC or PAL.) Just beneath this you will see the Mode section (selected models only).



Figure 229 – TriCaster STUDIO version

Note: See Section 4.12, Configure Panel (BROADCAST) for details on additional special controls featured on that model.

9.2 SYSTEM RESTORE

We firmly expect you will never need it, but isn't it good to know that a complete System Restore function is available in the event of a failure you cannot resolve?

When you first power up your TriCaster system, it automatically performs various diagnostic tests, then launches Windows™ and your TriCaster software. To access the System Restore feature, press F8 (you may need to do so a few times in quick succession, say once per second) immediately after powering up and before Windows launches. This will present you with a black screen with menu items including "Safe Mode" and "Return to OS choices menu." Choose the latter option, and then select "Restore" from the next screen.

Choosing this option will completely restore your system drive ("C") to 'as-shipped' content. This goes well beyond what **Reset Configurations**, mentioned above, is capable of. Note that any additional content you may have added after your system was new, including any TriCaster updates, will be over

written – so use this function only if you truly find it necessary (a call to NewTek’s excellent Tech Support first may often be fruitful.)

9.2.1 LIMITING USER ACCESS

In facilities where there are numerous users, Administrators can disable access to all of these utilities by renaming two files. Once accomplished, the Admin button is replaced upon exit with Logoff, which will return users to the Logon screen. The file in question is:

`C:\TriCaster\Skins\BlackBoxDesktop\Default\Normal\Initialization.ToasterScript`

Rename this file (i.e., adding an .OLD to the end of the filename). Now, in the same folder, remove the ‘SAFE’ on the file SAFEInitialization.ToasterScript. By doing this, you have prevented unauthorized users from seeing anything except the TriCaster interface. (While TriCaster is running, Windows hotkeys for Explorer, minimize, etc are disabled.) Administrators may exit to the Desktop at any time by pressing Ctrl+Alt+e

9.2.2 TRICASTER FILE EXTENSIONS

TriCaster is capable of reading many common graphic and file formats. TriCaster also creates and manipulates several different file types, for internal databases:

- .vto — TriCaster Overlay Playlist
- .vtv — TriCaster DDR Playlist
- .vtp — TriCaster Video Project

9.2.3 DEFAULT FOLDERS

While you can create your own folders on the D: partition, TriCaster stores files in the following structure:

FOLDER PATH

Effects

- `C:\TriCaster\Effects`

- C:\TriCaster\Effects\Transitions
- C:\TriCaster\Effects\Filters
- C:\TriCaster\Effects\Solid Colors
- C:\TriCaster\Effects\Titles
- C:\TriCaster\Effects\Titles\Templates

Clips

- D:\Media\Clips

Projects

- D:\Media>Edit Projects

Pictures

- D:\Media\Pictures

Playlists

- D:\Media\Playlists

Streams

- D:\Media\Streams

10 STREAMING, NETWORKING AND THE INTERNET

Live webcasting has dramatically altered the broadcast landscape. Information can now be shared among audiences around the world for a very small transmission cost – and the future is bright!

10.1 STREAMING STRATEGIES

One of the best approaches when beginning (to stream your productions) is to establish a relationship with a commercial streaming media provider. A good provider can guide you past firewalls, provide public addresses for everyone to view your stream, and provide no end of valuable guidance. And, it may not be as expensive as you think (costs vary based on considerations such as how many people watch your stream, how much web bandwidth you use each month, and so-on.) Some services based on an advertising model will even host your stream free!

10.1.1 ON DEMAND, OR LIVE?

Not all ‘streaming’ is ‘live streaming.’ The difference is similar to a) watching a television program you previously recorded at a time convenient for you, or b) watching a live event.

On demand streams are stored on a server (often supplied by an external service provider), ready to be transmitted whenever a viewer wishes. Live streams are only available at the time they are broadcast, such as during a live concert or event.

10.1.1.1 ON DEMAND HOSTING

TriCaster permits you to record live productions to a local hard drive. The resulting files can be hosted on a network later, so viewers can connect whenever they like. If you have the resources available, you can host the video yourself – but if many people will likely want to view your production, you will likely avail yourself of a service to stream it on your behalf.

Ideally, ‘on demand’ streaming video begins to play on request after a few moments of buffering - to let the stream get a bit ahead of the client playback device. (This stands in contrast to other types of online video distribution which requires the viewer to completely download the video file before he can begin play.)

Given a sufficiently high speed connection between host and viewer for particular streaming video, they may well be able to enjoy a seamless viewing experience without stuttering or other issues.

10.1.1.2 LIVE STREAMING

Live streaming is a growing international market, and one you may well wish to serve. This form of streaming is a somewhat more demanding implementation. Rather than record a file and deal with it later, live video is transmitted over the network (effectively in realtime, give or take a little ‘time in the pipe’ as it were.) Delivering a good quality stream requires that you consider both your network connection capabilities and that of your viewers. As well, to ensure reliable deliver, you will ideally have some idea of the size of your audience. Nevertheless, for all cases, TriCaster gives you the tools to do the job!

Naturally, streaming video is highly compressed to reduce bandwidth demands and make it available to a wider group. TriCaster supports two popular and prolific encoding systems, Microsoft’s Windows Media™ and Adobe Flash Media®.

The decision as to which encoding format to use for your live stream is up to you, or in some cases – your client. Here are some things to consider:

- Some corporate and institutional network administrators opt to support one or another type exclusively. (Check with your IT department to find out if this affects your decision.)
- Flash has a very wide installed user base, and seems poised to increase in proliferation in the foreseeable future.
- Flash works well across PCs, Macs, Linux, etc. Windows Media is well represented, but perhaps not quite to the same degree.
- Some sources report that the Flash movies will have a larger file size and use greater bandwidth than Windows Media for a given stream quality. (This is hard to assess, and changes constantly.)
- Codecs for both types are updated with fair regularity, and when you choose the ‘latest, greatest’ encoding, your viewers may not all have the current player, requiring them to download and install updates.

10.1.1.3 BANDWIDTH CONSIDERATIONS

You’re going to hear and use the term ‘bitrate’ in connection with streaming video. This expression refers data throughput per second (generally measured in Kilobits per second, or Kbps.) Think of it as being like water flowing through a hose. You control the ‘faucet’, because you get to choose the Streaming Profile

in your TriCaster’s Stream to Internet panel. However, you don’t own the ‘hose’ – or at least, not the entire hose. Once the stream leaves your immediate environment, even if you can supply good throughput locally, bandwidth may be constricted elsewhere along the transmission path.

Internet traffic can impose some limits, but a major concern is the sort of connection your viewing audience may have. Consider an example:

Even though you know that most of your audience are going to connect to your program using (relatively slow) wireless devices, you use a very high outgoing bitrate – thinking that this will surely be enough to fill the need. The fact is though, your high bitrate actually ensures their experience will be poor!

The client player tries to play the stream at the bitrate you specified, but (in this example) the wireless bottleneck impedes flow. It is as if you connected a fire hose on your end, giving them a suitable high capacity nozzle for their end – but in the last stage of flow, the stream must pass through a small garden hose. Sadly, the stream will be quite insufficient, and output from the ‘nozzle’ (the client player) will falter badly.

For reliable performance, try to ensure the potential upload bandwidth from your system to the net is around twice the bitrate you choose. You *can* broadcast at a rate closer to your actual ceiling, but reliable performance cherishes headroom.

Also consider the expected download abilities of your viewers. Ideally, a safety margin 1.5 times the stream’s bitrate is desirable. This may mean you need to consider using a lower resolution, or lower framerate for your stream – but doing so when required will generally deliver a smooth result, and is the wise course. Nothing inclines viewers to turn away quicker than a stuttering, start and stop stream. See 10.4.1.4, Speed Tests for some useful resources.

10.1.2 STREAMING PROTOCOLS

Additionally, there are two primary streaming methods, known as “Pull” and “Push.” Choosing the best method for your needs is important. Let’s review each, and consider what is best for your needs.

10.1.2.1 PULL BY END USERS

Simply put, the Windows Media Encoder on your TriCaster allows your (networked) audience to connect directly to it, and it distributes the stream to them.

Connecting in this manner requires you to have a connection with sufficient bandwidth to deliver a stream to each individual user. For this reason, the simple Pull streaming method rarely works well for more than 1 or 2 viewers.

Advantages:

- If your TriCaster is not behind a firewall or does not have a public IP address, this is a very simple way to let a few viewers watch your program stream.

Disadvantages:

- Requires either a public IP address or requires users to be on the same network. Facilities such as hotels or convention centers will usually not provide a public IP address. Even if they do, getting them to open holes in their firewall is next to impossible
- If your TriCaster is behind a router, your router must be configured to 'port forward.'
- Requires significant bandwidth -- for example, for a TriCaster connected to the Internet by a DSL or Cable Modem line, upload bandwidth is often less than 400kbits/second. Allowance for network overhead, at best a 320kbit steam can be accommodated. This bandwidth would be fully consumed by two viewers watching 160kbit streams, or a single viewer pulling a 170-320kbit stream. (Even a T1 digital line can only handle four simultaneous 300kbit streams.)

A variation on the Pull method involves using an external streaming provider. At one time the *only* method for streaming using such a provider was to have the server 'pull' it from the encoder.

Under this system the server did not receive the stream until the first user requested it. Then the server would connect to the encoder, pull the stream to it, and finally begin re-distributing it to everyone requesting it. This method worked passably until firewalls became more common.

Advantages:

- Pull doesn't waste bandwidth; no signal is being sent out to the server unless somebody wants to view it.
- If you lose your connection to the (provider side) server, the server will re-connect to your encoder automatically when Internet connection resumes.
- Providers typically have significant bandwidth, and are able to meet necessary requirements to deliver stutter-free, high quality streams to large numbers of viewers.

Disadvantages:

- Like the “Pull by End Users” method above, this requires a public IP address, preferably a “static IP address” (which does not change dynamically if you need to reconnect) as well as open ports for the connection to be established. These requirements are becoming increasingly difficult to meet (given common security measures.)

10.1.2.2 PUSH TO PROVIDER

Windows 2003 Server introduced “Push” technology. With this method, the encoder sends the stream to the servers. This allows the encoder to establish a connection to the server on a specified port. Once this connection is established, additional network ports may be opened as required (since the Encoder established the connection, not the server.)

Advantages:

- Easy to connect to the provider. There are no requirements for open ports on your local system, or public IP’s. In addition, firewalls do not get in the way.

Disadvantages:

- Live streams that have no viewers are still consuming bandwidth. From a provider point of view, it is possible that all of our bandwidth could be utilized with no viewers. However, that is more theoretical than practical.
- Some external streaming providers *prefer* to Pull streams, as re-connection can be performed from their end automatically if necessary. But in many venues system administrators are very reluctant to configure their system with an open port to have your stream Pulled from.

10.1.3 STREAMING MEDIA PROVIDERS

Using a commercial streaming media provider (sometimes referred to as a Content Delivery Network or simply CDN) bypasses otherwise high-bandwidth requirements for the encoding computer. When you have made arrangements for a streaming media provider to distribute your stream, the encoder only needs enough bandwidth to get a single a/v stream to the provider. All end users connect to the provider to view the stream.

Most streaming providers have access to massive bandwidth (and often, with a few hours notice, they can scale up your allotment on demand to meet a special need.) Since your local bandwidth is really only used for uploading a single stream, you can send a high quality stream, secure in the knowledge that it will not degrade as soon as a second viewer attempts to see it.

HINT: If you need to find a good streaming service provider, ask TriCaster customers for recommendations in the NewTek discussion forums.

10.1.4 OTHER RESOURCES

If you're still struggling with the differences between Push and Pull streaming methods, you can find lots of online resources (in addition to excellent information available in NewTek's user forums!)

The popular web resource Wikipedia® hosts many articles on the subject, notably these two:

http://en.wikipedia.org/wiki/Push_technology

http://en.wikipedia.org/wiki/Pull_technology

Microsoft even hosts an animation on the subject at:

http://www.microsoft.com/windows/windowsmedia/knowledgecenter/wminaction/streaming_pushpull.aspx

(Ignore the detailed discussion of configuring the encoder, and just enjoy the pretty pictures - TriCaster makes that part easy for you!)

10.2 TRICASTER STREAMING



Figure 230

Sending your video program output across a network (whether a local *intranet* or the Internet) can be almost as easy as connecting TriCaster to the network and pressing the Stream Output button on the lower left corner of the Live Production tabbed panel.

All the settings you need to configure your streaming output are located in the panel displayed when you click the Record/Stream tab (near the center of the LIVE Production tabbed screen.)

As mentioned above, TriCaster offers two encoding methods -- Adobe Flash® and Microsoft Windows Media™), along with two streaming modes Push and Pull. (We discussed these earlier in this chapter, and you've likely decide which is best for your purposes.)

10.2.1 PULL PROFILES

If you are streaming internally (to people in your building or inside your own corporate firewall), Pull streaming may provide the easiest approach. (Be aware that since your stream may be constrained by lower bandwidth than a commercial streaming service typically offers, Pull streaming may falter when more than a few users are viewing the stream.)



Figure 231

To see what Internet address to provide your customers or streaming provider, select a suitable Pull profile from the **Stream Type** menu. After pressing the **Stream Output** button, the stream will commence, and the button will turn red to indicate this.

Note: Flash streaming does not support Pull type connections. The Windows Media Encoder on your TriCaster supports Windows Media 11 and VC1 presets. VC1 is the video standard for HD DVD and Blu-Ray™ players, and is also used in some other environments such as gaming applications.

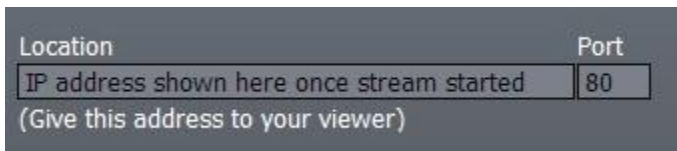

Figure 232

Once you begin (Pull) streaming, TriCaster displays the system's IP (Internet Protocol) address of your computer on the network. This information will be provided as 'punctuated' numeric value in the **Location** display field.

You can then drag the mouse over this address to highlight it, press Ctrl-c to copy it and send this address* to your customers or streaming provider. Your TriCaster program stream will go continuously to the network while Stream Output is enabled.

**IMPORTANT NOTE: If your TriCaster is connected to the network by a router, the IP number shown in the location field is only valid for viewers connected on the same side of the router as your TriCaster (as they might be in a local intranet configuration.)*

Routers provide a measure of network security by masking the details of systems connected to them, thus preventing direct external access. The Location shown by TriCaster in this case is merely a local number assigned by the router, not accessible to the world at large. To find out how to provide external access to your stream in this configuration, please see Section 10.4, Configuration and Troubleshooting for information on Routers and Port Forwarding.

You can provide any clients or streaming providers this mms: (Microsoft Media Server) address. Entering this address into the File menu of Windows Media Player (using copy, and pasting it into the Open URL window) will direct the player to show the stream from your system on client computer system(s) connected to the Internet.

Hint: Most web browsers can be also configured to invoke a compatible player when required, as well, but using WMP directly in this fashion may save some steps.

10.2.1.1 WRITE TO DISK

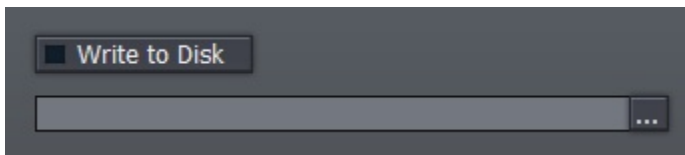

Figure 233

The **Write to Disk** option allows you to archive the live stream as a .wmv file (Windows Media Video.) Click the ellipsis (the [...] button) beforehand to choose where you wish TriCaster to save the resulting file.

*NOTE: If the **Write to Disk** option is chosen, it's important to remember to turn off the **Stream Output** button when the presentation concludes, or TriCaster will continue writing this file.*

10.2.2 PUSH PROFILES

Push streaming is generally the most convenient method, especially in cases where your TriCaster is connected behind a Firewall and can be easily arranged with your streaming provider.

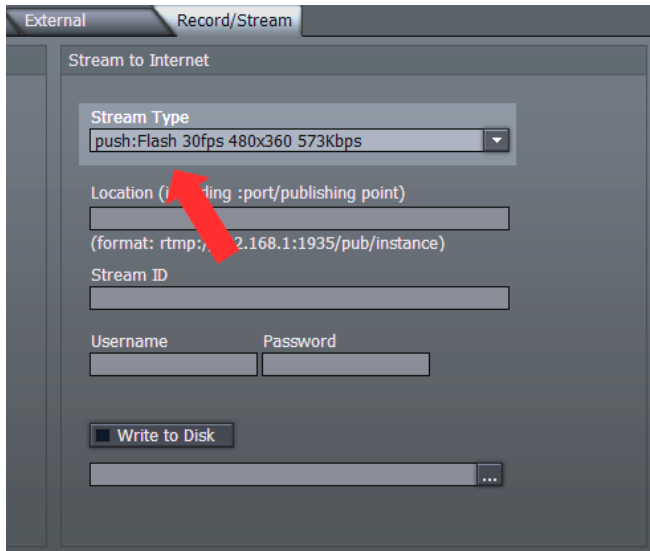

Figure 234

As discussed earlier, Push streaming is usually simpler when you need to stream from major venues (such as hotels or convention centers.) The program stream passes quietly out through any firewalls or routers between the facility and your streaming server.

Also, once your streaming provider has provided you the connection specifics, you can resume the stream at any time without intervention from the server.

When a push profile is chosen, the Streaming interface changes to allow entry of web address, user and password.

NOTE: the publishing point is placed at the end of the URL after a forward slash (i.e., <http://225.21.1.4:8080/NewTek>).

Selecting a Push profile from the drop-down **Stream Type** list and enabling the **Stream Output** button at lower left “pushes” the stream out of your location, and logs in to a pre-arranged web address with username and password. (You enter these details in the fields provided in TriCaster’s **Stream to Internet** pane beforehand, of course.)

10.2.2.1 WRITE TO DISK

Again, the **Write to Disk** option allows you to archive the live stream as either a .wmv file (Windows Media Video) or an .flv file type (Flash Media Video) - according to the encoding format appropriate for the Push profile you select.

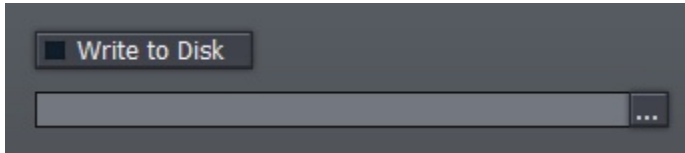

Figure 235

Click the ellipsis (the [...] button) beforehand to choose where you wish TriCaster to save the resulting file.

*NOTE: If the **Write to Disk** option is chosen, it's important to remember to turn off the **Stream Output** button when the presentation concludes, or TriCaster will continue writing this file.*

10.3 PRODUCTION AND CAPTURE CONSIDERATIONS

If you're not intent on live streaming, but wish to capture a live switching session, you would be likely record at full resolution using the **Record Output** button(rather than using the **Write to Disk** function in TriCaster's **Stream to Internet** area.)

The high quality captured files can then be used later in TriCaster's DDR's, edited in Edit Media, or even be transferred to another computer (even on a different platform) for external processing or editing.

Hint: use an external hard drive to transfer the files, or simply transfer them over a network.

You can always convert these files to a streaming file format later if you wish to supply them for on demand viewing over the Internet. This lets you retain best quality right through to final output. When you eventually encode it for streaming, you can choose streaming settings that best suit the intended audience and streaming environment.

At the very least, if (perhaps to save conversion time) you capture video for Web distribution, it's best to capture it at (at least) the size that you intend for final output, to ensure satisfactory video quality for your viewers. When video is compressed (as it must be for the Web) you can lose important detail; compressing a full-screen video down to a quarter or a sixteenth of its size is a lesson in humility!

OTHER FACTORS

Other variables to keep in mind when you're creating video for the Web are contrast and motion. During video encoding for Web distribution, a fair amount of video information and detail can be lost. For this reason, good lighting of your source video is essential.

Also, web streaming doesn't handle detail, transitions and motion all that well -- so your best shots should be close up, and without a lot of movement.

Too, audio from cameras and camcorders is rarely as good as separate microphones. You should at least use a clip-on lavalier microphone, directional or shotgun microphone to be sure you record only the audio you really want.

10.4 CONFIGURATION AND TROUBLESHOOTING

As technologies go, video streaming is still in adolescent phase, at best. There are a lot of different standards and diverse environments to consider. TriCaster gives you the necessary tools, but there are still some teething problems you may encounter. This section will point you in the right direction to overcome them.

10.4.1 TESTING YOUR STREAM

When it comes to using your TriCaster in a professional live production environment (i.e., your bread and butter depends on getting it right, and now - not tomorrow), failure to test beforehand is not merely unwise - it can be professional suicide.

You should already be aware of the need for redundancy in a professional environment (you didn't bring just one camera, did you?) As reliable as any device may be, Murphy and his Law are alive and well. So you plan for this, bringing the appropriate equipment, such as uninterruptable power supplies, backup recording devices (there's no shame in having a VCR backing up your digital record -- 'low tech' still has a place in the grand scheme.)

But you also need to perform onsite testing, to ensure your live stream is working well before 'zero hour.' No-one will thank you for excuses, no matter how brilliantly they point the finger at forces beyond your control.

- Set up and enable a test program stream from your TriCaster.

- Use another system to open Windows Media Player™, and use its menu (in some versions, you need to right-click WMP's title bar to present the menu) to select **File> Open URL**.
- Enter the IP address and port number for your stream here
- You should be able to connect and view your program stream

Success at this point does not necessarily mean you're done. You may be able to see the stream locally, but can someone outside the local environment connect to it over the Internet?

The best way to find out is to have someone at a remote location verify that your stream is streaming properly. If it is, great! Otherwise, keep reading...

10.4.1.1 TESTING WITH PING

Before your stream can be seen - whether on a local intranet or the Internet - client computers (or your service provider) need to be able to establish a network connection with your TriCaster. **Ping** is a humble but effective tool to ensure the basic connection exists, thus It can help you with streaming, **iVGA** and **LiveText** connection issues, too (and it works just fine in a multi-platform environment!)

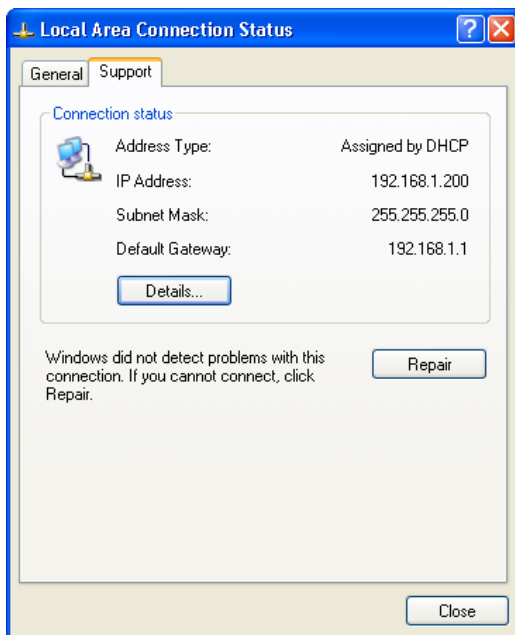

Figure 236

Ping sends a small set of data packets to the target host (IP number), then 'listens' for an echo response in return. Ping estimates the round-trip time in milliseconds, records any data losses, and displays a summary when finished. Bottom line, if you can't ping your target, your connection has problems (the problem might be as simple as a bad cable connection.)

Finding the target IP number:

To issue a ping, you need know the IP number of the target computer.

On a Windows XP® system, you can find this number by:

(On TriCaster, click the [x] button in the upper-right corner of the screen, and select **Admin** to get to the Windows Desktop.)

Next, select **Network Connections** from the Windows **Start Menu** (look in the **Settings** sub-menu if it is not

listed at the top level.)

In the **Network Connections** panel, right-click on the icon for your **LAN** (local Area Network) and select **Status**. The **IP Address** for the system is shown on the **Support** tab.

To find the IP Address for a system running OS X®:

Click the Apple icon at upper left on the Desktop, and select About **This Mac**. Click **More info ...** in the panel which opens, then click **Network** in the **Contents** column at left. The IP number for the Mac will be listed in the right hand pane.

Issuing a Ping

Ping is a command line program, and must be run from a command shell on the issuing computer. To open a command shell and send a ping, follow the procedure below that applies.

Windows

- On TriCaster, click the [x] button in the upper-right corner of the screen, and select **Admin** to get to the Windows Desktop.
- For all Windows XP® systems (including TriCaster) select the Windows Start Menu command **Run**
- Type “**CMD**” (without quotation marks) into the **Run** dialog panel
- Press your **Enter** key a command shell window will open.)
- Type “Ping” (without quotes) followed by a space and the target IP number, as in the image below – then press **Enter**.

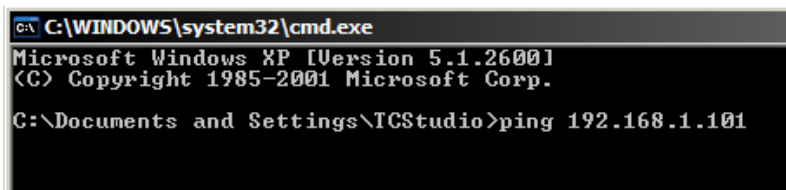

```
C:\WINDOWS\system32\cmd.exe
Microsoft Windows XP [Version 5.1.2600]
(C) Copyright 1985-2001 Microsoft Corp.

C:\Documents and Settings\TCStudio>ping 192.168.1.101
```

Figure 237

- Ping will go to work, and in a moment or two begin reporting results. A ping *failure* (indicating a network problem) will look like Figure 238. A success ping will display a report like Figure 239.

```
C:\WINDOWS\system32\cmd.exe
Microsoft Windows XP [Version 5.1.2600]
(C) Copyright 1985-2001 Microsoft Corp.

C:\Documents and Settings\TCStudio>ping 192.168.1.101

Pinging 192.168.1.101 with 32 bytes of data:

Request timed out.
Request timed out.
Request timed out.
Request timed out.

Ping statistics for 192.168.1.101:
    Packets: Sent = 4, Received = 0, Lost = 4 (100% loss),

C:\Documents and Settings\TCStudio>
```

Figure 238

```
C:\WINDOWS\system32\cmd.exe
Microsoft Windows XP [Version 5.1.2600]
(C) Copyright 1985-2001 Microsoft Corp.

C:\Documents and Settings\TCStudio>ping 192.168.1.101

Pinging 192.168.1.201 with 32 bytes of data:

Reply from 192.168.1.201: bytes=32 time<1ms TTL=128
Reply from 192.168.1.201: bytes=32 time<1ms TTL=128
Reply from 192.168.1.201: bytes=32 time<1ms TTL=128
Reply from 192.168.1.201: bytes=32 time<1ms TTL=128

Ping statistics for 192.168.1.101:
    Packets: Sent = 4, Received = 4, Lost = 0 (0% loss),
    Approximate round trip times in milli-seconds:
        Minimum = 0ms, Maximum = 0ms, Average = 0ms

C:\Documents and Settings\TCStudio>_
```

Figure 239

Apple OS X

For a system running Apple's OS X®, double-click **Terminal** in the **Applications\Utilities** folder. Type the following command into the Terminal (without quotations) and then add the IP number, and press **Enter**:

"ping -c 4 ipnumber."

So, for example, you might type: `ping -c 4 192.168.1.101`

The response will be similar to the Windows example described above. Again, a ping failure indicates a problem with the network connection.

10.4.1.2 PULL CONNECTION ISSUES

Note that - if you are Pull streaming from ‘behind’ a router – the IP number shown in the TriCaster’s **Location** field will only be valid for other systems behind the router. You will need to derive the true external IP address to pass to your viewers (or service provider.) You will also need to enable “port forwarding” on the router.

Again, in this environment you may wish to consider Push streaming with the aid of a Content Delivery Network (a commercial service), as this is generally free of firewall and router woes that often require a friendly system administrator to resolve otherwise.

Port Forwarding

If you are streaming from behind a router, to preserve a reasonable level of security while allowing outside computers to connect to your system you will need to ‘port forward’ your router.

Port forwarding permits a sort of ‘blind hand-off’ between external clients (your viewers) and a local transaction port which you manually specify. (The router will pass requests to view the stream through to the TriCaster, without exposing the internal IP routing.)

To enable port forwarding, you need three pieces of information:

1. The login information for the router. Your router’s manual will have this information, which typically involves entering a specific IP number into your web browsers URL field, and perhaps also a password you have set previously.
2. The specific IP local number that the router has assigned to your TriCaster. You can read this right from the TriCaster’s **Location** display. It will comprise the entire string of punctuated numbers before the colon (the colon separates the port number you chose for your stream.)
3. The port number just mentioned (the part *after* the colon.)

Although the steps vary a bit by brand and model, generally you would proceed as follows:

1. Log into the router, so it shows it's control panel in your web browser

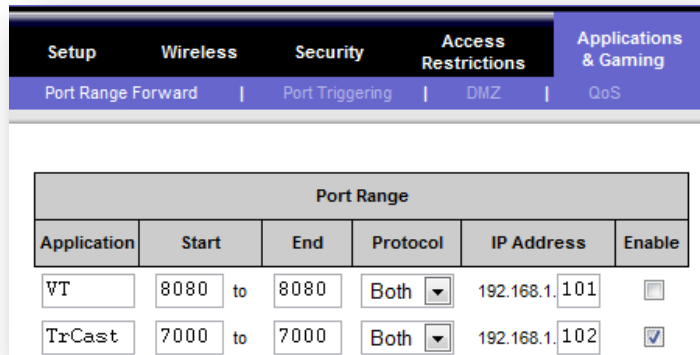

Figure 240

2. Select the port forwarding page of the router controls. These options may be found in an obscure place, such as the router's "Applications and Gaming" page (since online gaming often requires port forwarding.)
3. Enter an **Application** name, if required (this is for your own recognition purposes, so use anything you like)
4. Enter the **Start** and **End port** values – you can use the same port number in both fields, but of course it must be the one you set in the TriCaster's **Port** field.
5. IF possible, select **Both** for **Protocol** (or select UDP)
6. Enter the full (punctuated numeric) local IP address shown in the **Location** field of your TriCaster after you enable the stream.
7. Checkmark **Enable**

*Some routers may have other security settings that need to be modified for your Pull stream to be visible from the outside. For example, the Linksys® router shown above has a setting in the **Security** page named **Block Anonymous Internet Requests**. While this may be a great idea*

normally, it's not going to help much when outside computers request that your system permit them to Pull the video stream, is it?

There are countless makes and models of routers – for information on various models, and a great deal of help on port forwarding generally, we can recommend the following site”

http://www.portforward.com/english/routers/port_forwarding/routerindex.htm

Firewalls

You may also run into software firewalls. Generally, these can be configured in similar to permit exceptions to the firewall policy, permitting specific ports or applications to be opened to the world. Information on exception in the Windows XP Firewall can be found in its Help system:

- Open the Windows Security Center (double-click its icon in the Task Tray)
- Click "How does a firewall help protect my computer"
- Click "Related topics"
- Select "What are Windows Firewall settings used for?"
- Click "Related topics" again.
- Click "Allowing a program to communicate through Windows Firewall"

10.4.1.3 FINDING YOUR EXTERNAL IP NUMBER

Again, the numbers assigned behind your router only work locally. In a Pull scenario, you need to supply the true external IP number (and port) for your TriCaster to viewers outside the LAN (Local Area Network.)

You can find this number in several ways. For example, your router will display it as its "IP Address" in its Status page. Or, you may want to simply one of several handy websites that will quickly supply your current IP number (one such is <http://www.whatismyip.com>). Simply go to the website in your browser and read the IP number from the screen. Append a colon and the port number you are using to this number and you've got everything you need for your viewers to connect.

10.4.1.4 SPEED TESTS

Are you sure your upload bandwidth is adequate to the bitrate you've set for your stream? Why not test and make sure. Again, a number of websites provide free speed testing. These will give you a basic idea of what your local bandwidth really is. One site which provides a list of online speed test resources is: <http://www.dslreports.com/speedtest?more=1>

11.1.1 RESOURCE CONSIDERATIONS

In George Orwell's famous allegory *Animal Farm* a character states "All animals are equal but some animals are more equal than others." Likewise, though bearing a strong family lineage and feature set, individual TriCasters do vary. As well, even for identical TriCasters, owners and their needs and working environments diverge widely.

For example (just to consider a few matters) -- it is *possible* on all TriCaster version 2.0 models to encode and stream the video program to the Internet in realtime, to simultaneously record the compressed and encoded stream as a file to the hard drive, likewise to record the full-size program output to the same or a different hard drive. As well, that output may be concurrently sent at very high resolution to projection devices, and also to standard television displays. Further, the program itself (or some portion of it) may be playing from previously recorded files – on the same hard drive!

For a given system, all of this may be *possible*, while 'biting off too much' may overtax another. What's the point? Well, there are several notions to be drawn here:

First, be reasonable...

Perhaps you've had your TriCaster for quite some time, and it has been a real workhorse. Now, the march of technical progress has made more wonderful things possible. If your TriCaster has been updated, you may have access to many new powerful features.

Still, all else being equal older hardware may not be quite as capable in all respects as that which shipped this morning. Your system can indeed do many wonderful things – but attempting all *of them at once* may not result in expected performance. (For example, you might see frames being dropped from the program stream if the system is struggling to keep up.)

Second, even when you think doing all of the above is quite reasonable, test first. Professionals simply do not leap into new environments blindly. They prepare, plan, plan some more, and then - most importantly - they test! This allows them to tackle the really tough jobs with confidence.

11.1.2 IMAG AND LATENCY

What's IMAG? It's a compression of the expression "image magnification." Typically in modern IMAG applications, video cameras supply live imagery to projection systems, magnifying speakers and performers so that audience members further back in large venues can still see what's going on.

IMAG is a very tricky task at the best of times, one that calls for excellent planning, and where possible, testing. Those designing an IMAG installation have, not just one, but two inter-related broadcasts to consider – in the form of the audio and video streams.

11.1.2.1 RELATIVITY AND THE SPEED OF LIGHT

Wouldn't it be nice if audio and video travelled from their respective broadcast devices at the same speed? Then, wherever you were seated in the audience, the sound from hypothetically perfect speakers and the video image from huge video displays co-located at the front of the auditorium would reach your ears and your retinas at precisely the same moment!

This is not the case, however. Sound travels quite slowly – so slow, in fact, that even in relatively small venues it reaches those in the rear of the audience noticeably later than those in the front.

In loose terms, for a mid-size auditorium 600 feet long, it takes around a half-second for the audio to reach those in the back. For this reason, audio engineers often position speakers throughout the 'house', then introduce carefully considered delays by electronic means - to ensure 'late sound' from front speakers does not arrive after sound from the nearest speaker to those further back.

Light, on the other hand, travels so much faster that for all intents transmission can be considered instantaneous in the same setting. So a person in the rear will see the image on a screen at the front long before sound from a *co-located* speaker arrives.

If transmission of the video signal from the camera's lens right through to the projection screen were instantaneous all we'd have to consider (it's not, mind you!), we'd likely need to find a way to delay it. Otherwise, the carefully timed delays the audio engineers induced would ensure a mismatch between video and late arriving audio. Viewed in this light, a certain amount of latency is actually "A Good Thing!"

Still waiting for the promised mention of 'relativity'? OK, here it is then: $E=MC^2$

11.1.2.2 LATENCY AND YOUR AUDIENCE

“Latency” - what’s that you ask? In this context, latency refers to the time it takes for the video signal to transit one part of the IMAG path, from camera lens to final display. Latency is usually expressed either in milliseconds or in video “frames” (typically either 25 or 29.97 to the second.)

As we said above, really a little video latency is not a bad thing as viewed from a surprisingly short distance back into the audience. This is just as well, since for all practical purposes a little latency is also unavoidable.

Even so, as long as audio and video are in sync *at your seat*, only a rather ‘significant’ degree of latency will be objectionable – unless you happen to be very near the stage. For those in the front rows, a few extra frames of latency *may* be rather disconcerting. (It’s true that IMAG was conceived primarily for the benefit of those further back, but if the latency is too obvious for those nearest the front it can be disconcerting distraction.)

For this reason, it’s desirable to keep video latency to an agreeable minimum – but put away any notion of ‘zero latency.’ Not only would this require bending the laws of physics, it would be a bad idea.

Even before considering minimizing latency in the device chain, acknowledging that there is always going to be some latency calls for some creative thinking with regard to practical staging. For example, if you design your IMAG layout in such a fashion that those in the front row are unlikely to be able to see the screen(s) without lifting their eyes from the onstage talent, they are extremely unlikely to notice a small amount of latency.

11.1.2.3 LATENCY AND YOUR TRICASTER

TriCaster is a wonderful tool in the IMAG arsenal, but inevitably it is only one (albeit critical) link in a chain of devices. It is common for each device to contribute a little to the combined total latency for the system.

TriCaster’s portion of the total latency sum is well within standards for devices of this sort - between 2 and 3 frames. The actual amount can vary slightly within this range, depending on several factors.

For example, suppose a ‘video frame’ supplied by a camera arrives at TriCaster’s inputs one millisecond after a different frame has been sent to the output. Obviously the new arrival must wait its turn; it can’t be transmitted until the correct duration for its predecessor has elapsed. Thus the newly arrived frame must ‘wait’ almost one entire frame, until its turn comes.

How can you achieve the lowest possible latency for the TriCaster section of the IMAG chain? To do so, 'Genlock' your cameras to the TriCaster output. You can do this with any camera that has genlock capabilities, using any model of the TriCaster.

Genlocking can be performed with suitable cameras as follows: connect TriCaster's composite output as the Genlock source, feeding it back to the cameras Genlock connection. Adjust the 'genlock phase' setting at the camera to get the lowest possible latency. This allows TriCaster to bypass its input time-base correctors, diminishing latency by about one frame (to its potential of just two frames.)

Hint: you can actually assess the latency of your TriCaster installation fairly easily. Run timecode directly to 1) a monitor and at the same time 2) through the TriCaster to a second (identical) monitor. Take a photograph that encompasses both monitors, and compare the timecode shown!

11.1.2.4 OTHER SOURCES OF LATENCY

More often than not, significant latency is added by other devices in the IMAG chain that come *after* the TriCaster's. Projectors are a common contributor, but at times the cameras themselves are a factor. Here are some helpful points to consider when designing and connecting your system:

1. If you use DVI or VGA output from the TriCaster to the projector -- if at all possible, match the resolution sent from the TriCaster to the native resolution of the projector. On some projectors this allows the unit to avoid using its own internal scaling, which is often a significant factor in unwanted latency.
2. When possible, try supplying the projector with analog video. This can eliminate a lot of the complexity from the process (of course, this is not always possible.)
3. Certain projectors provide a special 'low latency mode' to disable features of the unit that carry a heavy toll in latency. Enabling this mode can make the positioning of the projector slightly more challenging (as you may sacrifice some ability to position and scale the image using projector menu functions) -- but the latency reduction can be very worthwhile.
4. Some cameras include features that add more latency than you would expect. For instance, image stabilization (by definition) add one field of latency and sometimes more. Disable anything of that sort that you can.

12 APPENDIX A — SIGNAL FLOW

There are numerous TriCaster inputs and outputs for audio, video and VGA signals. Here are simplified flow diagrams to explain this for each model:

12.1 TRICASTER

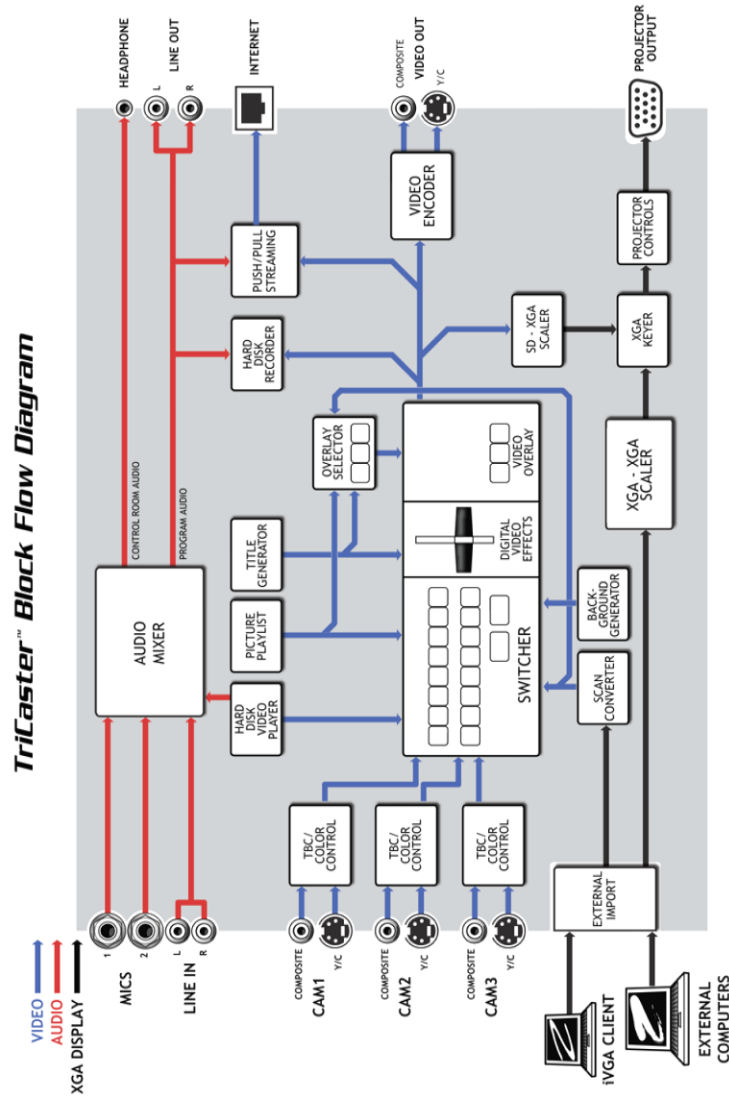

12.2 TRICASTER PRO

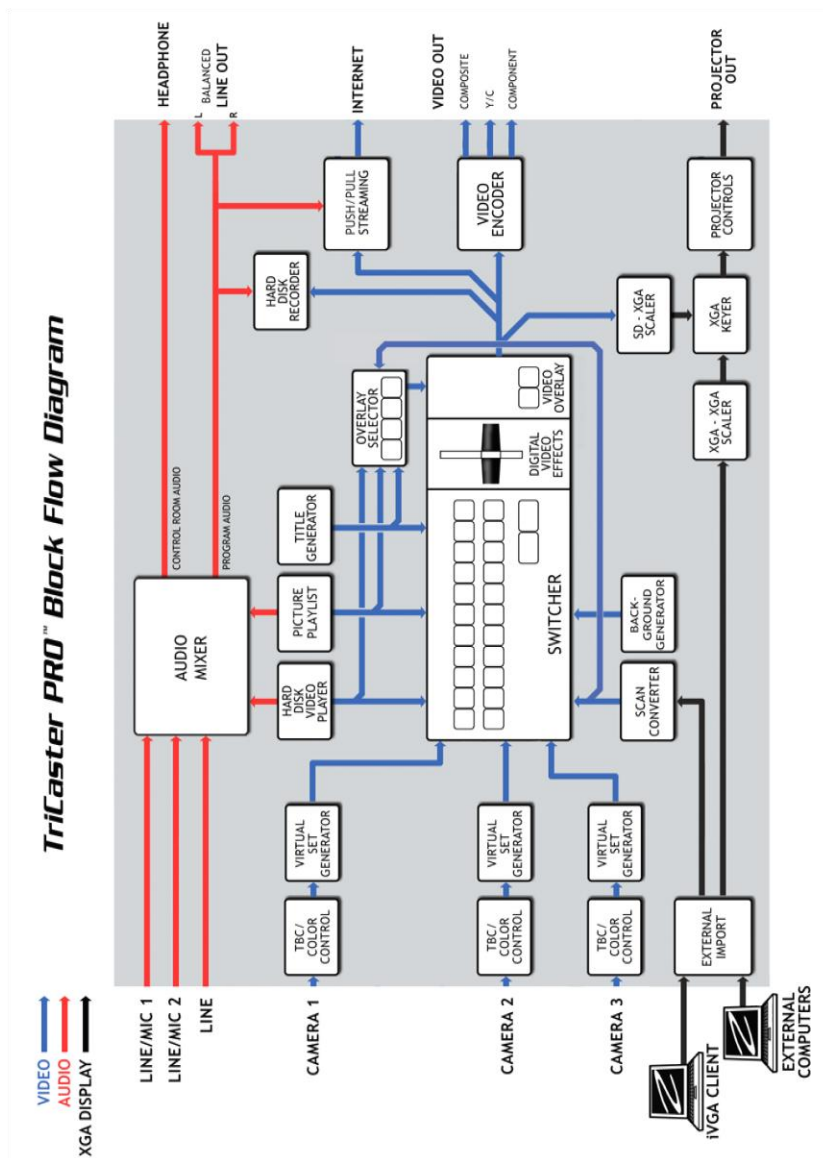

12.3 TRICASTER STUDIO

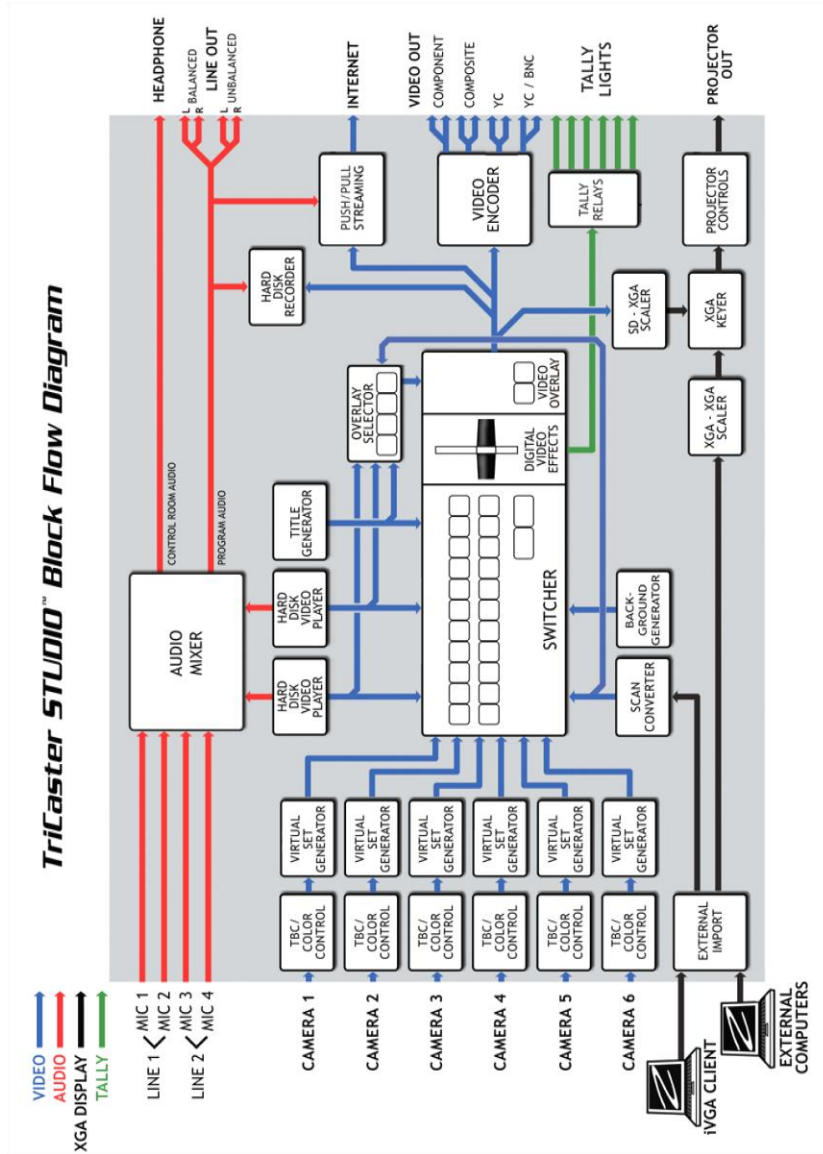

12.4 TRICASTER BROADCAST

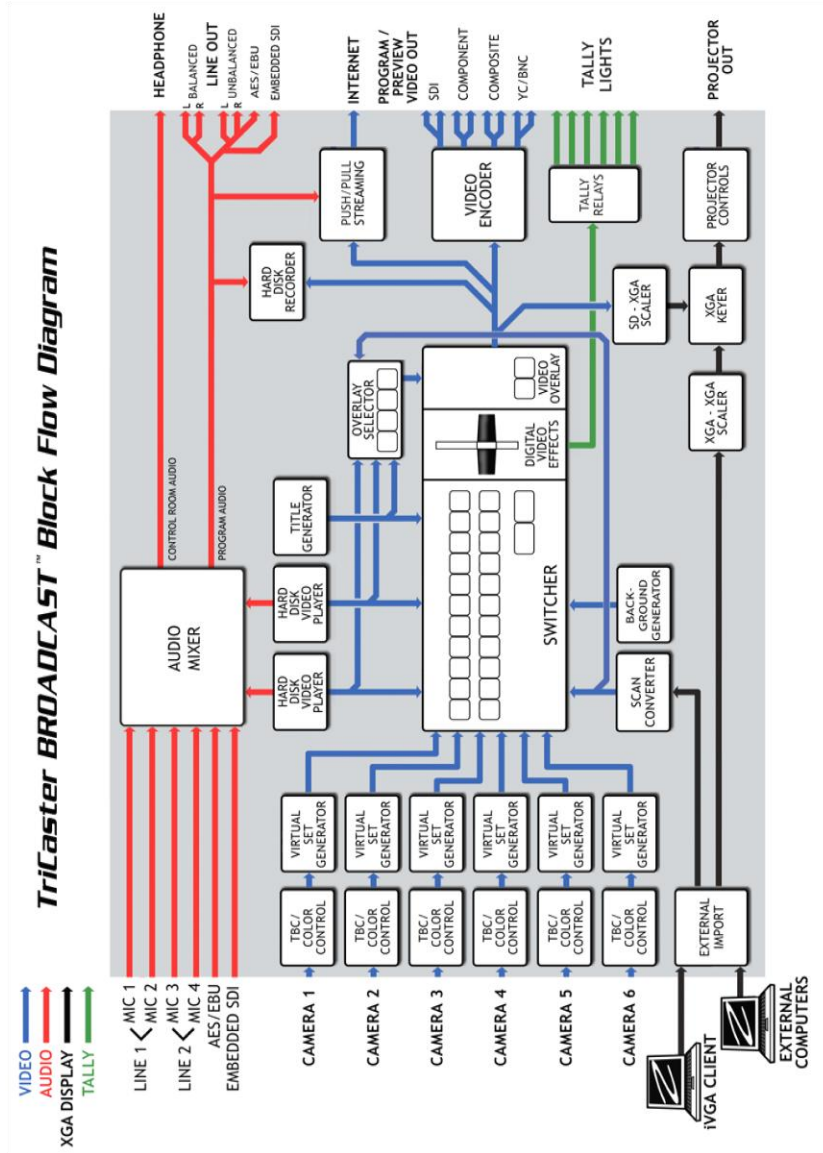

13 APPENDIX B – KEYBOARD SHORTCUTS

13.1 LIVE PRODUCTION

13.1.1 SWITCHER...

Live Row, Inputs 1 – 11 (as applicable by model)	F1 – F11
Preview Row, Inputs 1 – 11 (as applicable by model)	1 – 0 and minus key (11)
Effects Row, Inputs 1 – 11 (as applicable by model).....	Alt + 1 – 0 and minus key (11)
Fade Overlay On & Off	F
Take Overlay On & Off	D
Fade All	A
Take All	S
Network In Overlay On/Off	Esc (Escape Key)
Master Fade to Black (to BG, STUDIO/BROADCAST 6-cam mode).....	Backspace (or Ctrl + B)
Select Transition (prev/next)	, and . (un-Shifted < and > keys)
Slow... Medium... Fast	Z... X... C
Slower Speeds	Shift + Z... X... C
Faster Speeds	Alt + Z... X... C
Variable Speed (Use/Set)	V / Shift + V
Random Transition from Bin	Alt + / (the ? Key)
Reverse Transition (off/on)	E / Shift + E
Advance Transition (off/on)	R / Shift + R

Remove Current TransitionShift + Delete Key

Remove All TransitionsAlt + Delete Key

T-Bar

TakeReturn Key

Take T-Bar Back to TopShift + Return

Auto... Go/Pause.Spacebar

Auto ReverseShift + Spacebar

Adjust T-Bar... Down/UpT / Shift + T (faster add Alt)

Halfway T-Bar... Take/AutoH / Shift + H

User T-Bar Position... Take/AutoG / Shift + G

User T-Bar Position... Set/ViewAlt + g / Alt Shift + G

LiveSet - zoom In/Out LiveSet selected on Preview Page Up, Page Down

13.1.2 DDR & PICTURE

Play/StopK

Jog Backwards/ForwardsJ / L

Rewind/Fast ForwardShift + J / L

Stop/Go to StartCtrl + K

Pause (On/Off)P

Cue On/OffU

Go to Start/End.Home / End Keys

Step through ClipsUp / Down Arrows

Playlist - select to top Shift + Home

Playlist - select to bottom Shift + End

Playlist – add to selection (up) Shift + Up arrow

Playlist – add to selection down Shift + Down arrow

One Frame Back/ForwardLeft/Right Arrow... or Alt + J / L

Five Frames Back/ForwardShift + Left/Right Arrow

One Second Back/ForwardCtrl + Left/Right Arrow

Go to Time PositionCtrl + G

Loop On/Off ‘

LED Normal/Time Remaining;

LED Local/Total TimeShift + ;

Mark In/Out PointI / O

Clear In/Out PointAlt + I / O

Go to In/Out Point[and]

Adjust In Point[+ Left/Right Arrow

Adjust Out Point] + Left/Right Arrow

13.1.3 VGA OUTPUT

Take VGA OverlayEsc

Fade VGA OverlayShift + Esc

13.2 CAPTURE MEDIA

13.2.1 CAPTURE...

Record/Stop	Enter Key
Pause Toggle	Spacebar
Delete	Delete Key (when stopped)
DV Deck Control...	
Reverse Shuttle	J
Pause / Play	K
Forward Shuttle	L
Rewind	Shift + J
Stop	Shift + K
Fast Forward	Shift + L
One Frame Back	Alt + J (when paused)
One Frame Forward	Alt + L (when paused)
Go to Time Position	Ctrl + G

13.3 EDIT MEDIA

13.3.1 CAPTURE...

Record/Stop	Enter key
Pause toggle	Spacebar
Chop recording	Backspace
Reset (Clear) recording	Delete key (when recording)
Delete	Delete key (when stopped)
DV Deck Control...	
Reverse Shuttle	J
Pause / Play	K
Forward Shuttle	L
Rewind	Shift + J
Stop	Shift + K
Fast Forward	Shift + L
One Frame Back	Alt + J (when paused)
One Frame Forward	Alt + L (when paused)
Go to Time position	Ctrl + G

13.3.2 PLAY

Play/Stop	Spacebar (or K)
-----------------	-----------------

Pre-roll and Play Shift + Spacebar

Backwards/Forwards J / L

Rewind/ Fast Forward Shift + J / L

Stop/Go to start Ctrl + K

Go to Time position Ctrl + G

Go to Start/End of project. Home / End buttons

Step through clips Up / Down arrows

Step through clips and zoom (timeline) Shift + Up / Down arrows

One Frame Back Left Arrow... 1 or Alt + J

One Frame Forward Right Arrow... 2 or Alt + L

Five Frames Back Shift + Left Arrow... or 3

Five Frames Forward Shift + Right Arrow... or 4

One Second Back Ctrl + Left Arrow

One Second Forward Ctrl + Right Arrow

Adjust Offset (-/+ 1 frame) Alt + Left/Right Arrow

13.3.3 DRAG AND DROP

Clone Ctrl + drag

Inherit. Alt + drop item

Preview in and out points Alt + rollover

Storyboard Only – Drag/Drop...

Change in/out points	Alt + drag
Change in/out points... audio only	Ctrl + Alt + drag
Slip and slide	Shift + Alt + drag:
Slip and slide; audio only	Shift + Ctrl + Alt + drag
Timeline Only – Drag/Drop...	
Change in and out points	Drag Crouton edge
Stretch (speed)	Alt + drag edge
Slip and slide	Shift + Alt + drag
Change length of Transition	Drag Transition edge
Change in and out points of Transition	Shift + drag Transition edge
Slip and slide Transition.....	Shift + Alt + drag Transition
Set current time marker	Shift + Click
Pan through project	Right Click + Drag Left/Right
Zoom in/out of project	Right Click + Drag Up/Down
Slowly pan or zoom project	Ctrl + Right Click + drag

13.3.4 IN/OUT POINTS

Mark In/Out Point	I / O (or E / R)
Mark In/Out then review	Shift + I / O
Clear In/Out Point	D / F (or Alt + I / O)
Clear Both In and Out Points	G (or Alt + P)

Go to In/Out Point Q / W
Pre-roll before In/Out and play Shift + Q / W
Adjust In point Q + Left/Right Arrow
Adjust Out Point W + Left/Right Arrow

(Note: if no clips are selected... these functions use nearest clip to current time)

13.3.5 MISC

LED Normal/Time Remaining ;
LED Local/Total Time Shift + ;
Fades... Insert Range Alt + F
Toggle Overlay on and off Y

13.3.6 TIMELINE TOOLS

Cut (Razor) at edit line C
Cut to selected clip (Multicam) Z
Constrain to vertical dragging only V
Zoom and center Timeline view..... =
Add Marker M
Go to Previous/Next Marker , / . (<> keys)
Toggle Timeline Ripple T
Disable Timeline Ripple Shift + T
Fit display to current clip Enter key

Fit Whole Project BackSlash
Center display around edit line BackSpace

13.4 EDIT TEXT

13.4.1.1 FONT

Font Name (next/previous)..... F5 (Shift +)
Font Size F6 (Shift +)
Font Rotation F7 (Shift +)
Font Tracking (Spacing)..... F8 (Shift +)

13.4.1.2 TEXT

Increase/decrease Width by 5 pixels Alt w (Shift +)
Increase/decrease Height by 5 pixel Alt h (Shift +)
Increase/decrease Edge by 1 pixel Alt k (Shift +)
Increase/decrease Italic by 1 pixel Alt i (Shift +)
Increase/decrease Tracking by 1 pixel Alt space (Shift +)
Next/Previous Font Alt f (Shift +)

13.4.1.3 CLIPBOARD

Select All Ctrl a
Deselect All Ctrl d

Cut Ctrl x
Copy Ctrl c
Paste Ctrl v
Delete Delete
Redo..... Ctrl y
Undo Ctrl z

13.4.1.4 FILE

New CG Project Ctrl n
Open CG Project Ctrl o
Add Files Alt + Insert
Save CG Project Ctrl s
Save As... CG Project Ctrl Shift s
Save Current Page Ctrl Alt s
Save Current Page as Image Alt Shift s

13.4.1.5 TEXT ENTRY

Selects One character Shift + L/R Arrow
Moves curser to beginning Home
Moves curser to end End
Selects to the beginning Shift + Home

Selects to the end Shift + End
Deletes entire trailing word Ctrl + Delete
Selects entire line Shift + Up/Down Arrow
Selects One character Shift + L/R Arrow
Kerning by letter Alt + L/R Arrow
Move and scale LMB (Left Mouse Button)
Rotate and Spacing LMB + Shift
Multi-Select by area LMB + Drag
Multi-Select Individual Objects LMB + Ctrl

13.4.1.6 MODIFY TOOL

Nudge Up 1 pixel Up Arrow
Nudge Down 1 pixel Down Arrow
Nudge Left 1 pixel Left Arrow
Nudge Right 1 pixel Right Arrow

13.4.1.7 ALIGNMENT

Left Safety Alt l
Center Safety Alignment Alt c
Right Safety Alt r
Bottom Safety Alignment Alt b

13.4.1.8 LAYOUT

Align Left Alt Shift l

Align Alt Shift r

Align Top Alt Shift t

Align Bottom Alt Shift b

Align Horizontal Center Alt Shift c

Align Vertical Center Alt Shift v

13.4.1.9 PAGE

Adds a new page Ctrl Insert

Deletes Current Page Ctrl Shift Delete

Clones Current Page Ctrl Shift Insert

Moves up the Page list PageUp

Moves down the Page list PageDown

Moves to top of Page list Ctrl PageUp

Moves to bottom of Page list Ctrl PageDown

13.4.1.10 SHADOW

Add (Sub) 1 to Shadow Offset X Alt x (Shift +)

Add (Sub) 1 to Shadow Offset y Alt y (Shift +)

Shadow Type (up/down)..... Alt F5 (Shift +)

Shadow Size (raise/lower)..... Alt F6 (Shift +)

Shadow Angle (raise/lower) Alt F7 (Shift +)

Shadow Softness (raise/lower)..... Alt F8 (Shift +)

13.4.1.11 EDGE

Edge Type (up/down)..... Ctrl F5 (Shift +)

Edge Size (raise/lower) Ctrl F6 (Shift +)

13.4.1.12 VIEW

Toggles Safe Area on and off Alt s

13.5 GENERAL

13.5.1 CLIPBOARD...

Cut.Ctrl + X

CopyCtrl + C

PasteCtrl + V

UndoCtrl + Z

RedoCtrl + Y

DeleteDelete Key

13.5.2 FILES/FILEBIN...

OpenCtrl + O

SaveCtrl + S

Save AsCtrl + Shift + S

Add FilesCtrl + I

New FolderCtrl + N

File PropertiesCtrl + D

BackBackspace

ForwardShift + Backspace

Selection...

Select AllCtrl + A

Deselect AllCtrl + Shift + A

First ItemHome

Last ItemEnd

Previous ItemLeft/Up Arrow

Next ItemRight/Down Arrow

Previous Item and Keep Current SelectionCtrl + Left/Up

Next Item and Keep Current SelectionCtrl + Right/Down

First Item and Keep Current SelectionCtrl + Home

Last Item and Keep Current SelectionCtrl + End

Select All Previous ItemsShift + Home

Select All Previous and Keep Current SelectionCtrl + Shift + Home

Select All Following ItemsShift + End

Select All Following and Keep Current Selection ...Ctrl + Shift + End

3

3-Camera, 19, 20, 21, 53, 56, 57

A

Aspect Ratio, 85, 115, 153

Audio

Balance, 46, 155

Auto Chop, 121

B

Background Color, 115

Balance, 46, 155

Beat, Cut to, 163

Brightness Knob, 97

C

Camera

DV, 39, 40, 110

Mode, 19, 20, 21, 53, 56, 57, 58

Capture, 16, 39, 108, 121, 233

Capture

Chop, 121

Chop, 121

Still, 42

Chop, 121

Chroma Keying, 9, 10, 11, 12, 32, 33, 34, 35, 37, 79,

80, 81, 83, 84, 87, 95, 188, 189, 190, 191, 250

Clip

Markers, 132, 134

Clip Markers, 132, 134

Color

Non ITU-R BT601, 155

Color Correction

RGB, 158

White Balance, 156

Color Picker, 75, 81, 134, 143, 154, 173, 181

Colors

Background, 115

ColorPicker, 75, 81, 134, 143, 154, 173, 181

White Balance, 156

Contrast Knob, 97

Control Tab, 152

Crop, 48, 96, 97, 151

Cross Fade, 135

Cut, Copy, Paste, Delete, 121, 134, 173

D

DV, 39, 40, 110

E

Ease In/Out, 146, 155

Edit Line, 114, 123, 125, 128, 129, 130, 131, 133

F

Fade, 48, 139

Fields, 115, 153

File

Capture, 16, 39, 108, 121, 233
Filebin, 117, 185, 242
Columns, 118
Hotlist, 29, 33, 41, 44, 45, 111, 119, 135, 138, 140, 151
Navigation, 117
View Options, 117
Files
File Operations, 173
Navigation, 117
Undo/Redo, 45, 120, 168, 173, 239, 242

G

Gamma, 157, 158
Grid and Guides, 150, 177

H

Help, 159, 162
Hotkeys, 71, 127, 230
Hotlist, 29, 33, 41, 44, 45, 111, 119, 135, 138, 140, 151

I

Icons
Timecode, 117
IMAG, 107, 223, 224, 225
Image Super-Sampling, 154
In/Out, 125, 145, 236
Inherit, 130, 135, 235
Interlacing, 115, 153
iVGA, 25

J

Jog & Shuttle, 111, 114, 231, 233, 234

K

Keyboard Shortcuts, 71, 127, 230
Keying, 9, 10, 11, 12, 32, 33, 34, 35, 37, 79, 80, 81, 83, 84, 87, 95, 188, 189, 190, 191, 250

L

Latency, 223, 224, 225
LiveMatte, 9, 10, 11, 12, 32, 33, 34, 35, 37, 79, 80, 81, 83, 84, 87, 188, 189, 190, 191, 250
LiveSet, 8, 11, 14, 26, 37, 50, 80, 81, 83, 85, 87, 92, 98, 166, 169, 170, 188, 189, 191, 192, 194, 195, 197, 231, 250
Loop, 114
Luma Keying, 9, 10, 11, 12, 32, 33, 34, 35, 37, 79, 80, 81, 83, 84, 87, 188, 189, 190, 191, 250

M

Markers, 132, 134
Monitoring
Mode, 19, 20, 21, 53, 56, 57, 58

N

Network
Connecting, 25, 211, 214
iVGA, 25
Ping, 215
Streaming, 16, 39, 97, 99, 204, 205, 206, 208, 209, 212
Testing, 214
Non ITU-R BT601 color, 155

O

Output
Brightness and Contrast, 97
Overlay, 48, 85, 114, 120, 122, 128

P

Pause, 28, 42, 56, 69, 70, 71, 127, 231, 233, 234
Ping, 215
Play
 Reverse, 71, 117, 127
Play, Pause, & Stop, 28, 42, 56, 69, 70, 71, 127, 231,
 233, 234
Project Marker, 132, 133, 134

R

Resolution, 121, 122, 153, 190, 250
Restore, 78, 200
Ripple, 120, 126

S

S/S, 125
Scrolling, 130
Set In/Out, 125, 145, 236
Shadows, 143, 144, 181, 182, 241, 242
Shear, 149
Shortcuts, 71, 127, 230
Shuttle, 111, 114, 233, 234
Size, 68
Slip and Slide, 125
Snapping, 131
Still, 42
Stop, 28, 42, 56, 69, 70, 71, 127, 231, 233, 234
Storyboard, 43, 44, 45, 114, 118, 119, 120, 123, 124,
 125, 126, 127, 129, 130, 131, 235
 Ripple, 126
Streaming, 16, 39, 97, 99, 204, 205, 206, 208, 209,
 212
 Flash, 10, 97, 99, 100, 205, 210, 213
Super-Sampling, 154

T

Templates, 72, 169
Thumbnail
 Timecode, 117
Time Bar
 Zooming and Scrolling, 130
Timeline
 Copying Clips, 134
 Ripple, 120, 237
 Snapping, 131
 Zooming and Scrolling, 130
Titling, 72
 Grid and Guides, 150, 177
 Lock Aspect Ratio, 179
 Templates, 72, 169
Tool Shed, 49, 114, 116, 126, 136, 137, 159, 160, 161,
 164
Tracks
 Enlarging, 131
Transition, 31, 60, 61, 62, 63, 64, 124, 126, 127, 136,
 137, 230, 231, 236
 Reverse, 63
Transitions
 Inherit, 130, 135, 235
Transitions, Transitions
 Adjusting, 136

U

User Presets, 160, 161

V

Video
 Aspect, 85, 115, 153
 Crop, 48, 96, 97, 151
 Fade, 48, 139
 Fields, 115, 153
 Flash, 10, 97, 99, 100, 205, 210, 213

HD, 121, 122, 153, 190, 250
Image Super-Sampling, 154
Interlaced, 115, 153
Quality, 154
Shadows, 143, 144, 181, 182, 241, 242
Size, 68
Streaming, 16, 39, 97, 99, 204, 205, 206, 208, 209,
212
Virtual set, 8, 10, 11, 14, 26, 37, 50, 80, 81, 83, 85,
87, 92, 98, 166, 169, 170, 188, 189, 191, 192, 194,
195, 197, 231, 250

W

Waveform/Vectorscope, 21, 57, 58, 78
White Balance, 156
Windows
Color Picker, 75, 81, 134, 143, 154, 173, 181

Z

Zooming, 130

Software Engineering: Andrew Cross, Mike Watkins, James Killian, Jeremy Wiseman, Kirk Morger, Masaaki Konno, Kevin Nations, John Perkins, Abheeshta Seethepalli, Nathan Kovner, Brian Brice, Kenneth Long, Steve Bowie, Michael Story

Hardware Engineering: Kevin Rouviere, Charles Steinkuehler, Dale Whitt, Menghua Wang

Marketing: Michael Kornet, Philip Nelson, Donetta Colboch, Paul Lara, Michael "Aussie" Holton, Andrew Yaple, Phil Cassell

Content: Rex Olson, Jarrod Davis, Graham Toms, Gil Triana

Additional Thanks: NewTek Technical Support, NewTek Customer Service, NewTek Sales

This product uses the FreeImage library. This is licensed under the LGPL license (see link below).

For the source, and the ability to change and recompile this component, please visit :

<http://freeimage.sourceforge.net/>

This product uses the LAME library. This is licensed under the LGPL license (see link below).

For the source, and the ability to change and recompile this component, please visit : <http://lame.sourceforge.net/>

This product uses the FAAC library. This is licensed under the LGPL license (see link below).

For the source, and the ability to change and recompile this component, please visit : <http://www.audiocoding.com/>

This product uses the FFmpeg library. This is licensed under the LGPL license (see link below).

For the source, and the ability to change and recompile this component, please visit : <http://www.ffmpeg.org/>

For a copy of the LGPL licence, please visit : <http://www.gnu.org/licenses/lgpl.html>

Portions use Microsoft Windows Media Technologies. Copyright (c)1999-2008 Microsoft Corporation. All Rights reserved.

VST PlugIn Spec. by Steinberg Media Technologies GmbH.

Copyright 2008 NewTek Inc., 5131 Beckwith Blvd. San Antonio, TX USA 78249. SpeedEDIT, LiveSet, LiveMatte, MultiShot and LiveText are trademarks of NewTek. All other brand names, product names, or trademarks belong to their respective holders. HDV is a trademark of Sony Corporation and Victor Company of Japan, Limited (JVC)